

BLOOM™ WINCH



Series 1200 Galv & Series 1200C Galv

HYDRAULIC CABLE WINCHES

The rugged construction and versatility of the **Series 1200 Galv** and **Series 1200C Galv** make it adaptable to a wide range of applications. **Series 1200 Galv** direct drive winches are used for industrial pulling and hoisting applications, fishing boats, marine craft, drill rigs, small cranes, factory material handling and rear load waste handlers. **Series 1200C Galv** winches are equipped with a sliding clutch to allow free-spooling of the drum for pulling and dragging applications including factory material handling, mining and logging equipment, flat bed trailers, air freight pullers, off the road tractors and rear of cab and front mounting on ½ to 1½ ton trucks. Both **Series 1200 Galv** and **Series 1200C Galv** are available with a oil cooled adjustable automatic safety brake in a variety of motor displacements.

*"Quality Since
1910"*

1200 Galv Series
shown with oil cooled
safety brake Low
Profile or Base Mount
Available

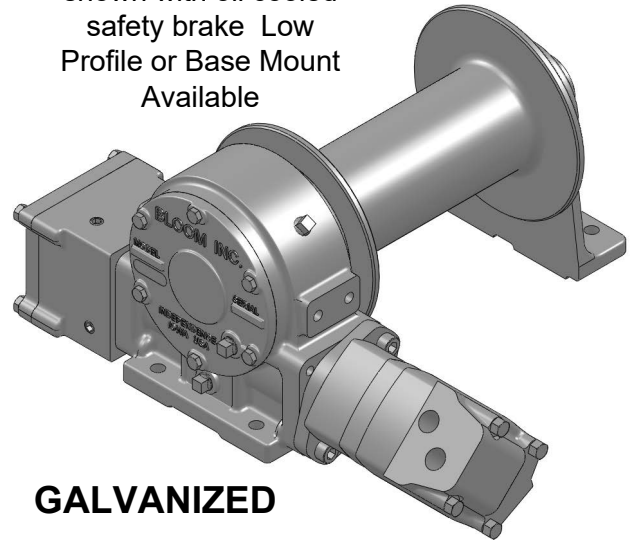

GALVANIZED

**UP TO 12,000 POUNDS
CAPACITY**

Bloom™ Hydraulic Cable Winches – Standard Features

- | | |
|----------------------|---------------------------------------------------------------------------------------------------------------------------------------------------------|
| GEAR CASE | - Made of high strength cast iron. Completely sealed for oil enclosed operation and to keep dirt out. |
| WORM SHAFT | - One piece alloy steel hardened and ground for extra durability. |
| WORM GEAR | - High tensile aluminum-nickel alloy bronze. Optimum lead and pressure angles transmit maximum power to the drum. |
| GEAR RATIO | - 20:1 standard, 27:1 and 40:1 optional ratios provide optimum efficiency in power and speed. |
| BEARINGS | - Worm gear and worm shaft run on tapered roller bearings. Outer end housing has a sealed ball bearing. |
| DRUM SHAFT | - 1-1/2" diameter heat -treated alloy steel minimum tensile strength 150,000 psi. |
| CABLE DRUM | - Tough all steel construction resists breakage or warping. |
| CLUTCH OPTION | - Series 1200C Galv winches comes equipped with heat-treated dog type clutch to provide free-spooling of the winch drum. Positive lock-in and lock-out. |
| BRAKE OPTION | - Oil cooled automatic safety brake disengages when a load is lifted and automatically engages when power is removed or the load is lowered. |



www.bloommfg.com

BLOOM
Manufacturing LLC
Winch Division

*Lifting
Pulling
Hoisting*

Toll Free Number: 1-800-394-1139

"Custom Engineered Solutions"
1443 220th Street, Independence, Iowa 50644 • FAX: 319-827-1140 • PHONE: 319-827-1139

BLOOM™ WINCH

Series 1200 Galv & Series 1200C Galv Model Selection from Performance Data



Quality Since
1910™

MODEL EXAMPLE: 12-B-4.9-L8-C-RH-20-LP-GALV

Gear Case and Shaft Designation

12 = Series 1200 Galv or Series 1200C Galv with 1-1/2"

Drum Shaft

Oil Cooled

Automatic

Safety Brake

Hydraulic Motor Designation

A, B, C, DD, E, G, 4.9, 6.2, 8.0, 9.6, 11.9

N - No Motor

IS - Input Shaft

Drum Sizes

S8, L8, XL10, XL12, XL14

Galvanized

Low Profile Mounting
(specify with or without
mounting angles)

Gear Ratio

20:1, 27:1, 40:1

Hydraulic Motor Position
(R.H. or L.H.)

Clutch Designation
(1200C Series)

DRUM CAPACITY

CABLE DIAMETER (IN.)	1/4	5/16	3/8	7/16	1/2
DRUM "S8" CAPACITY (FT.)	260	160	105	75	55
DRUM "L8" CAPACITY (FT.)	390	240	160	110	80
DRUM "XL10" CAPACITY (FT.)	840	550	340	250	170
DRUM "XL12" CAPACITY (FT.)	1320	840	580	380	280
DRUM "XL14" CAPACITY (FT.)	1900	1180	760	540	410

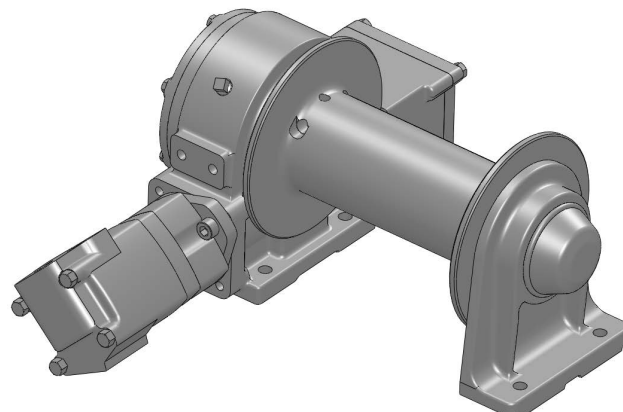

BLOOM™ WINCH



Series 1200 Galv & Series 1200C Galv

"Quality Since 1910"

Bloom Hydraulic Cable Winches With Oil Cooled Automatic Safety Brake Model Selection from Performance Data

20:1 RATIO (standard)

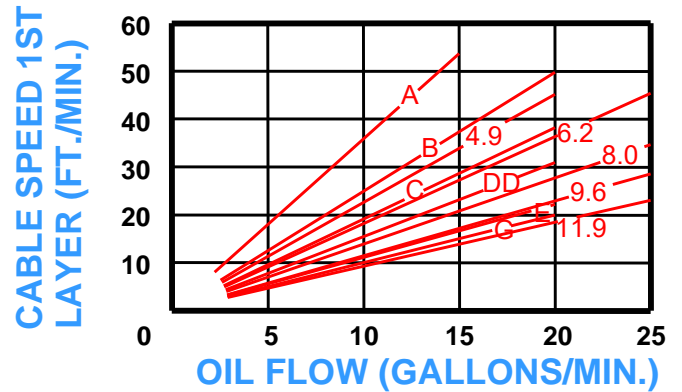
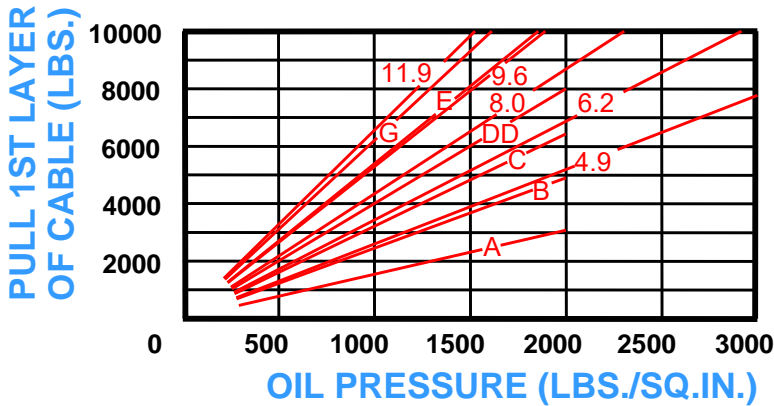

27:1 RATIO (optional)

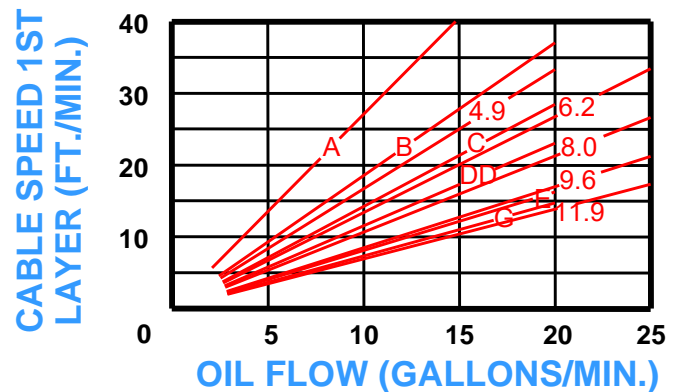
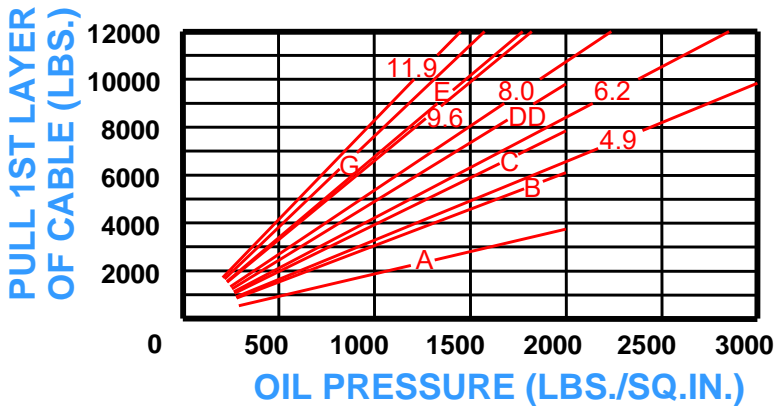

40:1 RATIO (optional)

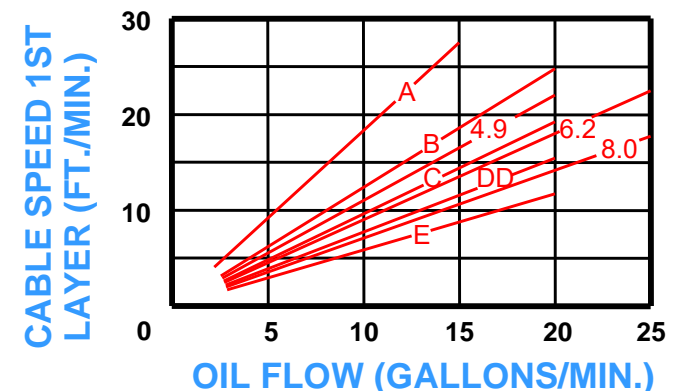
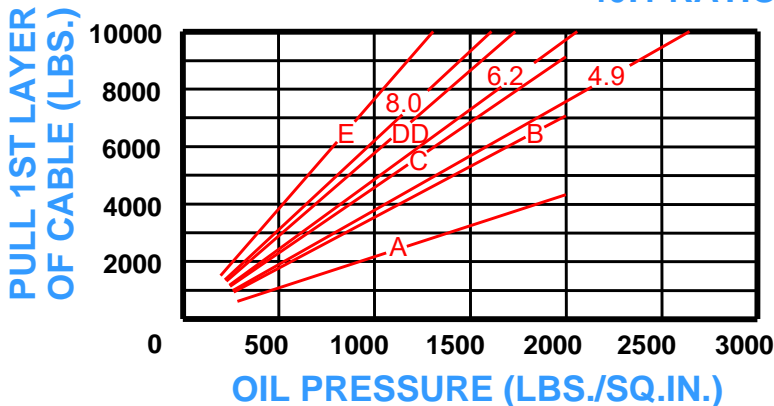



BLOOM™ WINCH

Dimensional Drawings

“Quality Since
1910”

Series 1200 Galv & Sries 1200C Galv With S8 and L8 Drum
Base Mount Model - Clutch and Direct Drive

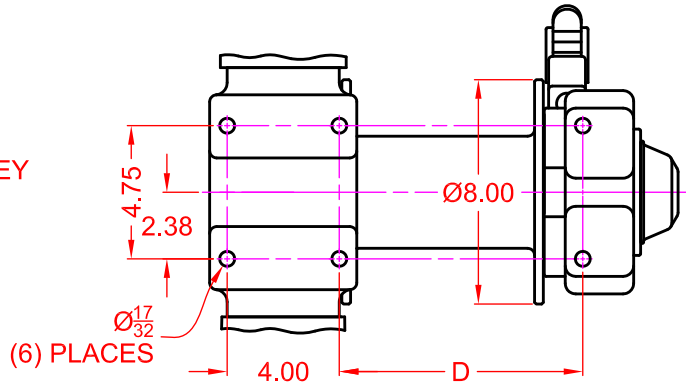
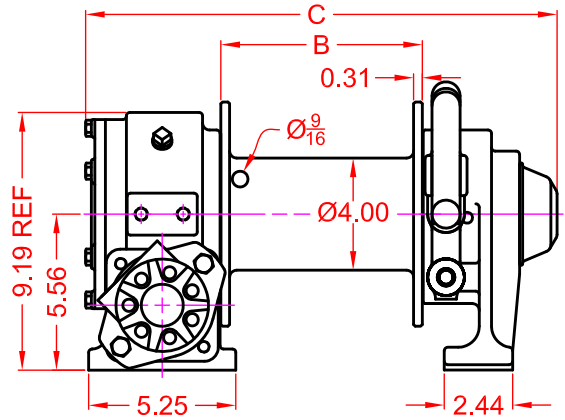
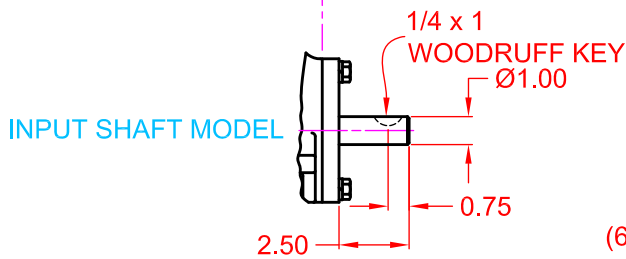
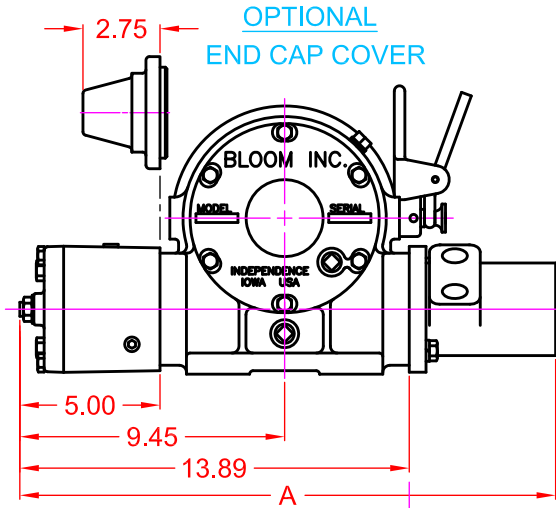

SERIES 1200C GALV BASE MOUNT, CLUTCH DRIVE

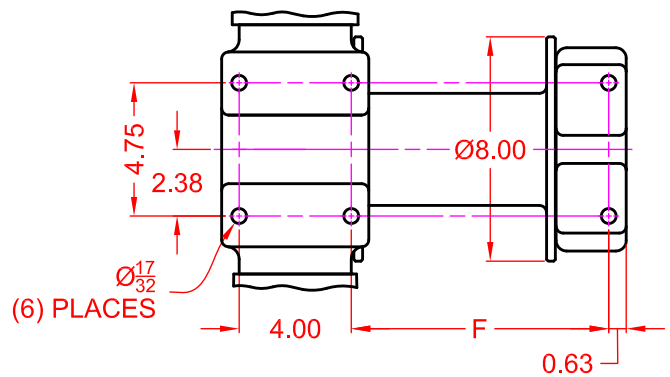
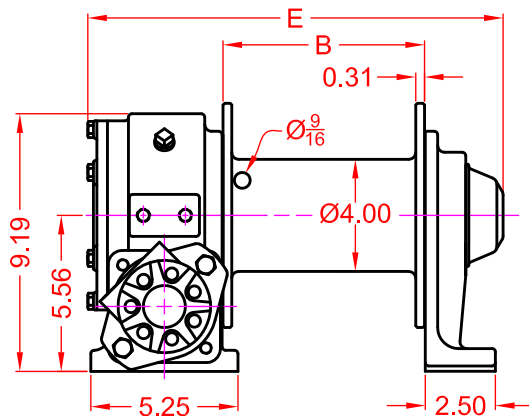

SERIES 1200 GALV BASE MOUNT, DIRECT DRIVE

MOTOR DESIGNATION	A	B	C	DD	E	G	4.9	6.2	8.0	9.6	11.9
Ⓐ DIMENSION	19.11	19.26	19.38	19.51	19.73	19.86	21.15	21.33	21.58	21.58	21.85

DRUM DESIGNATION	WINCH DIMENSION				
	Ⓑ	Ⓒ	Ⓓ	Ⓔ	Ⓕ
S8	7.19	16.82	8.68	14.82	9.18
L8	10.19	19.82	11.68	17.82	12.18



BLOOM™ WINCH

Dimensional Drawings

“Quality Since
1910”

Series 1200 Galv & Series 1200C Galv With XL10, XL12 and XL14 Drum
Base Mount Model – Clutch and Direct Drive

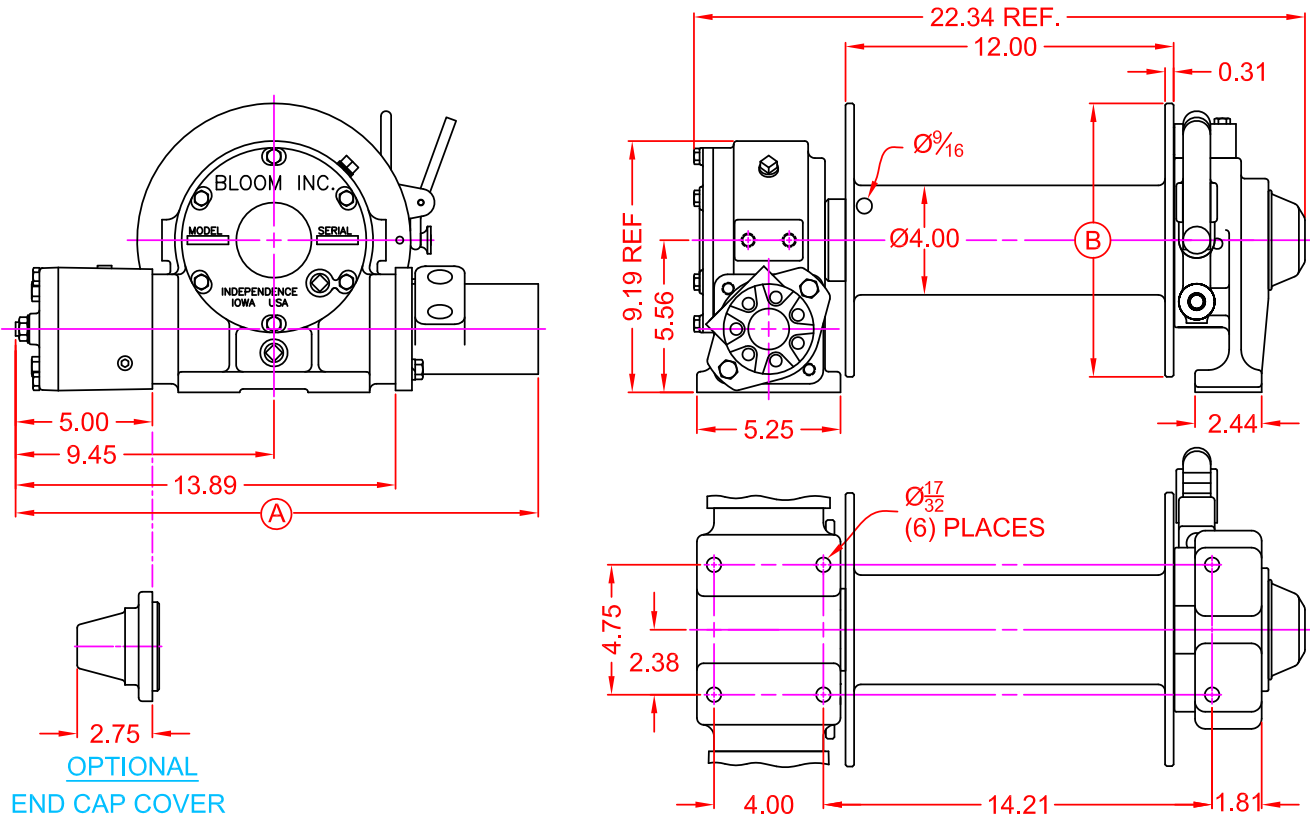

SERIES 1200C GALV BASE MOUNT, CLUTCH DRIVE

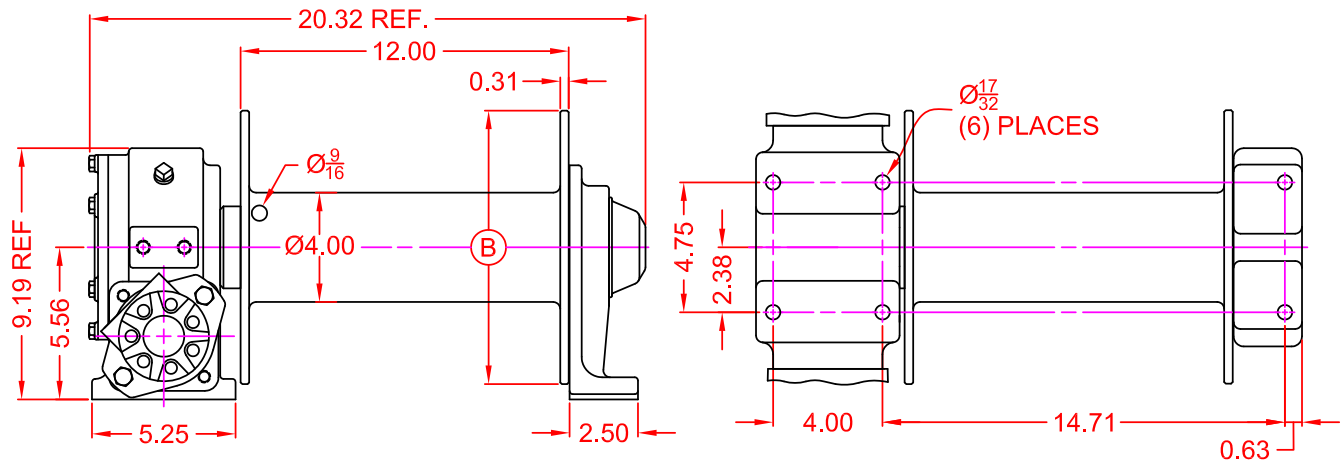

SERIES 1200 GALV BASE MOUNT, DIRECT DRIVE

MOTOR DESIGNATION	A	B	C	DD	E	G	4.9	6.2	8.0	9.6	11.9
(A) DIMENSION	19.11	19.26	19.38	19.51	19.73	19.86	21.15	21.33	21.58	21.58	21.85

MOTOR DESIGNATION	XL10			XL12			XL14		
(B) DIMENSION	10			12			14		

BLOOM™ WINCH

Correct choice of Directional Control Valves for Bloom Winches

Tandem Center Spool Valve – Work Ports are **blocked** in neutral position

Use on all winches that use motor only to hold load.

*Winches require ridged mounting plate.
See owner's manual for information about proper mounting plate thickness or call Bloom Sales Engineer at factory

WARNING!

Goods are not intended for use in the moving or lifting of persons!

The winches described herein are neither designed nor intended for use or application to equipment used in the lifting or moving of persons and it is understood that all such use shall be at the sole risk of the user.

The cable clamps on winches are not designed to hold rated loads. A minimum of 5 wraps of cable must be left on drum barrel to guarantee holding of rated load.

Applications of winch where life would be endangered by any event are not recommended.

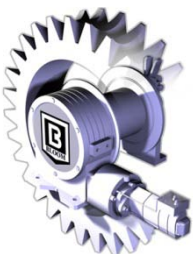

BLOOM Manufacturing LLC

Winch Division

1443 220th Street,, Independence, Iowa 50644

FAX 319-827-1140 PHONE 319-827-1139

www.bloommfg.com

©Copyright 2020 Bloom Mfg. LLC