

BLOOM™ WINCH



"Quality Since
1910"

Series 1000HC Galv

HYDRAULIC CABLE WINCHES

GALVANIZED

The rugged construction and versatility of **series 1000HC** makes it adaptable to a wide range of applications. **Series 1000HC Galv** winches are equipped with a sliding clutch to allow free-spooling of the drum for industrial pulling and dragging applications including rear of cab and front mounting on ½ to 1 ½ ton trucks, flat bed trailers, material handling, mining and logging operations, air freight pullers, off road tractors, aboard ships and boats.

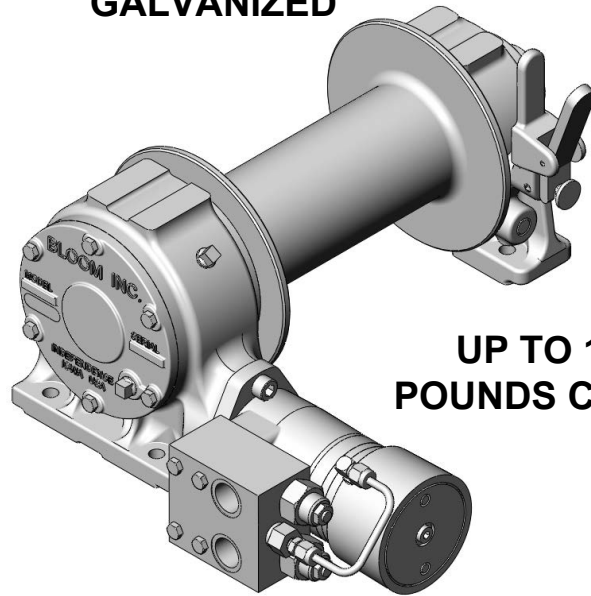

UP TO 12,000
POUNDS CAPACITY

Bloom™ Hydraulic Cable Winches – Standard Features

- MOTOR-BRAKE** - **DUET-SAFE® Double Action Braking System** combines a powerful spring applied, hydraulic released motor-brake with a double counter balance brake valve to automatically hold loads when hydraulic pressure is released and control speed during lowering operations. Winch is ideal for high speed pulling applications or wherever load holding is critical.
- GEAR CASE** - Made of high strength cast iron. Completely sealed for oil enclosed operation and to keep dirt out.
- WORM SHAFT** - One piece alloy steel hardened and ground for extra durability. Compact design allows hydraulic motor to be coupled directly to worm.
- WORM GEAR** - High tensile aluminum-nickel alloy bronze. Optimum lead and pressure angles transmit maximum power to the drum.
- GEAR RATIO** - 20:1 standard, 10:1, 27:1, 40:1 optional ratios provide optimum efficiency in power and speed.
- BEARINGS** - Worm gear and worm shaft run on tapered roller bearings. Outer end housing has sealed ball bearing.
- DRUM SHAFT** - 1-1/2" diameter heat -treated alloy steel minimum tensile strength 150,000 psi.
- CABLE DRUM** - Tough all steel construction resists breakage or warping.
- CLUTCH** - Series 1000HC Galv winches comes equipped with heat-treated dog type clutch to provide free-spooling of the winch drum. Positive lock-in and lock-out.



www.bloommfg.com

BLOOM

Manufacturing LLC

Winch Division

Lifting
Pulling
Hoisting

Toll Free Number: 1-800-394-1139

"Custom Engineered Solutions"

1443 220th Street,, Independence, Iowa 50644 • FAX: 319-827-1140 • PHONE: 319-827-1139

RV7/2020

BLOOM™ WINCH



"Quality Since 1910"

Series 1000HC Galv

Model Selection from Performance Data

MODEL EXAMPLE: 10H-3.0T-L8-C-10-LP-GALV

Gear Case Mounting

10H = Series 1000HC Galv With 1-1/2" Drum Shaft

Hydraulic Motor Designation

3.0T, 4.0T, 6.2T, 9.6T

Drum Sizes

S8, L8, XL10, XL12, XL14

Galvanized

Low Profile Mounting
(specify with or without
mounting angles)

Gear Ratio

10:1, 20:1, 27:1, 40:1

Clutch

Designation

(Do not use clutch model for
lifting Applications)

DRUM CAPACITY

CABLE DIAMETER (IN.)	1/4	5/16	3/8	7/16	1/2
DRUM "S8" CAPACITY (FT.)	260	160	105	75	55
DRUM "L8" CAPACITY (FT.)	390	240	160	110	80
DRUM "XL10" CAPACITY (FT.)	840	550	340	250	170
DRUM "XL12" CAPACITY (FT.)	1320	840	580	380	280
DRUM "XL14" CAPACITY (FT.)	1900	1180	760	540	410

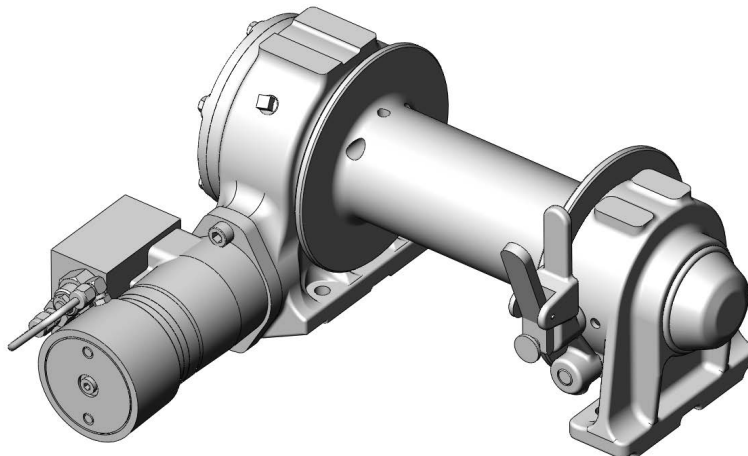

BLOOM™ WINCH



Series 1000HC Galv

Model Selection from Performance Data

“Quality Since 1910”

10:1 RATIO (optional)

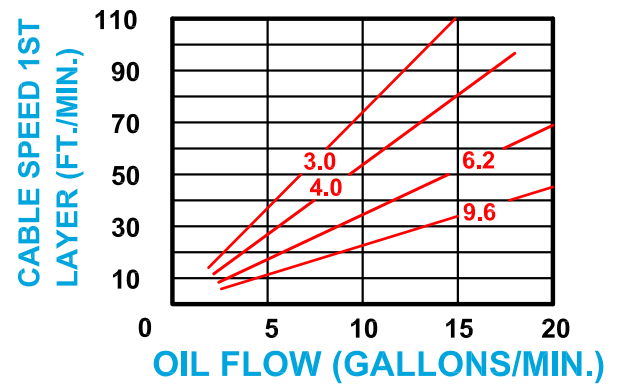
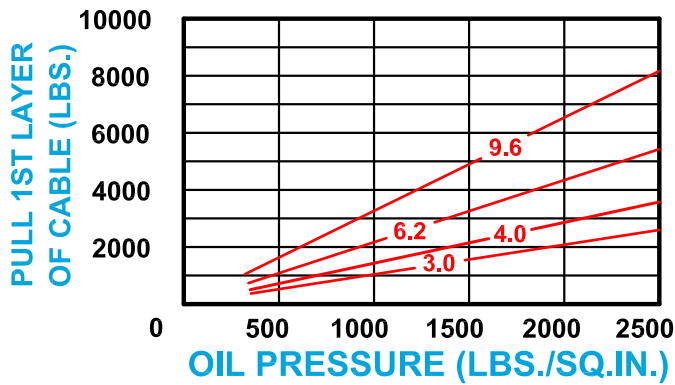

20:1 RATIO (standard)

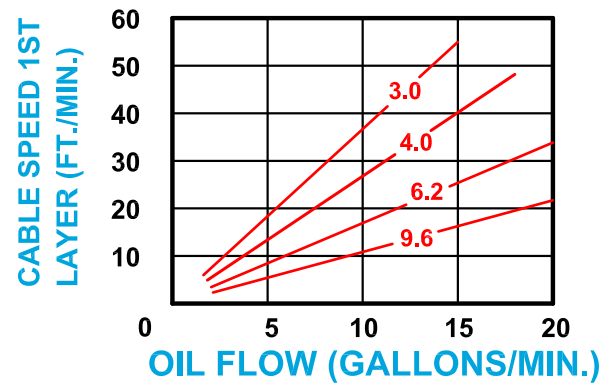
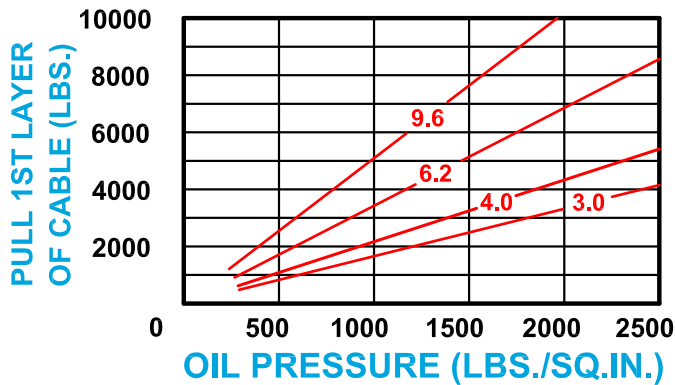

27:1 RATIO (optional)

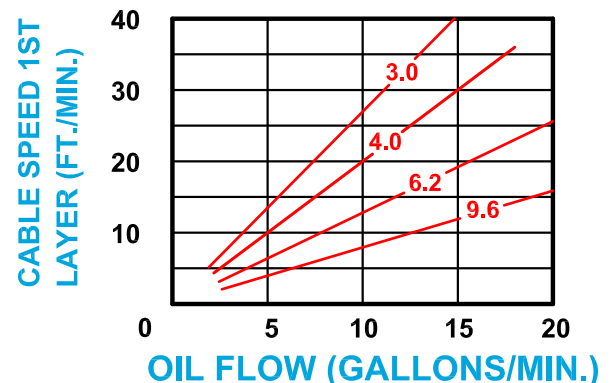
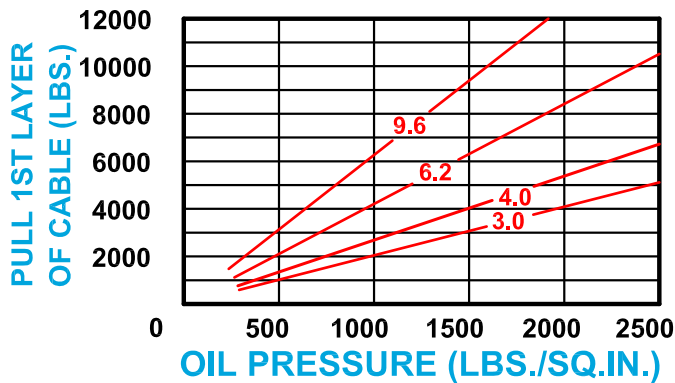

40:1 RATIO (optional)

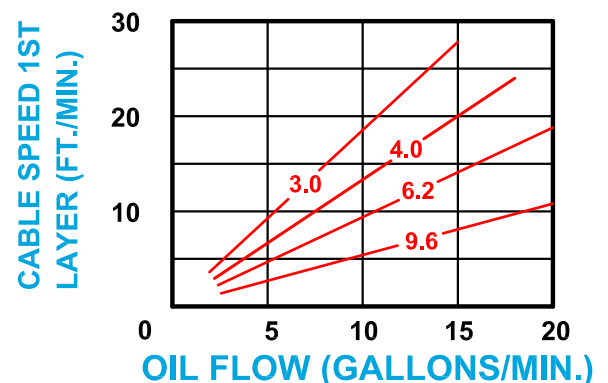
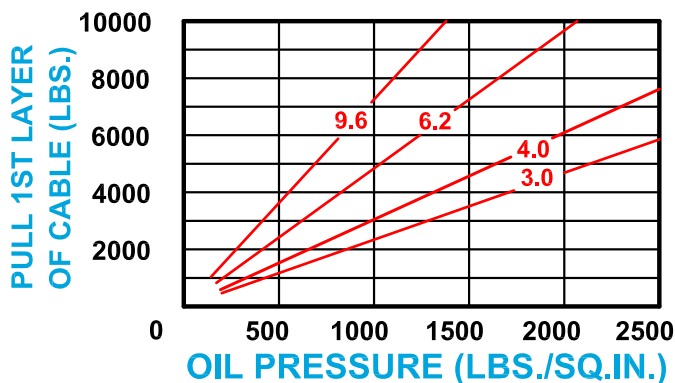



“Quality Since
1910”

BLOOM™ WINCH

Dimensional Drawings

Series 1000HC Galv K JH 'S8 and L8
Drum Base Mount Model - Clutch Drive

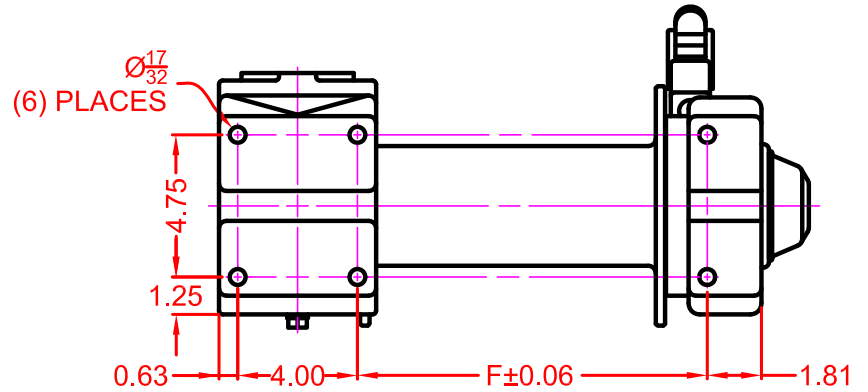
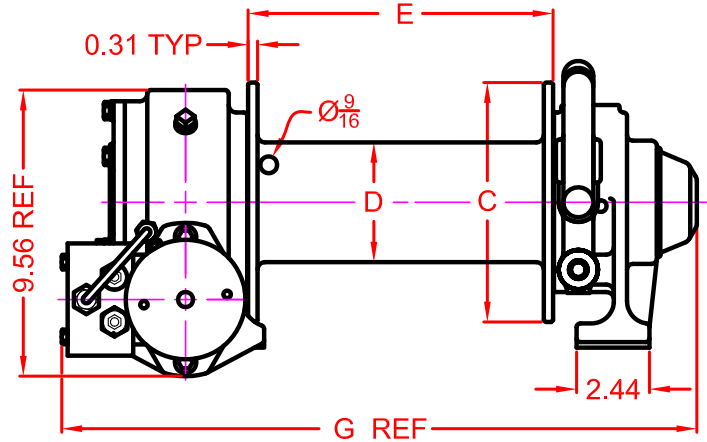
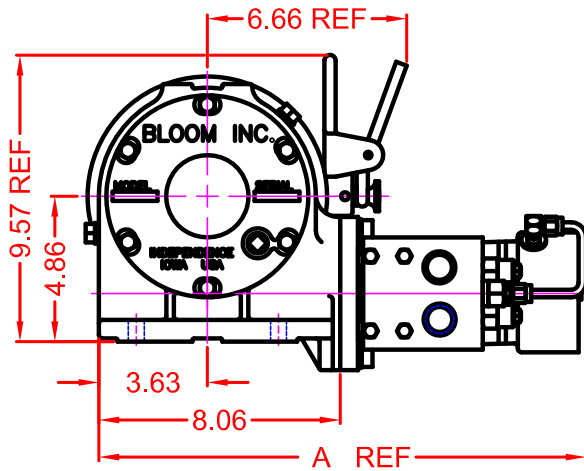

MOTOR DESIGNATION	3.0	4.0	6.2	9.6
Ⓐ DIMENSION	15.91	16.03	16.28	16.53

DRUM DESIGNATION	WINCH DIMENSION				
	C	D	E	F	G
S8	8	4	7.19	8.69	18.22
L8	8	4	10.19	11.69	21.22



"Quality Since 1910"

BLOOM™ WINCH

Dimensional Drawings

Series 1000HC Galv K JH XL10, XL12 and XL14
Drum Base Mount Model - Clutch Drive

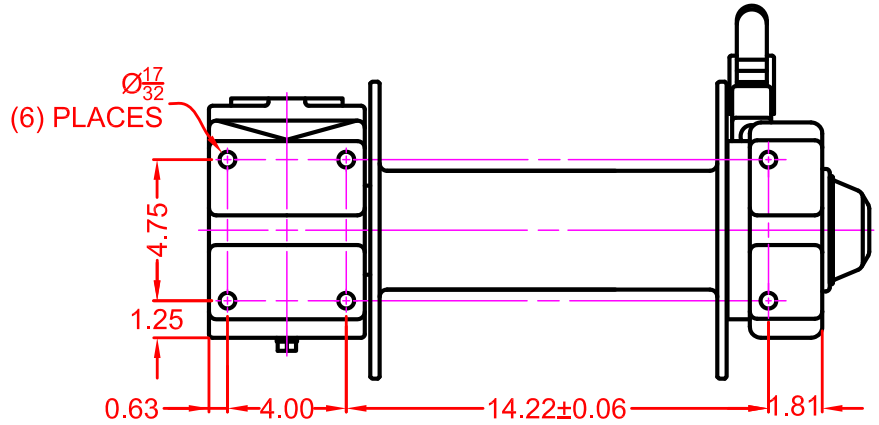
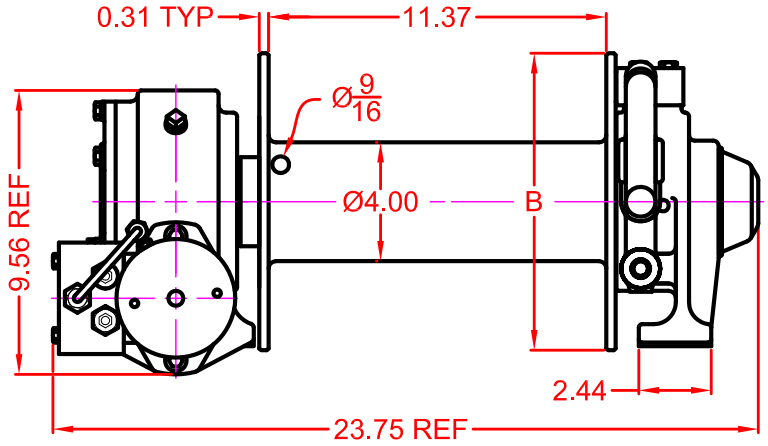
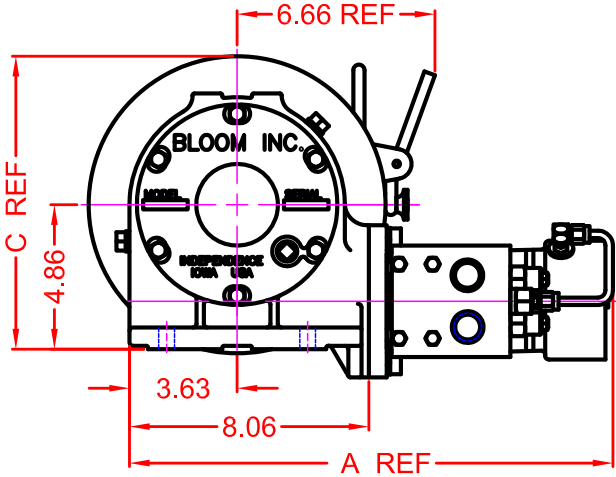

MOTOR DESIGNATION	3.0	4.0	6.2	9.6
(A) DIMENSION	15.91	16.03	16.28	16.53

DRUM DESIGNATION	XL10	XL12	XL14
B DIMENSION	10	12	14
C DIMENSION	9.86	10.86	11.86

BLOOM™ WINCH

Correct choice of Directional Control Valves for Bloom Winches

Winches require a **Motor Spool Control Valve**.
That is the valve's work ports are **open** to tank in neutral position.

*Winches require ridged mounting plate.
See owner's manual for information about proper mounting
plate thickness or call Bloom Sales Engineer at factory.

WARNING!

Goods are not intended for use in the moving or lifting of
persons!

The winches described herein are neither designed nor intended
for use or application to equipment used in the lifting or moving of
persons and it is understood that all such use shall be at the sole
risk of the user.

The cable clamps on winches are not designed to hold rated
loads. A minimum of 5 wraps of cable must be left on drum barrel
to guarantee holding of rated load.

Applications of winch where life would be endangered by any
event are not recommended.



BLOOM Manufacturing LLC

Winch Division

1443 220th Street,, Independence, Iowa 50644

FAX 319-827-1140 PHONE 319-827-1139

www.bloommfg.com

©Copyright 2020 Bloom Mfg. LLC