

BLOOM™ WINCH

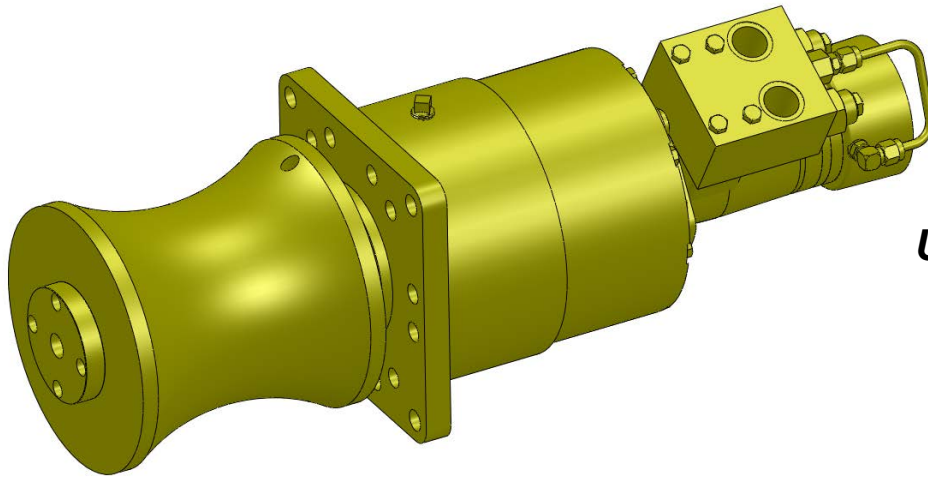

"Quality Since
1910"

Series 2000H Low Profile Hydraulic Capstan Winches



**Fast Dependable
Bloom Winches**

**Up to 4,000 Pounds
A Pull Above
the Rest**

MODEL 20H-3.0T-SR-CAP-17-6148

Bloom™ Hydraulic Capstan Winches – Standard Features

- MOTOR-BRAKE** - **DUET-SAFE® Double Action Braking System** combines a powerful spring applied, hydraulic released motor-brake with a double counter balance brake valve to automatically hold loads when hydraulic pressure is released and control speed during lowering operations. Capstan is ideal for high speed lifting and pulling applications or wherever load holding is critical.
- GEAR CASE** - Made of high strength steel. Completely sealed for oil enclosed operation and to keep dirt out.
- PLANETARY GEAR** - High Efficiency Double Reduction – Rugged – Built to Last.
- GEAR RATIO** - 17:1 Standard.
- BEARINGS** - Shaft is supported by two heavy duty oil lubricated bearings in gear case.
- OUTPUT SHAFT** - 2-1/4" diameter heat -treated alloy steel minimum tensile strength 150,000 psi.
- CAPSTAN** - Cast aluminum - keyed to shaft.



www.bloommfg.com

BLOOM

Manufacturing Inc.

Winch Division

"Custom Engineered Solutions"

**Lifting
Pulling
Hoisting**

Toll Free Number: 1-800-394-1139

1443 220th Street,, Independence, Iowa 50644 • FAX: 319-827-1140 • PHONE: 319-827-1139

BLOOM™ WINCH

Dimensional Drawings

Series 2000H Capstan



"Quality Since 1910"

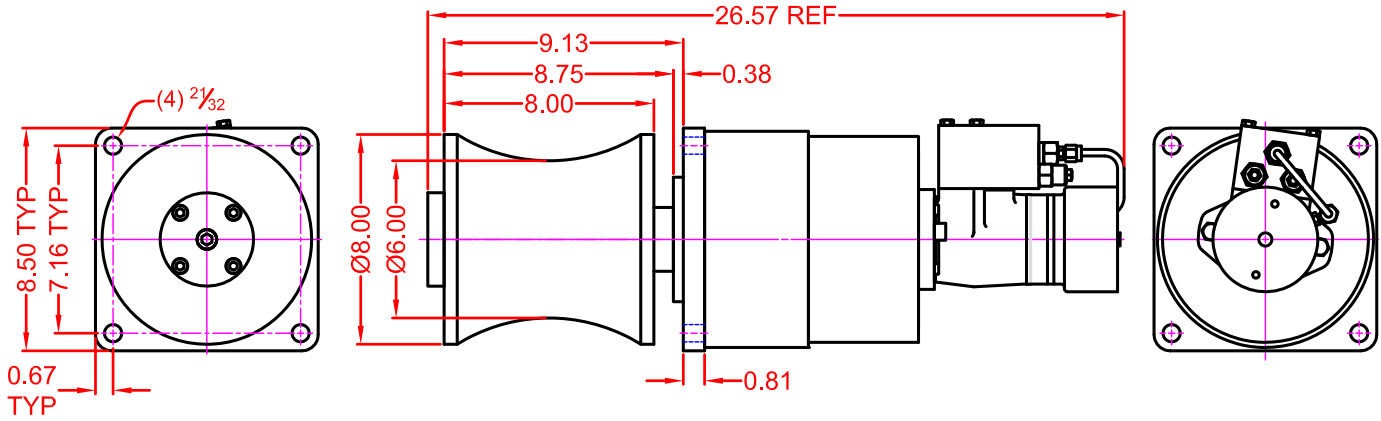

17:1 RATIO

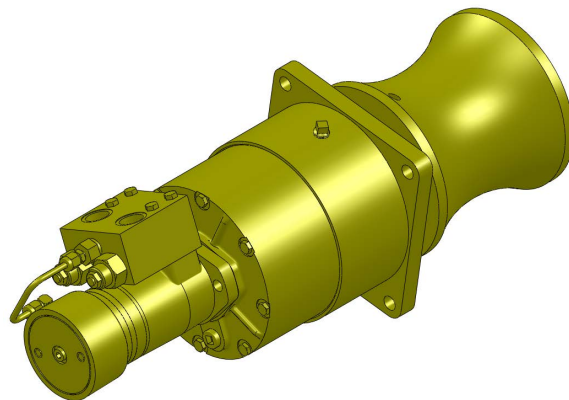
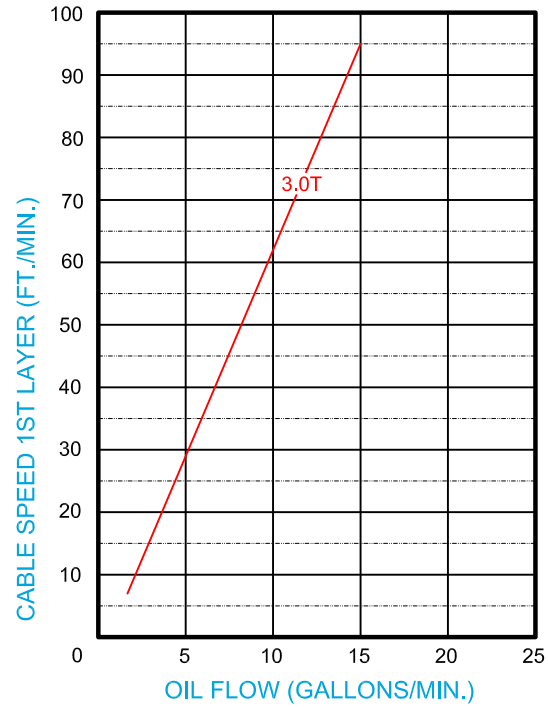
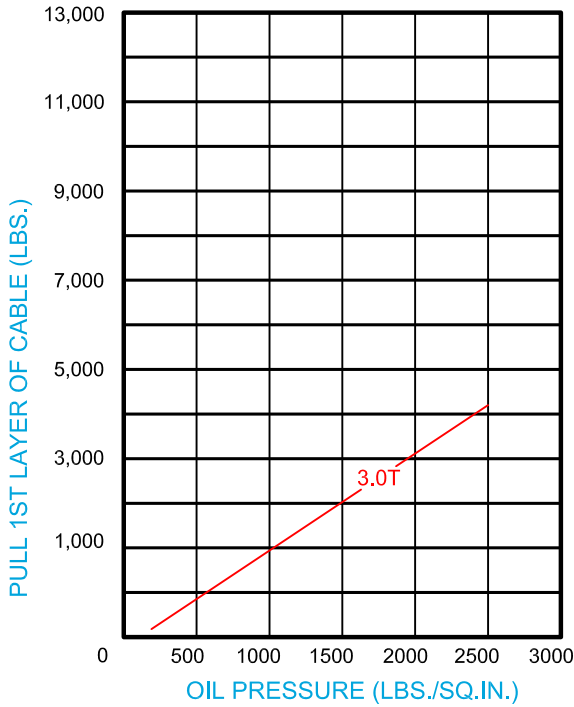

BLOOM™ WINCH

Correct choice of Directional Control Valves for Bloom Winches

Motor Spool Valve – Work Ports are **open** to tank in neutral position.
Use on all winches that use Counter Balance Valves to hold load.

*Capstans require ridged mounting plate.
See owner's manual for information about proper mounting plate thickness or call Bloom Sales Engineer at factory

WARNING!

Goods are not intended for use in the moving or lifting of persons!

The winches described herein are neither designed nor intended for use or application to equipment used in the lifting or moving of persons and it is understood that all such use shall be at the sole risk of the user.

The cable clamps on winches are not designed to hold rated loads. A minimum of 5 wraps of cable must be left on drum barrel to guarantee holding of rated load.

Applications of winch where life would be endangered by any event are not recommended.



BLOOM Manufacturing Inc. **Winch Division**

1443 220th Street,, Independence, Iowa 50644

FAX 319-827-1140 PHONE 319-827-1139

www.bloommfg.com