

BLOOM™ WINCH



Series 1000H

Hydraulic Speed Reducer

*"Quality Since
1910"*

The rugged construction and versatility of the **Series 1000H Speed Reducer** is ideal for stationary and mobile applications where slow speed, high torque, or variable speed and reversing are needed. Applications include paving and curb forming, ditching, irrigation, and plastic and extruding equipment.

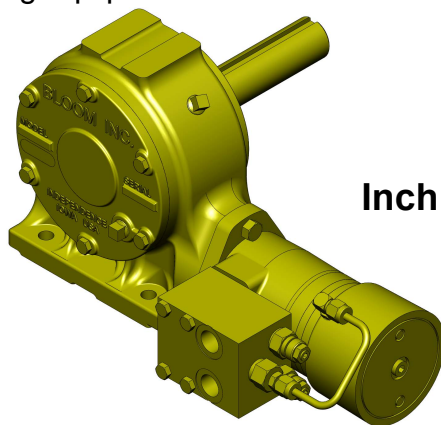

**Up To 24,000
Inch Pounds of Output Torque**

Bloom™ Hydraulic Speed Reducers – Standard Features

- MOTOR-BRAKE** - **DUET-SAFE® Double Action Braking System** combines a powerful spring applied, hydraulic released motor-brake with a double counter balance brake valve to automatically hold loads when hydraulic pressure is released and control speed during lowering operations. Speed Reducer is ideal for high speed lifting and pulling applications or wherever load holding is critical.
- GEAR CASE** - Made of high strength cast iron. Completely sealed for oil enclosed operation and to keep dirt out.
- WORM SHAFT** - One piece alloy steel hardened and ground to insure long service. The hydraulic motor couples direct to the shaft.
- WORM GEAR** - High tensile aluminum-nickel alloy bronze . Optimum lead and pressure angles transmit maximum power to the drum.
- GEAR RATIO** - 20:1 standard, optional 10:1, 27:1 and 40:1 ratios provide optimum efficiency in power and speed.
- BEARINGS** - Worm gear and worm shaft run on tapered roller bearings in an oil enclosed gear case.
- OUTPUT SHAFT** - 1-1/2" diameter heat -treated alloy steel minimum tensile strength 150,000 psi.
- MOTOR MOUNT** - SAE (A) 2 bolt flange.



BLOOM

Manufacturing Inc.

Winch Division

*Lifting
Pulling
Hoisting*

Toll Free Number: 1-800-394-1139

www.bloommfg.com

"Custom Engineered Solutions"

1443 220th Street,, Independence, Iowa 50644 • FAX: 319-827-1140 • PHONE: 319-827-1139

BLOOM™ WINCH



Series 1000H

Model Selection from Performance Data

*"Quality Since
1910"*

MODEL EXAMPLE: 10H-3.0T-SR-RH-20

**Gear Case and
Shaft Designation**

10H = Series 1000H with 1-1/2" Output Shaft)

Hydraulic Motor Designation

3.0T, 6.2T, 9.6T

IS - Input Shaft

Gear Ratios

10:1, 20:1, 27:1, 40:1

Shaft Position

RH - Right Hand (Standard)

LH - Left Hand

Speed Reducer

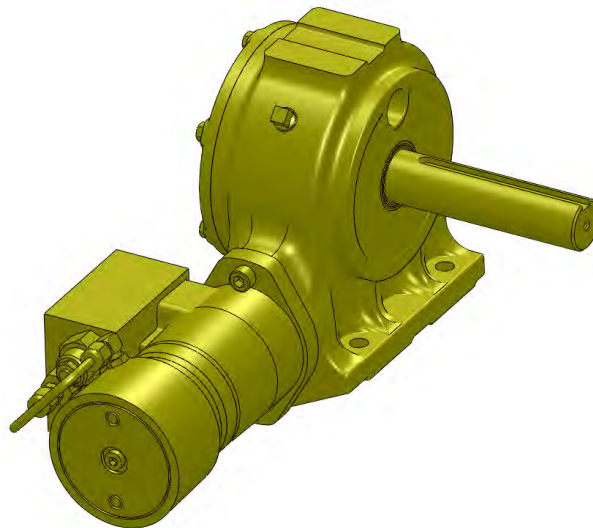

BLOOM™ WINCH



Series 1000H

"Quality Since 1910"

Bloom Hydraulic Speed Reducers With Hydraulic Safety Brake Model Selection from Performance Data

10:1 RATIO (optional)

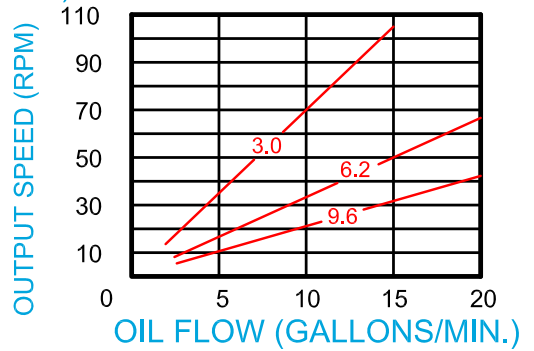
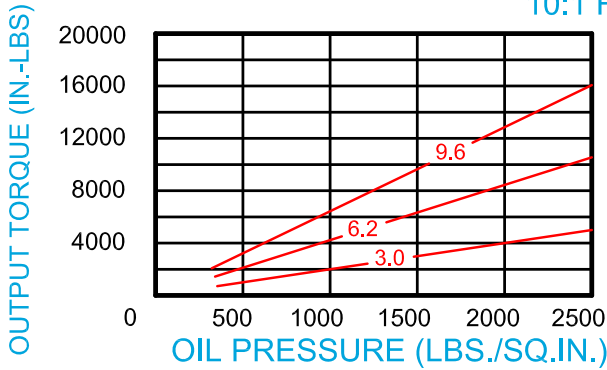

20:1 RATIO (standard)

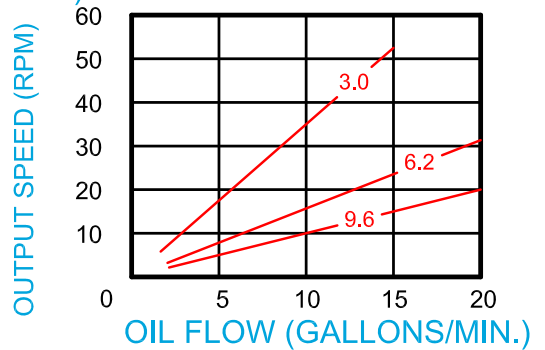
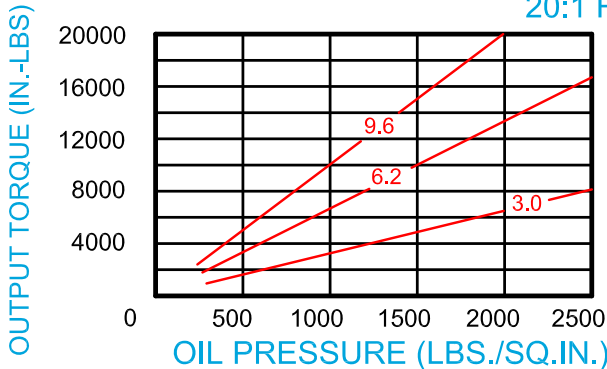

27:1 RATIO (optional)

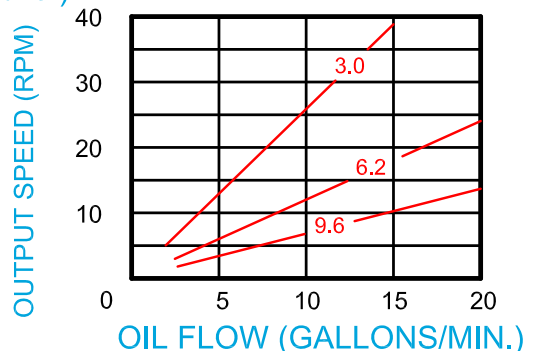
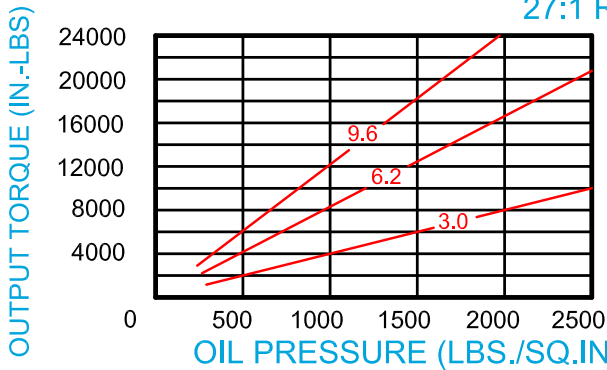

40:1 RATIO (optional)

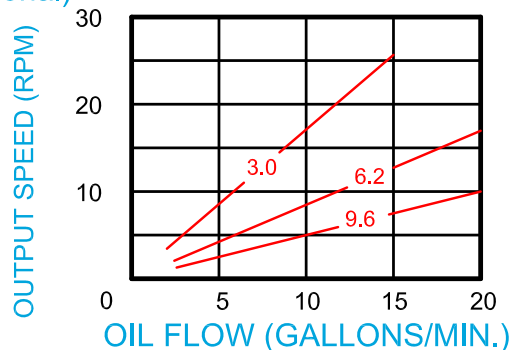
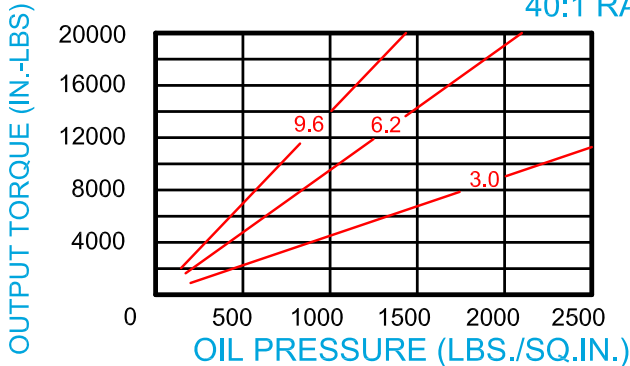



Dimensional Drawings

Series 1000H Speed Reducer

“Quality Since
1910”

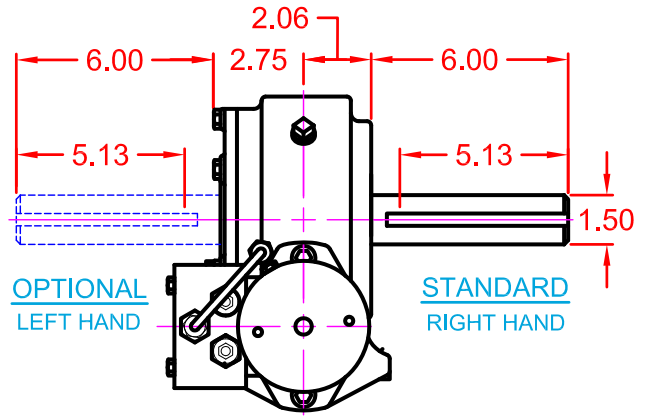
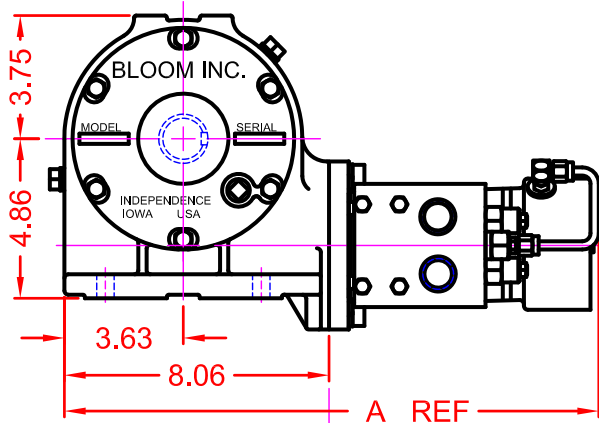

**INPUT SHAFT
MODEL**

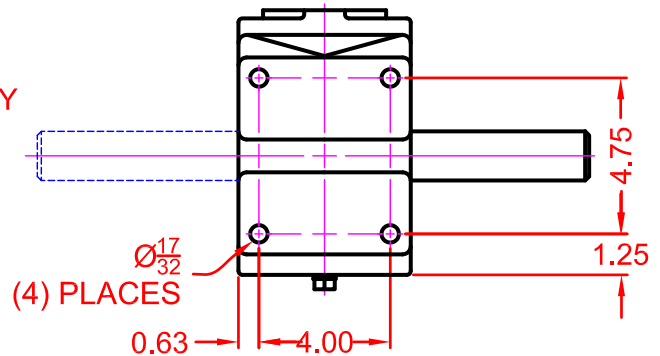
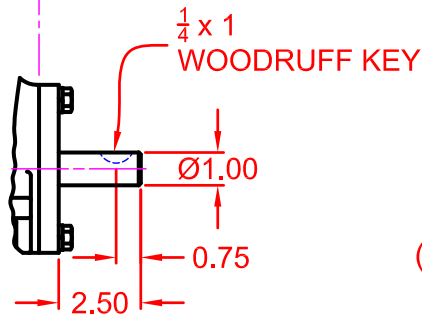

MOTOR DESIGNATION	3.0T	6.2T	9.6T
(A) DIMENSION	15.91	16.28	16.53

OVERHUNG LOAD ON OUTPUT SHAFT AT 100 RPM (LB.)	Ø1.50 SHAFT
1" FROM FACE OF GEARCASE	750
2" FROM FACE OF GEARCASE	600
3" FROM FACE OF GEARCASE	500

BLOOM™ WINCH

1000H Series Model Selection

3.0T MOTOR
10H-3.0T-SR

6.2T MOTOR
10H-6.2T-SR

9.6T MOTOR
10H-9.6T-SR

INPUT SHAFT MODEL
10-IS-SR

BLOOM™ WINCH

Correct choice of Directional Control Valves for Bloom Winches

Motor Spool Valve – Work Ports are **open** to tank in neutral position.
Use on all winches that use Counter Balance Valves to hold load.

*Winches require ridged mounting plate.
See owner's manual for information about proper mounting plate thickness or call Bloom Sales Engineer at factory.

WARNING!

Goods are not intended for use in the moving or lifting of persons!

The winches described herein are neither designed nor intended for use or application to equipment used in the lifting or moving of persons and it is understood that all such use shall be at the sole risk of the user.

The cable clamps on winches are not designed to hold rated loads. A minimum of 5 wraps of cable must be left on drum barrel to guarantee holding of rated load.

Applications of winch where life would be endangered by any event are not recommended.



BLOOM Manufacturing Inc. Winch Division

1443 220th Street,, Independence, Iowa 50644

FAX 319-827-1140 PHONE 319-827-1139

www.bloommfg.com

©Copyright 2015 Bloom Mfg. Inc.