

## Series LS20K

### **Hydraulic Planetary Cable Winches**

Lift-Safe® hydraulic winches are specifically designed for lifting applications and optimum load control. Engineered for enhanced safety with redundant braking systems, and available in a variety of configurations. Lift-Safe® winches utilize the **DUET-SAFE® Double Action Braking System** to provide both static and dynamic braking. **Series LS20K** direct drive winches are used for industrial pulling and hoisting applications, fishing boats, marine craft, drill rigs, small cranes, factory material handling and rear load waste handlers.

**Powerful Fast**  
**UP TO 12,800 POUNDS**  
**CAPACITY**

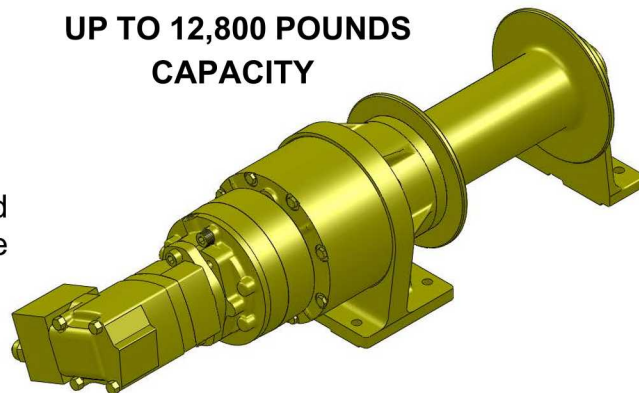

## Lift-Safe® Hydraulic Cable Winches – Standard Features

- |                       |                                                                                                                                                                                                                                                                                                                                                                                  |
|-----------------------|----------------------------------------------------------------------------------------------------------------------------------------------------------------------------------------------------------------------------------------------------------------------------------------------------------------------------------------------------------------------------------|
| <b>MOTOR-BRAKE</b>    | - <b>DUET-SAFE® Double Action Braking System</b> combines a powerful spring applied, hydraulic released motor-brake with a double counter balance brake valve to automatically hold loads when hydraulic pressure is released and control speed during lowering operations. Winch is ideal for high speed lifting and pulling applications or wherever load holding is critical. |
| <b>GEAR CASE</b>      | - Made of high strength cast iron and steel. Completely sealed for oil enclosed operation and to keep dirt out.                                                                                                                                                                                                                                                                  |
| <b>PLANETARY GEAR</b> | - High Efficiency Double Reduction – Rugged - Built to Last.                                                                                                                                                                                                                                                                                                                     |
| <b>GEAR RATIO</b>     | - 17:1 standard.                                                                                                                                                                                                                                                                                                                                                                 |
| <b>BEARINGS</b>       | - Drum Shaft is supported by two heavy duty oil lubricated bearings in gear case, and one permanently sealed ball bearing in end housing.                                                                                                                                                                                                                                        |
| <b>DRUM SHAFT</b>     | - 1-1/2" diameter heat-treated alloy steel minimum tensile strength 150,000 psi.                                                                                                                                                                                                                                                                                                 |
| <b>CABLE DRUM</b>     | - Tough all steel construction resists breakage or warping.                                                                                                                                                                                                                                                                                                                      |



# BLOOM

Manufacturing Inc.

Winch Division

**Lifting  
Pulling  
Hoisting**

Toll Free Number: 1-800-394-1139

www.bloommfg.com

**"Custom Engineered Solutions"**

1443 220<sup>th</sup> Street,, Independence, Iowa 50644 • FAX: 319-827-1140 • PHONE: 319-827-1139

## Series LS20K Model Selection from Performance Data

**MODEL EXAMPLE: LS20K-6.2M-L8-17**

LS20K = Lift-Safe® Series LS20K  
with 1-1/2" Drum

K = Fail-Safe Brake with  
Separate Motor

Hydraulic Motor Designation  
4.9M, 6.2M

Gear Ratio  
5:1, 17:1

Drum Designation  
S8, L8, XL10, XL12 & XL14  
With 4" core

### DRUM CAPACITY

CABLE DIAMETER (IN.)	1/4	5/16	3/8	7/16	1/2
DRUM "S8" CAPACITY (FT.)	260	160	105	75	55
DRUM "L8" CAPACITY (FT.)	390	240	160	110	80
DRUM "XL10" CAPACITY (FT.)	840	550	340	250	170
DRUM "XL12" CAPACITY (FT.)	1320	840	580	380	280
DRUM "XL14" CAPACITY (FT.)	1900	1180	760	540	410

### CAPACITY FEET

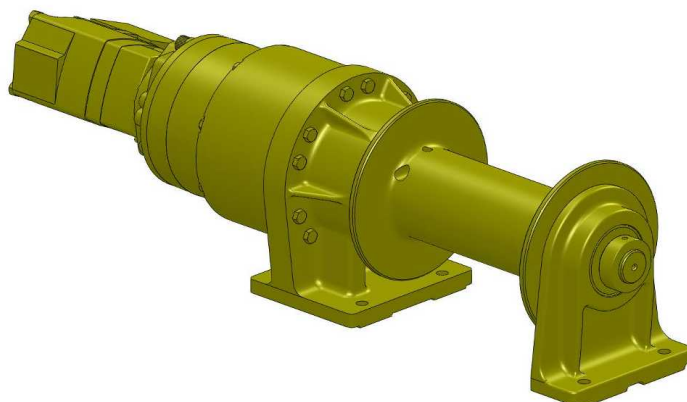

# Lift Safe® Planetary Cable Winches

## Series LS20K W/ 4" Core

With Hydraulic Fail-safe Brake

Model Selection from Performance Data



"Quality Since 1910"

### 5:1 RATIO (optional)

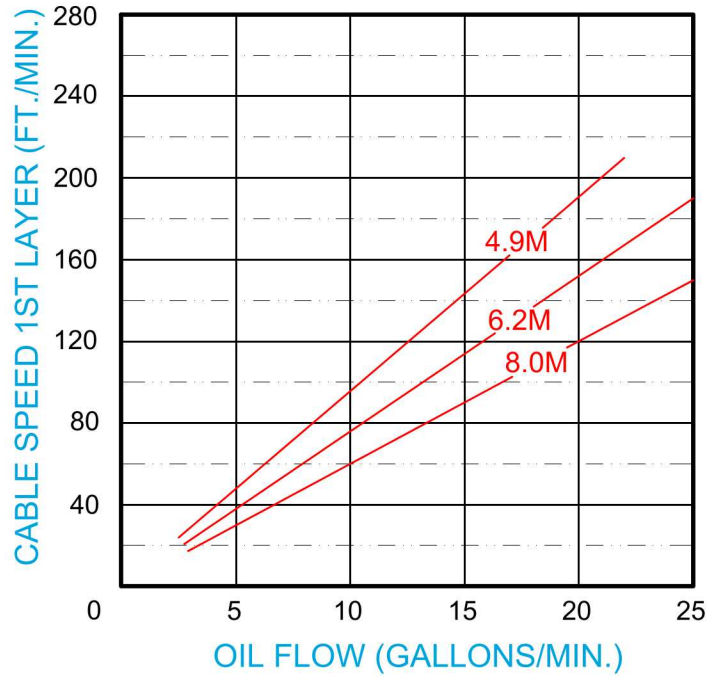
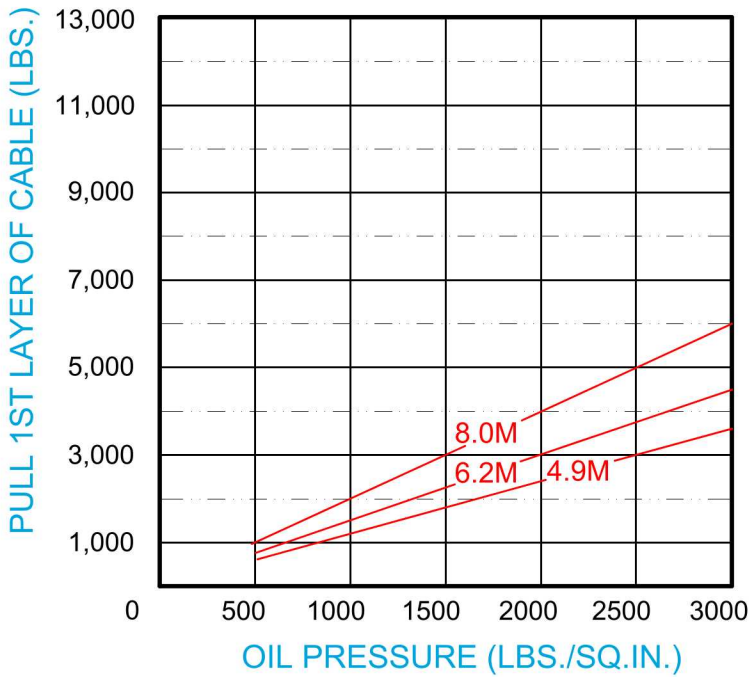

### 17:1 RATIO (standard)

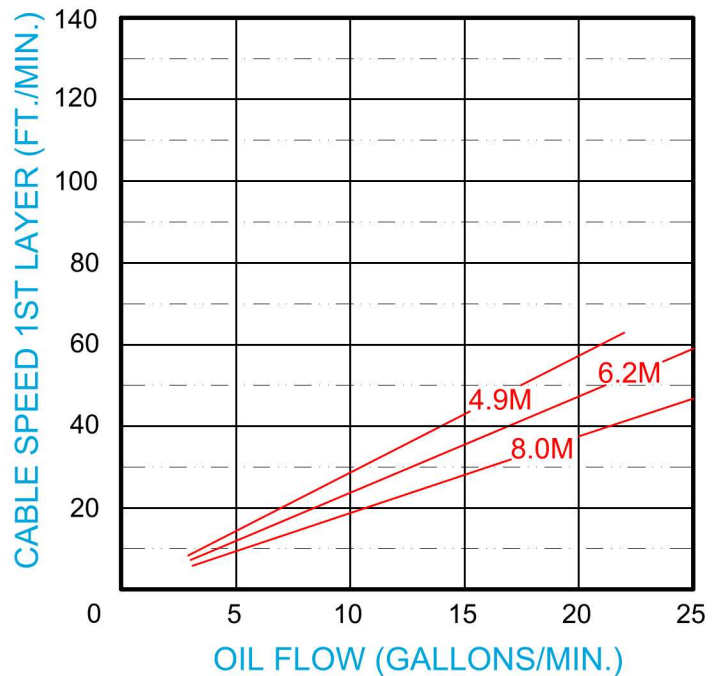
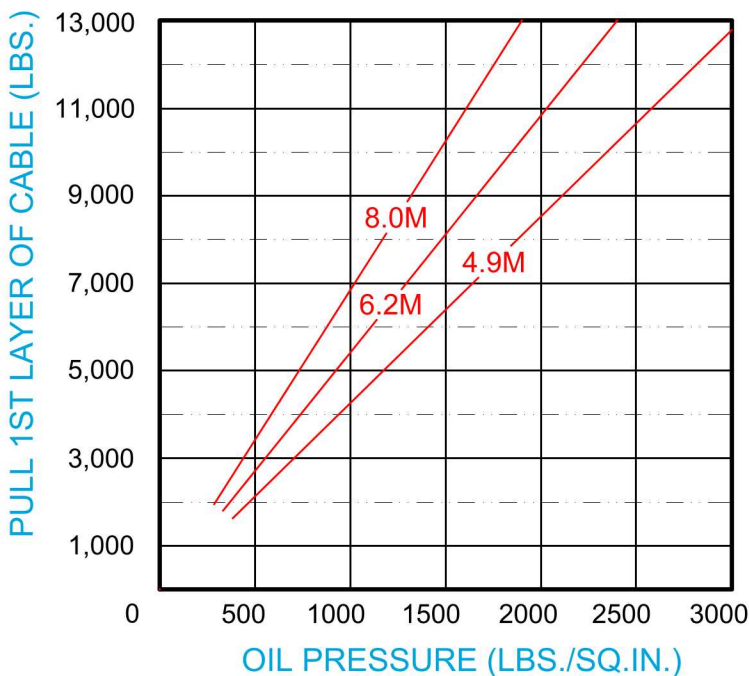

## Dimensional Drawings

Series LS20K With S8 and L8, XL10, XL12 and XL14 Drum  
Base Mount Model - Direct Drive

### With S8 & L8 Drum

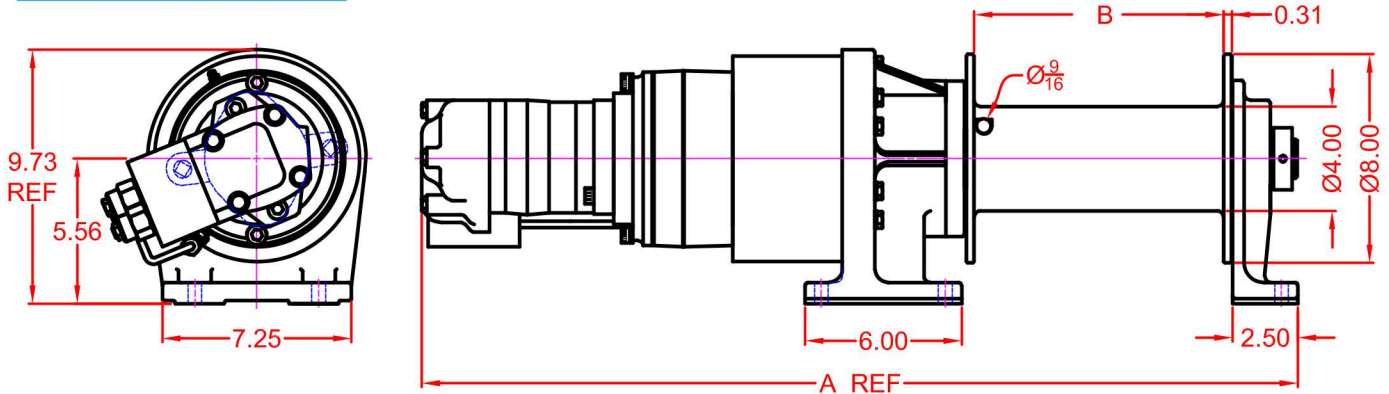

MOTOR DESIGNATION	A DIMENSION	
	4.9	6.2
S8 DRUM	30.40	30.58
L8 DRUM	33.40	33.58

DRUM DESIGNATION	WINCH DIM.	
	B	C
S8	6.56	9.88±.06
L8	9.56	12.88±.06

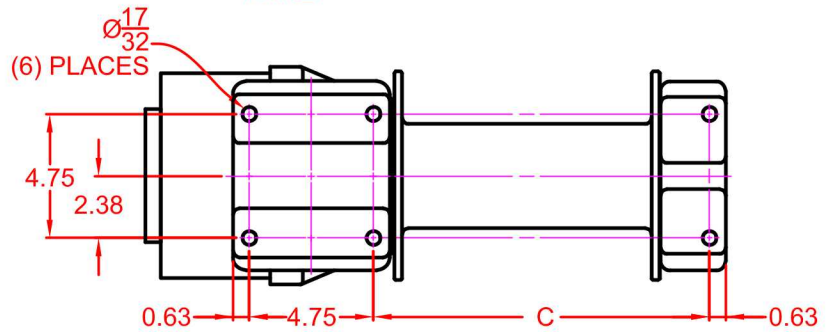

### With XL10, XL12 & XL14 Drum

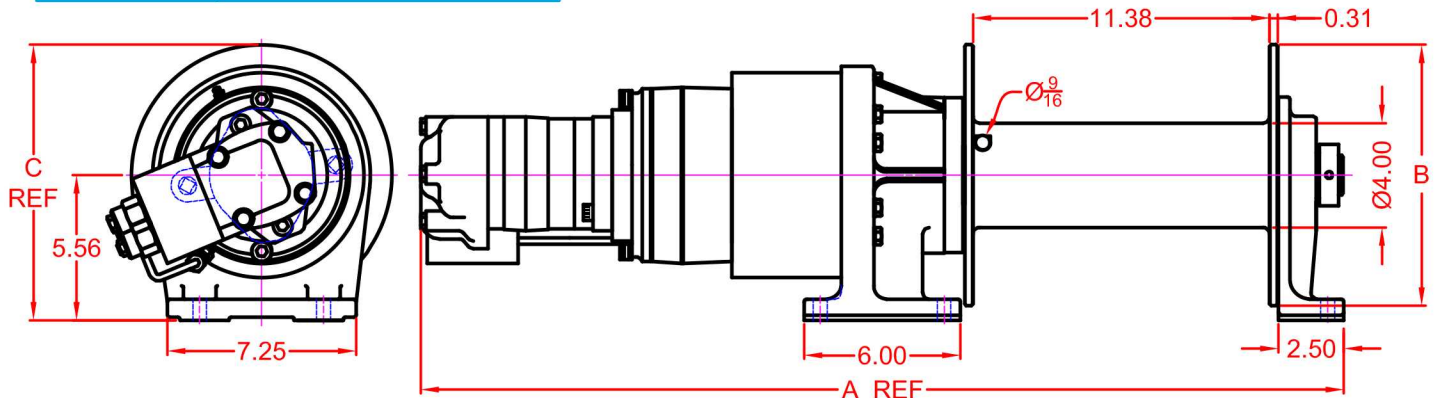

MOTOR DESIGNATION	4.9	6.2
A DIMENSION	35.21	35.39

DRUM DESIGNATION	WINCH DIM.	
	B	C
XL10	10	10.56
XL12	12	11.56
XL14	14	12.56

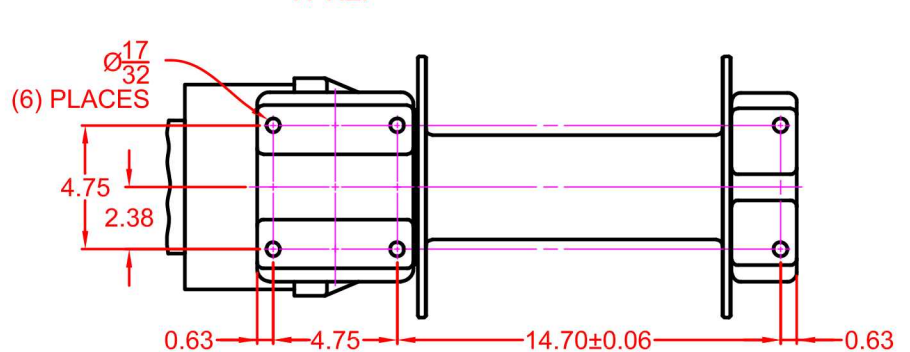

# LIFT-SAFE®

## Correct choice of Directional Control Valves for Lift-Safe® Winches

All **Lift-Safe®** Winches require a **Motor Spool Control Valve**.

That is the valve's work ports are **open** to tank in neutral position.

\*Winches require ridged mounting plate.  
See owner's manual for information about proper mounting plate thickness or call Bloom Sales Engineer at factory

### **WARNING!**

Goods are not intended for use in the moving or lifting of persons!

The winches described herein are neither designed nor intended for use or application to equipment used in the lifting or moving of persons and it is understood that all such use shall be at the sole risk of the user.

The cable clamps on winches are not designed to hold rated loads. A minimum of 5 wraps of cable must be left on drum barrel to guarantee holding of rated load.

Applications of winch where life would be endangered by any event are not recommended.



## **BLOOM Manufacturing Inc.** **Winch Division**

1443 220<sup>th</sup> Street,, Independence, Iowa 50644

FAX 319-827-1140 PHONE 319-827-1139