

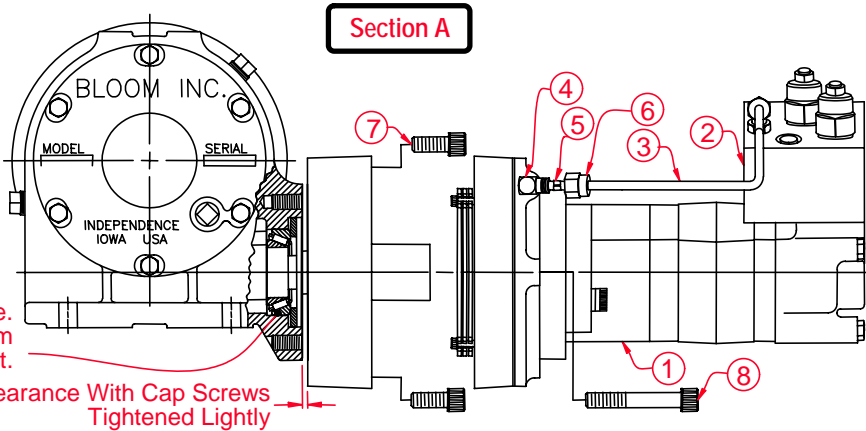

- 1) Drain oil from gear case.
- 2) Loosen set screw in eccentric collar, then turn collar counter-clockwise with punch to release it from bearing and shaft.
- 3) Remove end housing from drum shaft.
- 4) Remove retaining ring and drum from shaft.
- 5) Remove wear block from gear case.
- 6) **Brake & Motor Removal** (Section A)
 - a) Loosen jam nuts and locking nuts to remove brake line.
 - b) Remove (3) 3/8" X 2-1/2" (2000 motor) socket head cap screws or (4) 5/16" X 3" (AM motor) hex head cap screws. Remove counterbalance valve.
 - c) Loosen and remove (2) 1/2" X 1-1/2" (2000 motor) or (2) 1/2" X 1-1/4" (AM motor) socket head cap screws. Remove motor from back of brake unit.
 - d) Loosen and remove (2) 1/2" X 3" socket head cap screws from back of brake housing. Split brake unit into 2 parts.
 - e) Loosen and remove (2) 7/16" X 1" socket head cap screws and remove brake housing from gear case.
- 7) Remove worm shaft and bearings from gear case.
- 8) Remove gear case cover.
- 9) Remove bronze gear and drum shaft as a unit being careful not to damage shaft seal.

Note: Bronze gear is press fit on shaft. **DO NOT** remove unless absolutely necessary.

- ① Motor
- ② Counterbalance Valve
- ③ Hydraulic Tube
- ④ Elbow
- ⑤ Tapered Split Ring
- ⑥ Nut
- ⑦ Socket Head Cap Screw
- ⑧ Socket Head Cap Screw



- 1) Clean gear case and all parts thoroughly, inspect oil seal and replace if worn or scored.
- 2) If bronze gear has been removed from shaft, care should be used to press the gear onto the shaft squarely. Press gear and keys onto shaft simultaneously. Locate end of gear hub (the set screw side) 3/4" on 1-1/2" shaft models (Section B).
- 3) Install gear and shaft assembly (with bearings) into gear case carefully to prevent damage to the shaft seal.
- 4) Bolt cover to gear case without shim gaskets. Tighten the screws lightly and evenly. Measure clearance between cover and gear case with feeler gage and remove cover. For proper bearing pre-load, install shim gaskets (red - .002", blue - .005", brown - .010") onto cover as required with a thickness that is .003" to .005" less than the measurement.

Section B

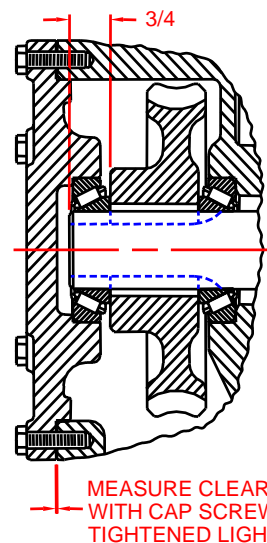

Do Not Use Hammer To Install Bronze Gear Onto Shaft

- Re-bolt cover securely. Check bearing thrust by turning drum shaft. Shaft must turn freely but with just a slight amount of resistance.
- 5) Install bearing cone (.75" diameter inside dimension) into bearing pocket. Install worm shaft. Be sure that the shaft end opposite the motor is seated properly in the bearing cone. Install bearing cone and cup on motor end **being sure large end of bearing cone is seated against worm gear shoulder** (Section C).

Section C

- ① Motor
- ② Counterbalance Valve
- ③ Hydraulic Tube
- ④ Elbow
- ⑤ Tapered Split Ring
- ⑥ Nut
- ⑦ Socket Head Cap Screw
- ⑧ Socket Head Cap Screw

Note The Location of The Cup & Cone. The Cone Is Installed Onto The Worm Shaft First.

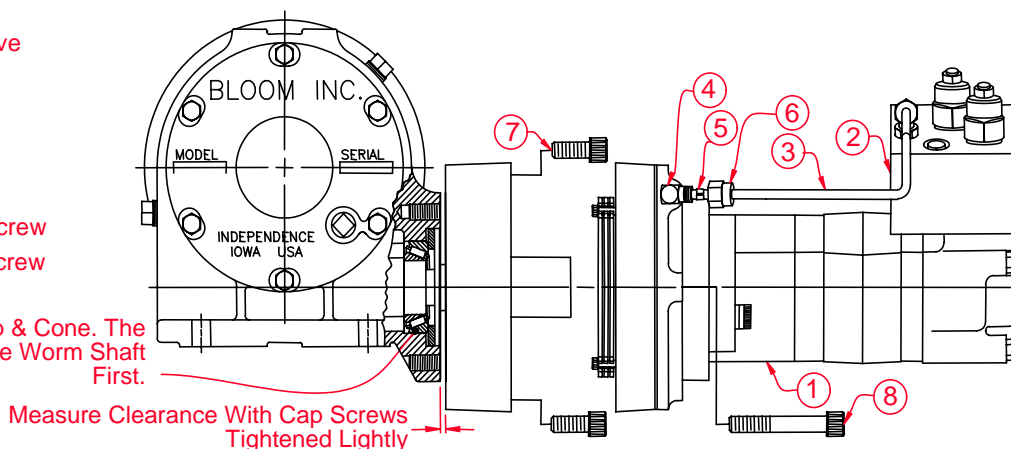

6) Brake & Motor Assembly

- a) Install round head woodruff key into brake output shaft. Make sure thrust spacer is against bearing. Bolt front brake housing to gear case without shim gaskets with (2) 7/16" X 1" socket head cap screws. Tighten the screws lightly and evenly. Measure clearance with a feeler gage and remove front brake housing (Section B). For proper bearing pre-load, install shim gaskets (red - .002", blue - .005", brown .010") as required with a thickness that is .003" - .005" less than the measurement. Re-bolt front brake housing securely.
 - b) Bolt back half of brake housing to front half with the (2) 1/2" X 3" socket head cap screws.
 - c) Install square head woodruff key into motor shaft and bolt motor to back of brake using (1) (W-239) brown motor gasket and (2) 1/2" X 1-1/2" (2000 motor) or (2) 1/2" X 1-1/4" (AM motor) socket head cap screws.
 - b) Bolt double counterbalance valve to motor manifold bearing end cap using O-Rings provided and (3) 3/8" X 2-1/2" (2000 motor) socket head cap screws or (4) 5/16" X 3" (AM motor) hex head cap screws.
 - c) Install brake line into 7/16" male elbows on counterbalance valve and brake (If installing a new brake line it may be necessary to cut brake line to fit). Tighten jam nuts on male elbows to hold in place. Tighten locking nuts on elbows to hold brake line in place. Turn nut only until tapered split ring starts to come through the back side or the brake line side of the nut.
- 7) Grease drum shaft with multi-purpose lithium grease or equivalent and install wear block and drum. Install retaining ring. Place end housing assembly on drum shaft and slide toward drum until there is about 1/16" clearance between housing and drum. Place collar on bearing being sure it is properly seated on bearing eccentric. Turn clockwise with punch until bearing and shaft are held tight, then tighten set screw.
- 8) Base Mounted: Fill gear case with (1) pint, All Other Mounting Positions: Fill gear case with (2) pints **Bloom ULLTRA-LUBE NO. 601 TRANS-WORM GEAR OIL**; available from Bloom in pints or quarts. The hardened steel worm shaft must run in oil. For emergency situations when **Bloom ULLTRA-LUBE NO. 601** is not immediately available, use Phillips 66 Company SAE grade 80W90 superior multi-purpose gear oil (Phillips 80W90 SMP) meeting API classification GL-5 or equivalent competing brand. Continuous use of oil other than **Bloom ULLTRA-LUBE NO. 601** or Phillips 80W90 SMP may shorten the life of the gears. **DO NOT** mix **Bloom ULLTRA-LUBE NO. 601** or Phillips 80W90 SMP with more than 50% of any other kind of oil.