

BLOOM MANUFACTURING INC.

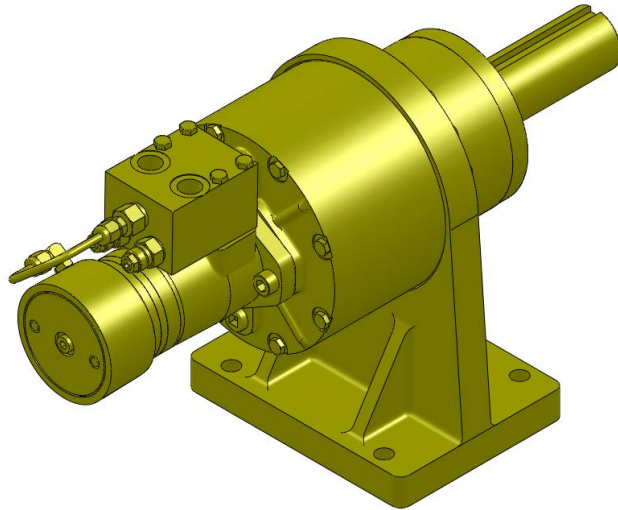

Safety, Warranty, Maintenance & Repair, Installation and Operation Manual

Bloom™ Hydraulic Speed Reducers 2200 Series



All Bloom Speed Reducer have the model and serial number stamped on the gear case . Please take a few minutes to record these numbers for future use. You will need these numbers for ordering parts or gathering service information from the factory:

Model # _____ Serial # _____

Thank you for your purchase of a quality Bloom product !

This Manual Must Be Kept With The Speed Reducer At All Times And New Operators Must Read And Understand It.

Bloom Manufacturing Inc.

TABLE OF CONTENTS

1. General Safety Requirements
2. Warranty
3. Maintenance & Repair
 - (a) Clean and Inspect
 - (b) Oil Change Information
 - (c) Oil Level
 - (d) Recommended Gear Oil
 - (e) Attachments (parts list, assembly)
4. Speed Reducer Break In
5. Speed Reducer Installation
6. Speed Reducer Operation
 - (a) Automatic Safety Brakes & Adjustment

Please note that not all of the above sections apply to each model purchased

Merchandise may not be returned without approval from factory. The customer will be charged for placing the returned goods in salable condition plus a restocking charge of 25%. All returns must be shipped prepaid.

Section 1

General Safety Requirements



THIS SYMBOL MEANS

- Attention!
- Become Alert!
- Your Safety Is Involved



Take Note! This Safety Alert Symbol Found Throughout This Manual Is Used To Call Your Attention To Instructions Involving Your Personal Safety And The Safety Of Others. Failure To Follow These Instructions Can Result In Injury Or Death.

SIGNAL WORDS: Note the use of the signal words DANGER, WARNING AND CAUTION with the safety messages. The appropriate signal word for each has been selected using the following guidelines:

DANGER: Indicates an imminently hazardous situation that, if not avoided, will result in death or serious injury. This signal word is to be limited to the most extreme situations typically for machine components which, for functional purposes, cannot be guarded.

WARNING: Indicates a potentially hazardous situation that, if not avoided, could result in death or serious injury, and includes hazards that are exposed when guards are removed. It may also be used to alert against unsafe practice.

CAUTION: Indicates a potentially hazardous situation that, if not avoided, may result in minor or moderate injury. It may also be used to alert against unsafe practices.



WARNING

Failure to Heed The Following Warnings May Result In Serious Injury Or Death

- Bloom Speed Reducers are not to be used to lift, hoist, or move people. If your task involves lifting or moving people, you must use the proper equipment, not this speed Reducer.
- Bloom products are sold on the strict understanding that all products selection is the full responsibility of the purchaser.
- Bloom accepts no liability for the use, misuse or incorrect application of its products.
- Make sure that all equipment is maintained properly.
- Ensure the correct equipment is obtained and installed for the application
- Ratings shown in Bloom literature are applicable only to new products.
- In general, products displayed in Bloom literature are used as parts of a system. As a result, we can only recommend within the working load limits, or other stated limitations, the use of products for this purpose.
- No equipment should be installed, operated, or maintained by any person who has not carefully read all contents of this manual. Serious physical injury or property damage can result from failure to read and apply the instructions contained therein. Therefore, we urge you to read all operating instructions and warnings carefully. If any instruction or warning is not clear, or if you feel you need additional information, please contact Bloom Mfg Inc. This manual should not be understood to prepare you for every possible situation. It is the owner's and user's responsibility to determine the suitability of a product for a particular use. Applicable industry, trade association, federal, state, and local regulations should be reviewed.
- Working load limits or safety factors for each Bloom product may be affected by wear, misuse or environmental conditions. Regular Inspection must be conducted to ensure the equipment continues to meet the published standards.

If you have questions not answered in this manual or require additional copies or the manual is damaged, please contact Bloom Mfg., Inc., 1443 220th Street, Independence, Iowa 50644.

This sample manual is based upon general industry considerations and does not take into account product or manufacturer specific exposures or needs. This sample manual may not be adopted by a product manufacturer as its manual, but may be used by the manufacturer in the process of developing its own manual, based upon its specific products and operations, after consulting with its advisor.

Section 2

Warranty



LIMITED NINETY (90) DAY WARRANTY FOR HYDRAULIC SPEED REDUCERS

Effective date January 1, 1999

Bloom Mfg. Inc., Independence, Iowa 50644, provides the following limited ninety (90) day warranty on its product to the purchaser of this product and to any person to whom such product is transferred during the duration of this warranty. The warrantor's obligation shall be limited to repairing or replacing at the factory in Independence, Iowa, USA, any part or parts which shall within the ninety (90) day period hereinafter specified be returned to it with transportation prepaid and which upon examination by Bloom Mfg. Inc. shows to have been defective. This warranty shall not apply if:

- (a) the product has been altered, repaired or modified outside the warrantor's factory in any way that would adversely affect its operation.

- (b) the product has been subject to careless or negligent misuse, damage or use of improper oil while in the possession of the purchaser or any person to whom the product was transferred by the purchaser or was installed or operated other than in accordance with the manufacturer's operating instructions.
- (c) the product was used with accessories not recommended by Bloom Mfg. Inc. or for loads in excess of those listed as rated for the product.
- (d) in the case of hydraulic motors, Bloom Mfg. Inc. will not accept responsibility and warranty will be subject to manufacturer's warranty.

The ninety (90) day limited warranty period shall commence with the date the product is sold to the purchaser by the dealer or if this date cannot be established, the date the product was sold by Bloom Mfg. Inc. to the dealer.

The implied warranties of merchantability and fitness for particular purpose are limited to the duration of this warranty - ninety (90) days - after said (90) days, Bloom Mfg. Inc. expressly disclaims any warranty or merchantability or fitness for any particular purpose.

Purchase or other acceptance of the product by the claimant shall be on the condition and agreement that Bloom Mfg. Inc. shall not be liable for incidental or consequential or contingent damage, secondary charges or loss or expense resulting from any alleged defect, failure of article to operate properly, or for the negligence of others or damages of any kind.

Bloom Mfg. Inc. is not responsible for the cost, of removal of product, damages due to removal or any other expenses incurred in shipping the product to or from Bloom Mfg. Inc. or the installation of the repaired or replacement product. The consumer must bear these expenses.

To make a claim under this warranty, write directly to Bloom Mfg. Inc., Independence, Iowa 50644, identifying the product and giving its location and follow the company's return instructions which will be provided by the company. Bloom Mfg. Inc. will make its best efforts to repair or replace the product, if found to be defective within the terms of this warranty, within sixty (60) days after return of the product to the company.

This warranty is exclusive and in lieu of all other warranties whether written, oral or implied (including any warranty of merchantability or fitness for a particular purpose.

Section 3	Maintenance & Repair	
------------------	---------------------------------	---



CAUTION

- **Make sure that the hydraulic hoses have been disconnected before servicing unit**

A Speed Reducer, like other types of machinery, needs to have regular maintenance if it is to perform properly, give lasting value, and provide safe operation.

(a) Clean and Inspect

Thoroughly clean all of the parts in a good grade of cleaning solvent; one that is not flammable, not toxic and will not cause skin rashes. If necessary, use rubber gloves. Inspect all parts for wear, nicks, scratches and damage that would render them unusable. If a part is questionable, it is better to replace it rather than take a chance on premature failure when the Speed Reducer is placed back in service. Always replace O-rings and seals, and it is a good idea to use new roll pins as well. Sometimes it is permissible to reuse bearings and bushings...it depends on how much use they have had. The ball bearings should not exhibit any surface irregularities. If the ball bearings show any sign of spalling, corrosion, discoloration, material displacement or abnormal wear, the bearings should be replaced. If the Speed Reducer was disassembled only to replace damaged seals after a short period of service, it is not necessary to replace the bearings.

Experience and common sense, along with a good inspections, will determine if they can be used again. Always coat O-Rings, bearings, bushings and the rubber parts of seals with oil during assembly. Use a light coat of thread sealing compound on pipe fittings and plugs.

(b) Oil Change Information:

The Speed Reducer vent/fill and drain plugs are located at the base of the face plate. Oil should be changed every 100 hours of operating time, or every six months, whichever comes first.

OIL CAPACITY CHART

Speed Reducer Series	Base Mounted Position	All Other Mounting Positions
2200	4 pints	4 pints

(c) Oil Level:

To check the oil level, remove the level plug. The oil should be level with the bottom of this opening. If more oil is needed, use the recommended gear oil listed below.

(d) Recommended Gear Oil:

Use Bloom ULLTRA-LUBE NO. 601 trans-worm gear oil; available from Bloom in pints or quarts. For emergency situations when Bloom ULLTRA-LUBE NO. 601 is not immediately available, use Phillips 66 Company SAE grade 80W90 superior multi-purpose gear oil (Phillips 80W90 SMP) meeting API classification GL-5 or equivalent brand. Continuous use of oil other than Bloom ULLTRA-LUBE NO. 601 or Phillips 80W90 SMP oil may shorten the life of the gears. DO NOT mix Bloom #601 or Phillips 80W90 SMP with more than 50% of any other kind of oil.

Section 4

Speed Reducer Break In



CAUTION

- Speed Reducers, like any other kind of machinery, require a “break in” to perform well and to maximize their life.
- The following guidelines should be used in the break in of Bloom Speed Reducers.
- Do not run the speed Reducer at high speeds when performing this operation.
- Do not exceed one half rated load for the first thirty minutes of operation. This will ensure that the worm and gear have an opportunity to wear in properly.
- Periodically, check the gearbox for temperature rises and allow the Speed Reducer to cool down if necessary.



CAUTION

- To must make sure that your speed Reducer is securely mounted in order for it to function properly and to ensure safe operation.
- The mount must be flat to ensure proper alignment of the gearbox.
- Speed Reducers must never be fastened directly to the frame of a truck. Mounting brackets should be used.
- With a hydraulically driven Speed Reducer, make sure the hydraulic system is clean and that all components function properly, especially the relief valve.

	Speed Reducer Series
	2200
Base Mount (steel) Thickness	1-1/4"
Capscrews (Hexhead) Size Thread Grade	5/8" 11 UNC 5
Torque / Tightening (foot pounds)	112

- To familiarize yourself with the Speed Reducer, run it for a few minutes to understand the controls and the "feel" of the Speed Reducer. Pay particular attention to the controls and how they operate.
- Make sure you understand which way the Speed Reducer will rotate when the control lever is moved.
- Always make sure that all people are clear of the load before beginning a Speed Reducer operation.
- Do Not attempt to defeat the relief valve.

(a) Automatic Safety Brake:

Bloom 2200 series speed reducer are equipped with an automatic hydraulic failsafe brakes (spring applied hydraulic release) to hold suspended loads.

Spring applied hydraulic release brake automatically holds load when hydraulic pressure is released. There are no adjustments to these brakes. They are adjusted only at the factory. **DO NOT** attempt to change any brake setting in the field. Double counter balance valve adds additional load holding capability by locking hydraulic oil in motor.