

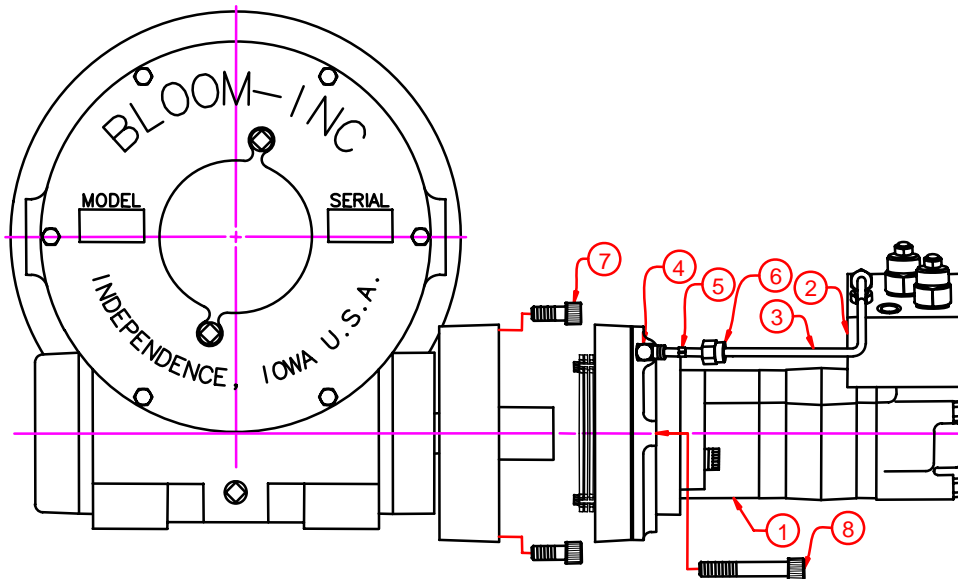

- 1) Drain oil from gear case.
- 2) Loosen set screw in locking collar, then remove locking collar from shaft.
- 3) Remove end housing from drum shaft. If replacement of bushing is required, press bronze bushing out of end housing and remove grease zerk.
- 4) Remove drum from shaft
- 5) Remove keys from drum shaft.
- 6) **Brake & Motor Removal**
  - a) Loosen jam nuts and locking nuts to remove brake line.
  - b) Remove (3) 3/8" X 2-1/2" socket head cap screws. Remove counterbalance valve.
  - c) Loosen and remove (2) 1/2" X 1-1/2" socket head cap screws. Remove motor from back of brake unit.
  - d) Loosen and remove (2) 1/2" X 3" socket head cap screws from front of brake housing. Split brake unit into 2 parts.
  - e) Loosen and remove (2) 1/2" X 1" socket head cap screws and remove brake housing from the motor to gear case adapter.
- 7) Remove hydraulic motor and motor adapter from gear case, being careful not to damage seal in adapter.
- 8) Remove end cap.
- 9) Remove worm shaft and bearings from gear case.
- 10) Remove gear case cover and bearings.
- 11) Remove bronze gear and drum shaft as a unit being careful not to damage shaft seal.
 

Note: Bronze gear is press fit on shaft. DO NOT remove unless absolutely necessary.
- 12) If necessary to replace bronze gear, remove snap ring and press gear off shaft



- ① MOTOR
- ② COUNTERBALANCE VALVE
- ③ HYDRAULIC TUBE
- ④ ELBOW
- ⑤ TAPERED SPLIT RING
- ⑥ NUT
- ⑦ SOCKET HEAD CAP SCREW
- ⑧ SOCKET HEAD CAP SCREW

## Assembly Instructions

## LS14K &amp; LS16K Series Winches

- 1) Clean gear case and all parts thoroughly, inspect oil seal and replace if worn or scored.
- 2) If bronze gear has been removed from shaft, care should be used to press the gear onto the shaft squarely. Slip gear and keys onto shaft simultaneously. Locate gear so that counterbore in gear hub lines up with retaining ring groove in shaft. Install retaining ring.
 

Note: Retaining ring must be completely inside gear counterbore so that bearing shoulder seats against gear hub and not retaining ring.
- 3) Install gear and shaft assembly into gear case carefully to prevent damage to the shaft seal.
- 4) Bolt cover to gear case without shim gaskets. Tighten the screws lightly and evenly. Measure clearance between cover and gear case with feeler gage and remove cover. For proper bearing pre-load, install shim gaskets (red - .002", blue - .005", brown - .010") onto cover as required with a thickness that is .003" to .005" less than the measurement. Re-bolt cover securely. Check bearing thrust by turning drum shaft. Shaft must turn freely but with just a slight amount of resistance.
- 5) Install bearing cup into end cap side of gear case.
- 6) Install O-ring on end cap. Bolt end cap to gear case securely with (2) brown shim gaskets from Motor Adapter Gasket Kit.

- 7) Turn gear case so worm can be installed vertically. Drop bearing cone into gear case and make sure it seats in bearing cup. Install worm into gear case. Insert end of worm through bearing so that bearing seats against worm shoulder.
- 8) Place second bearing cone on worm shaft shoulder. Install bearing cup over cone. Turn worm by hand to make sure it turns freely.
- 9) Bolt motor adapter to gear case without shim gaskets. Tighten the screws lightly and evenly. Measure clearance between adapter and gear case with a feeler gage and remove adapter. For proper bearing pre-load, install shim gaskets (red - .002", blue - .005", brown - .010") onto adapter as required with a thickness that is .003" to .005" less than the measurement. Press worm shaft seal into motor adapter. Install O-ring on adapter and re-bolt securely to gear case.

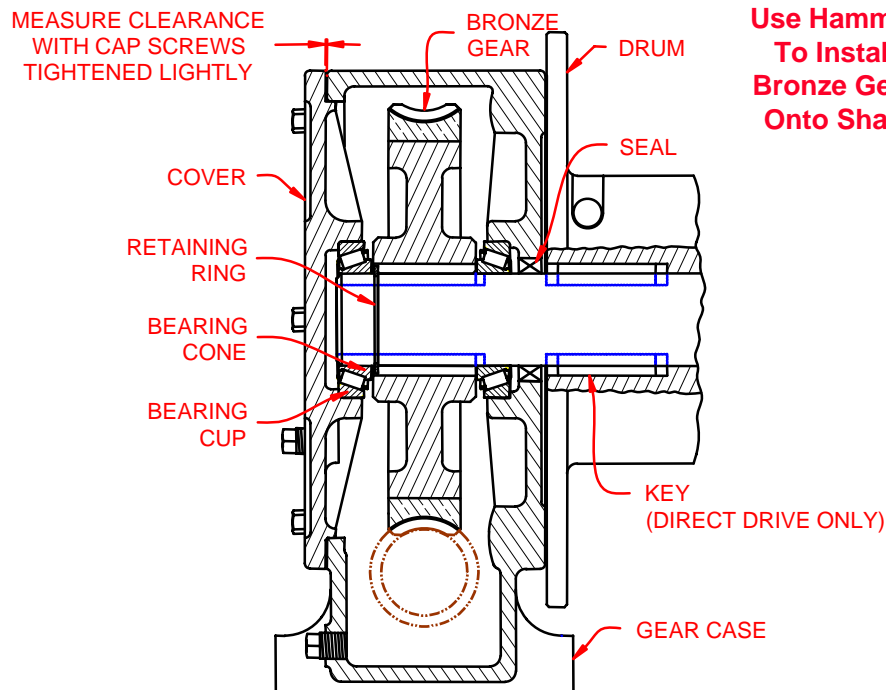

- 10) a) Install 5/16" X 5/16" X 1-1/4" key onto brake shaft. Bolt front brake housing to gear case adapter without shim gaskets with (2) 7/16" X 1" socket head cap screws. Tighten the screws lightly and evenly. Measure clearance with a feeler gage and remove front brake housing. For proper bearing pre-load, install shim gaskets (red - .002", blue - .005", brown .010") as required with a thickness that is .003" - .005" less than the measurement. Re-bolt front brake housing securely.
- b) Bolt back half of brake housing to front half with the (2) 1/2" X 3" socket head cap screws.
- c) Install 5/16" X 5/16" X 1-1/4" key onto motor shaft and bolt motor to back of brake using (1) (W-239) brown motor gasket and (2) 1/2" X 1-1/2" socket head cap screws.
- d) Bolt double counterbalance valve to motor manifold bearing end cap using O'Rings provided and (3) 3/8" X 2-1/2" socket head cap screws.
- e) Install brake line into 7/16" male elbows on counterbalance valve and brake (If necessary cut brake line to fit). Tighten jam nuts on male elbows to hold in place. Tighten locking nuts on elbows to hold brake line in place. Turn nut only until tapered split ring starts to come through the back side or the brake line side of the nut.
- 11) Install keys in drum shaft. Grease drum shaft with multi-purpose lithium grease or equivalent and install drum.
- 12) If bronze bushing in end housing has been removed, press in new bushing. Hone inside diameter of bushing to 2.252 - 2.253". Place drill in grease zerk hole and drill a 1/4" hole through bushing. Install grease zerk.
- 13) Install end housing on drum shaft. Leave about 1/16" clearance between drum and end housing. Place locking collar against end housing and tighten set screws.
- 14) Base Mounted: Fill gear case with (4) pints, All Other Mounting Positions: Fill gear case with (6) pints **Bloom ULLTRA-LUBE NO. 601 TRANS-WORM GEAR OIL**; available from Bloom in pints or quarts. The hardened steel worm shaft must run in oil. For emergency situations when **Bloom ULLTRA-LUBE NO. 601** is not immediately available, use Phillips 66 Company SAE grade 80W90 superior multi-purpose gear oil (Phillips 80W90 SMP) meeting API classification GL-5 or equivalent competing brand. Continuous use of oil other than **Bloom ULLTRA-LUBE NO. 601** or Phillips 80W90 SMP may shorten the life of the gears. **DO NOT** mix **Bloom ULLTRA-LUBE NO. 601** or Phillips 80W90 SMP with more than 50% of any other kind of oil.

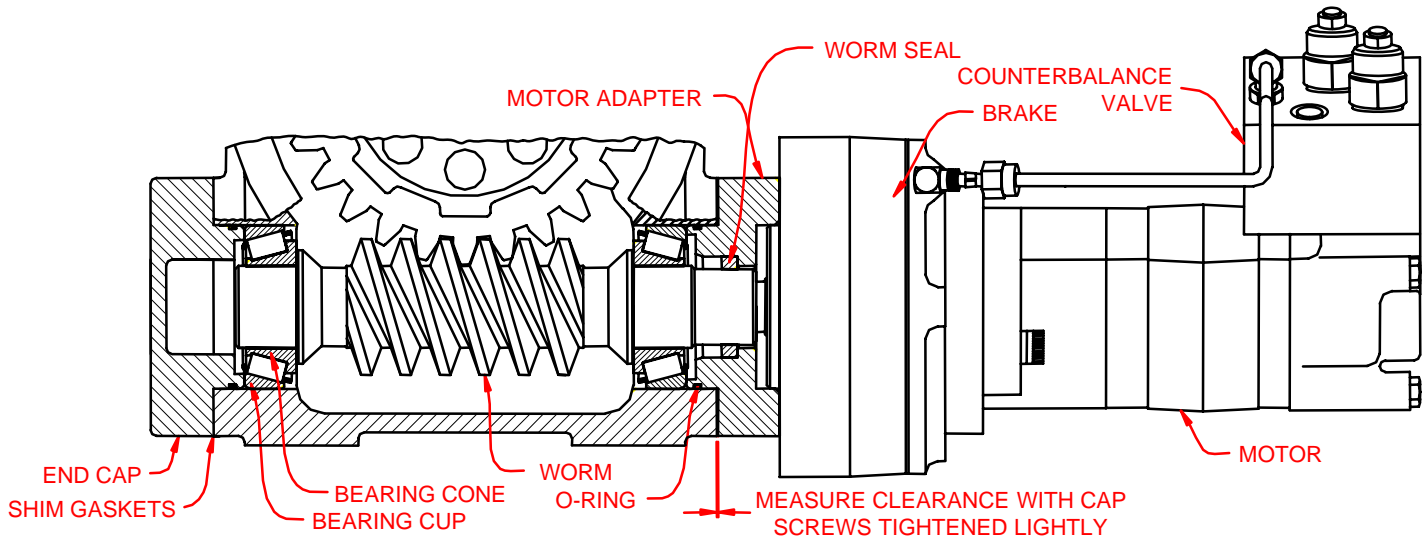

- ① MOTOR
- ② COUNTERBALANCE VALVE
- ③ HYDRAULIC TUBE
- ④ ELBOW
- ⑤ TAPERED SPLIT RING
- ⑥ NUT

