

BLOOM™ WINCH



Series 1000C Galv

HYDRAULIC CABLE WINCHES

The rugged construction and versatility of **Series 1000C Galv** makes it adaptable to a wide range of applications. **Series 1000C Galv** winches are equipped with a sliding clutch to allow free-spooling of the drum for industrial pulling and dragging applications including rear of cab and front mounting on ½ to 1½ ton trucks, flat bed trailers, factory material handling, mining and logging operations, air freight pullers, off the road tractors, aboard ships and boats.

GALVANIZED

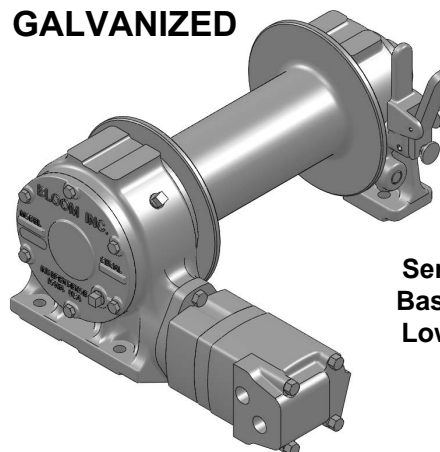

"Quality Since 1910"

Series 1000C Galv
Base Mount shown
Low Profile Mount
Available

**UP TO 12,000 POUNDS
CAPACITY**

Bloom™ Hydraulic Cable Winches – Standard Features

- | | |
|-------------------|---|
| GEAR CASE | - Made of high strength cast iron. Completely sealed for oil enclosed operation and to keep dirt out. |
| WORM SHAFT | - One piece alloy steel hardened and ground for extra durability. Compact design allows hydraulic motor to be coupled directly to worm. |
| WORM GEAR | - High tensile aluminum-nickel alloy bronze. Optimum lead and pressure angles transmit maximum power to the drum. |
| GEAR RATIO | - 20:1 standard, 10:1, 27:1, 40:1 optional ratios provide optimum efficiency in power and speed. |
| BEARINGS | - Worm gear and worm shaft run on tapered roller bearings. Outer end housing has sealed ball bearing. |
| DRUM SHAFT | - 1-1/2" diameter heat -treated alloy steel minimum tensile strength 150,000 psi. |
| CABLE DRUM | - Tough all steel construction resists breakage or warping. |
| CLUTCH | - Series 1000C Galv winch comes equipped with heat-treated dog type clutch to provide free-spooling of the winch drum. Positive lock-in and lock-out. |

CAUTION:

This winch model does not include any kind of holding brake. If your application requires a holding brake choose series 1000KC or 1000HC winches with automatic hydraulic safety brakes.



BLOOM
Manufacturing LLC
Winch Division

*Lifting
Pulling
Hoisting*

Toll Free Number: 1-800-394-1139

www.bloommfg.com

"Custom Engineered Solutions"

1443 220th Street., Independence, Iowa 50644 • FAX: 319-827-1140 • PHONE: 319-827-1139 RV7/2020

BLOOM™ WINCH



"Quality Since 1910"

Series 1000C Galv Model Selection from Performance Data

MODEL EXAMPLE: 10-E-L8-C-20-LP-GALV

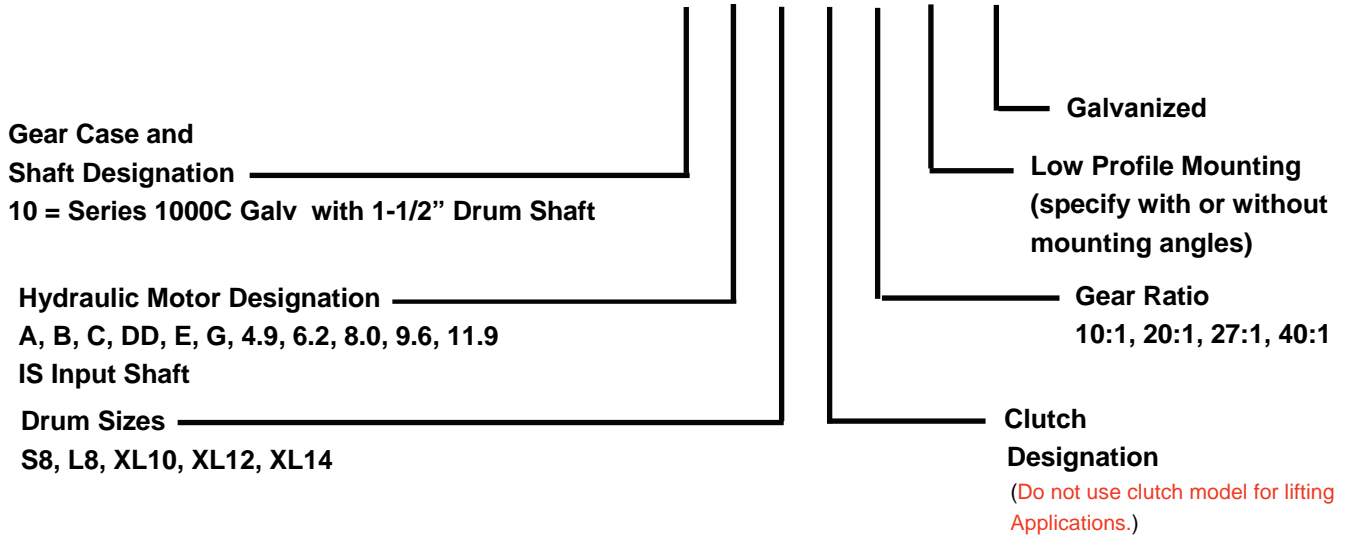

DRUM CAPACITY

CABLE DIAMETER (IN.)	1/4	5/16	3/8	7/16	1/2
DRUM "S8" CAPACITY (FT.)	260	160	105	75	55
DRUM "L8" CAPACITY (FT.)	390	240	160	110	80
DRUM "XL10" CAPACITY (FT.)	840	550	340	250	170
DRUM "XL12" CAPACITY (FT.)	1320	840	580	380	280
DRUM "XL14" CAPACITY (FT.)	1900	1180	760	540	410

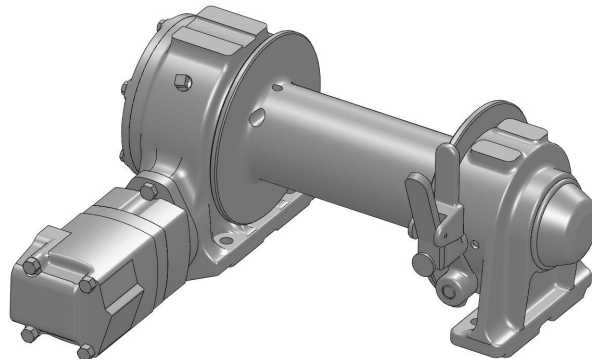

BLOOM™ WINCH



Series 1000C Galv

"Quality Since 1910"

Model Selection from Performance Data

10:1 RATIO (optional)

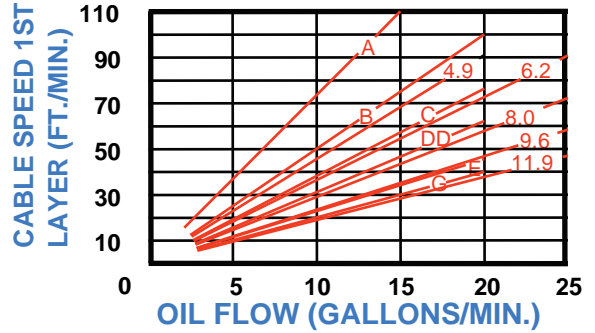
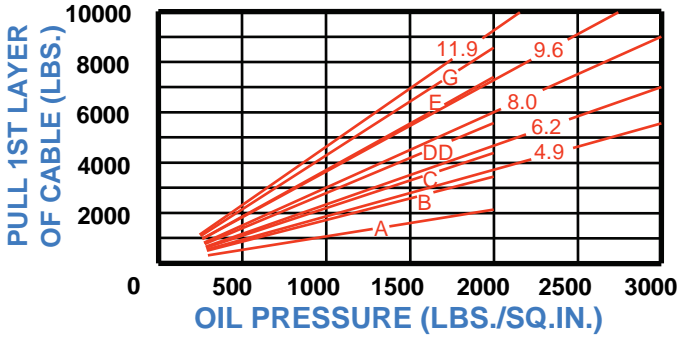

20:1 RATIO (standard)

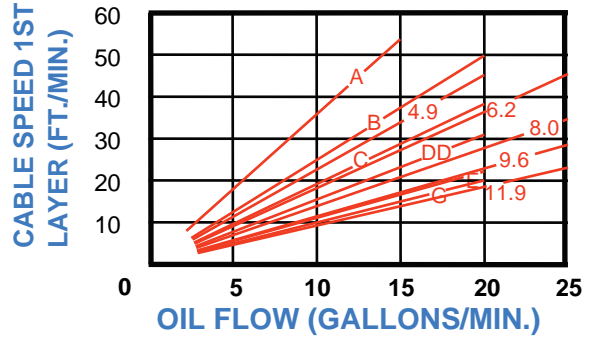
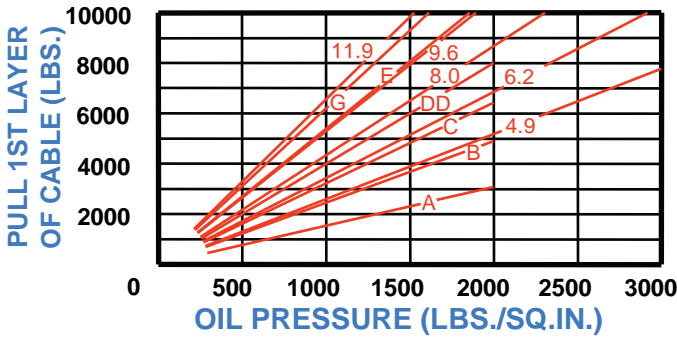

27:1 RATIO (optional)

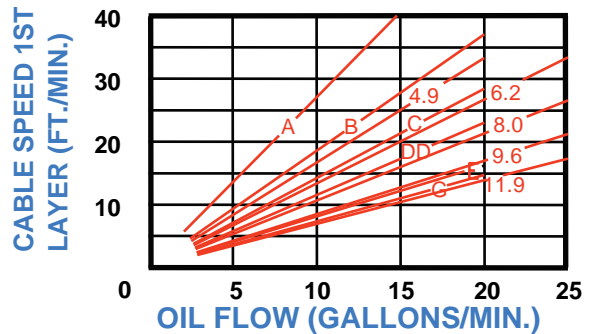
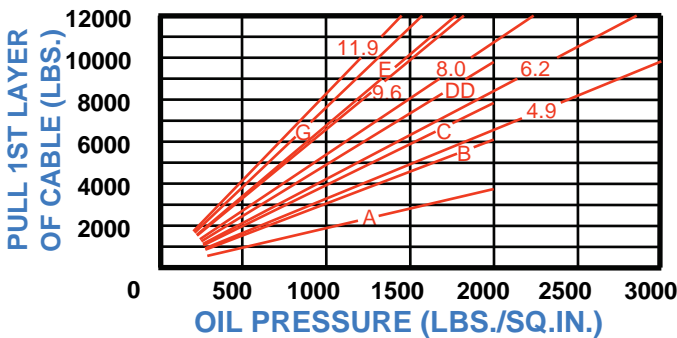

40:1 RATIO (optional)

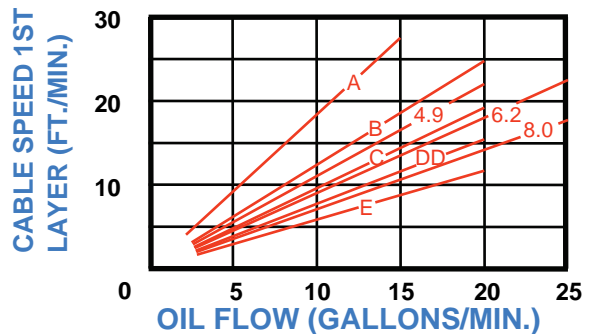
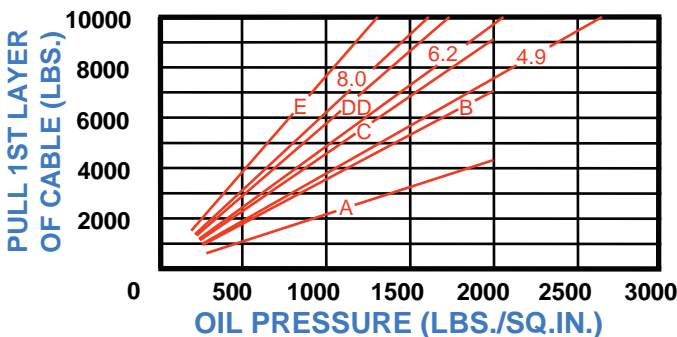



"Quality Since 1910"

BLOOM™ WINCH

Dimensional Drawings

Series 1000C Galv With S8 and L8
Drum Base Mount Model - Clutch Drive

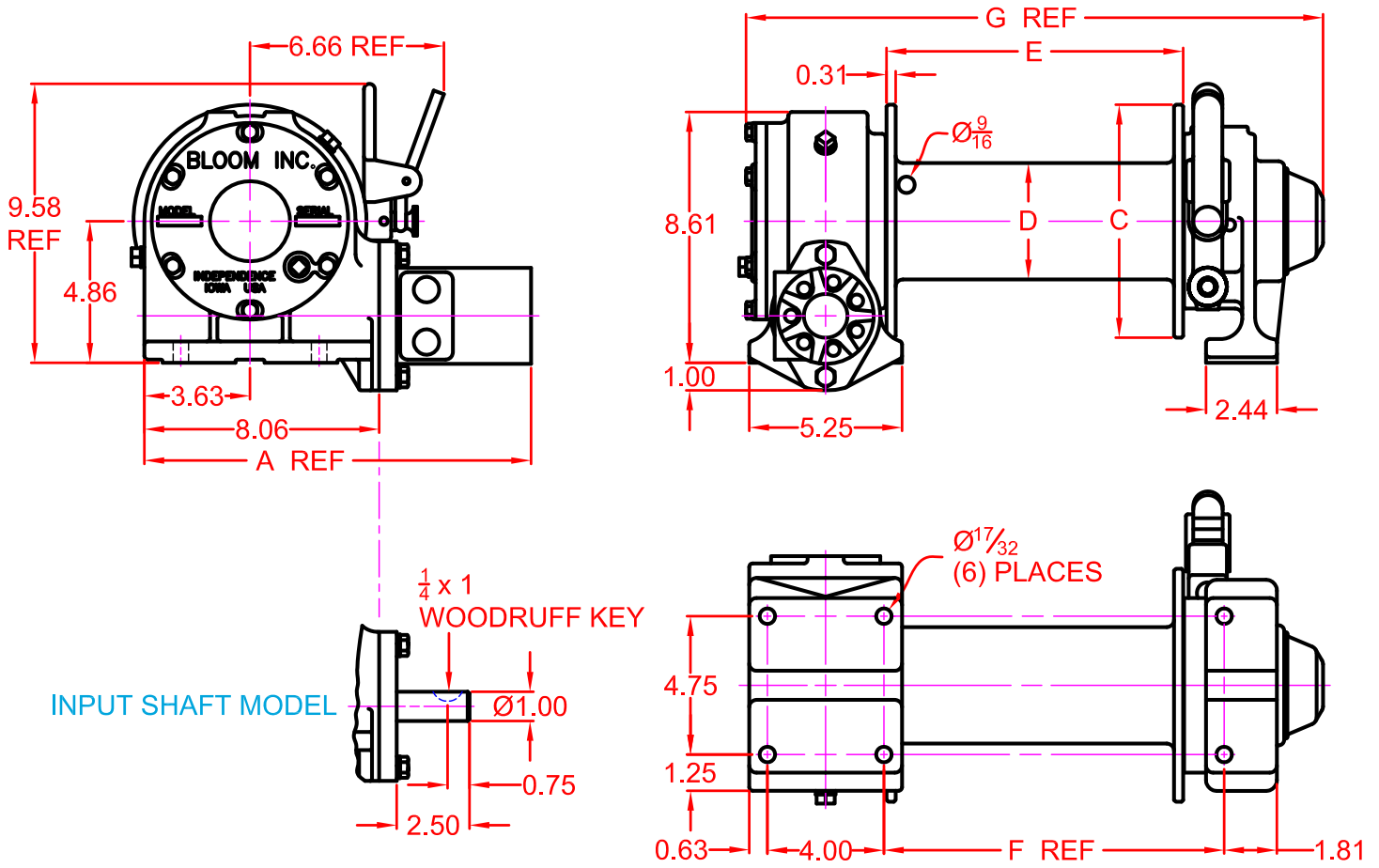

MOTOR DESIGNATION	A	B	C	DD	E	G	4.9	6.2	8.0	9.6	11.9
A DIMENSION	13.28	13.43	13.55	13.68	13.90	14.03	15.32	15.50	15.75	15.75	16.02
DRUM DESIGNATION	WINCH DIMENSION										
	C	D	E	F	G						
	S8	8	4	7.19	8.69	16.82					
L8	8	4	10.19	11.69	19.82						



BLOOM™ WINCH

Dimensional Drawings

“Quality Since
1910”

Series 1000C Galv With S8 and L8
Drum Low Profile Model - Clutch Drive

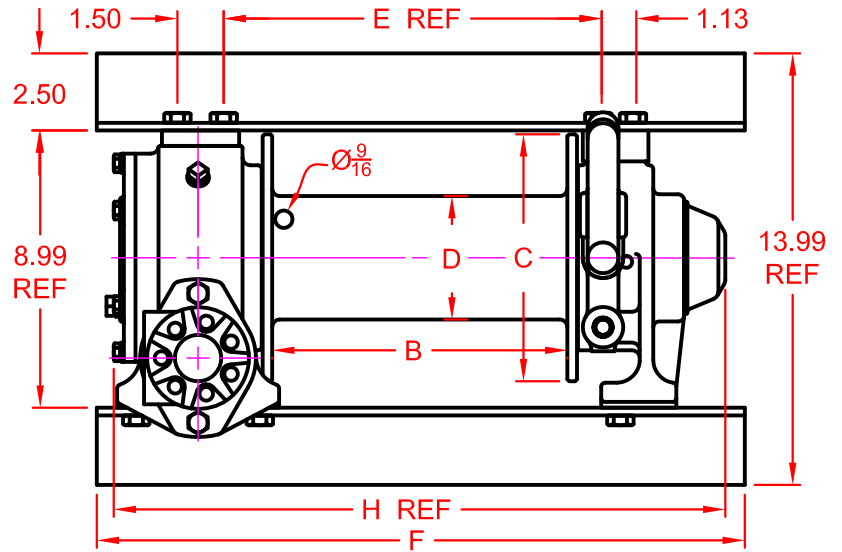
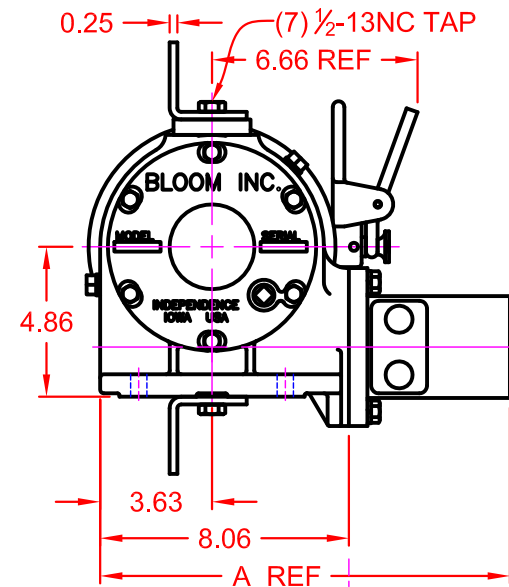

INPUT SHAFT MODEL

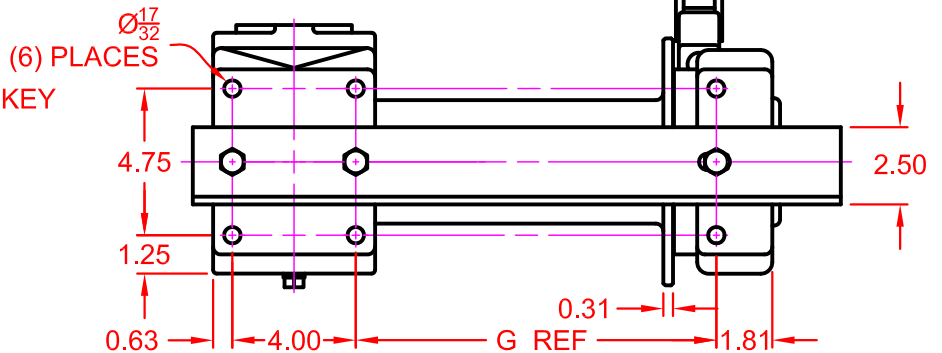
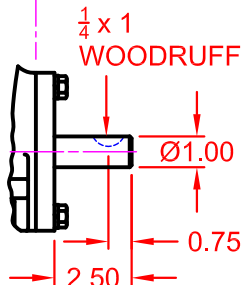

MOTOR DESIGNATION	A	B	C	DD	E	G	4.9	6.2	8.0	9.6	11.9
A DIMENSION	13.28	13.43	13.55	13.68	13.90	14.03	15.32	15.50	15.75	15.75	16.02

DRUM DESIGNATION	WINCH DIMENSION						
	B	C	D	E	F	G	H
S8	6.56	8	4	9.25	18	8.69	16.82
L8	9.56	8	4	12.25	21	11.69	19.82



“Quality Since
1910”

BLOOM™ WINCH

Dimensional Drawings

Series 1000C Galv With XL10, XL12 and XL14
Drum Base Mount Model - Clutch Drive

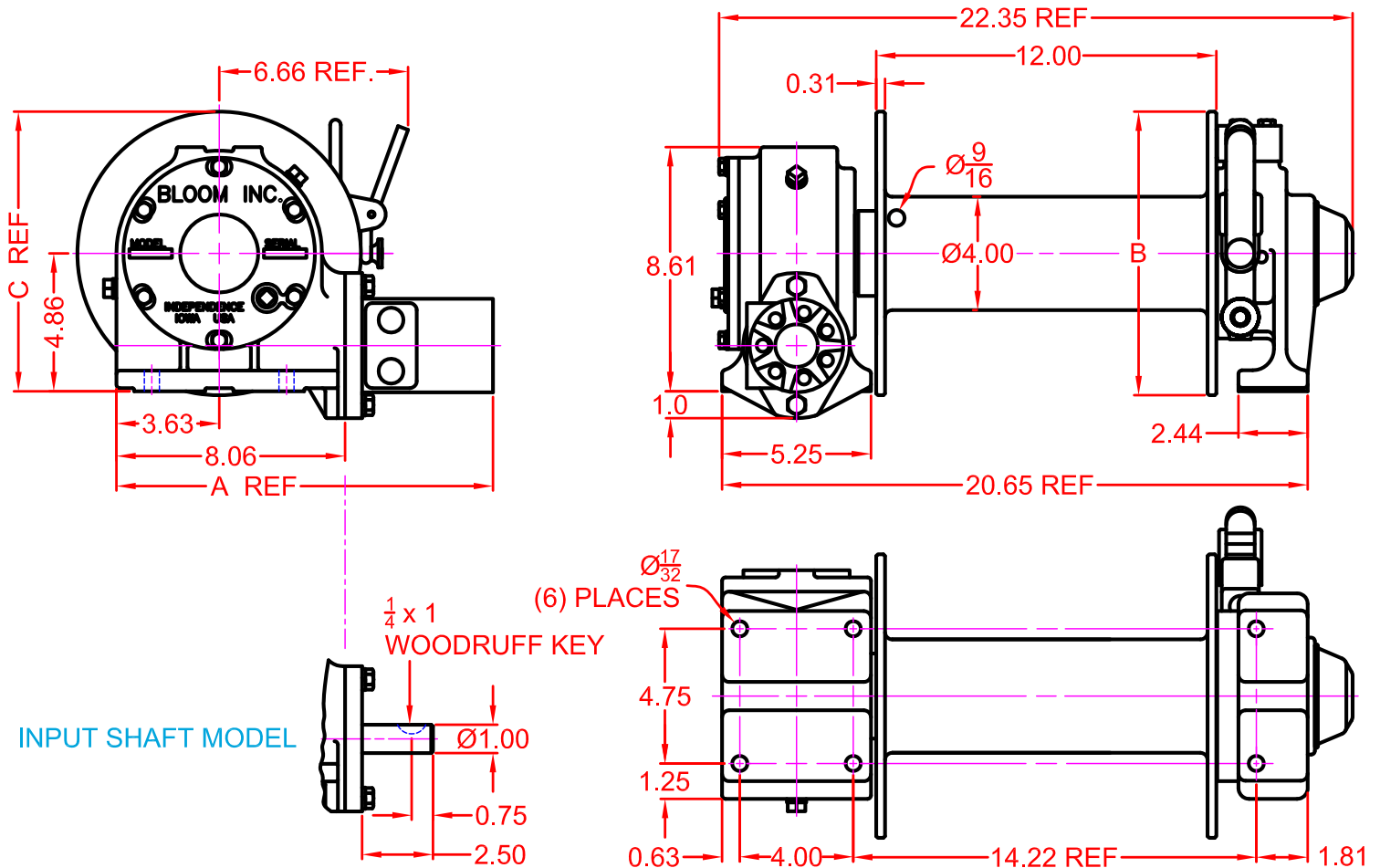

MOTOR DESIGNATION	A	B	C	DD	E	G	4.9	6.2	8.0	9.6	11.9
A DIMENSION	13.28	13.43	13.55	13.68	13.90	14.03	15.32	15.50	15.75	15.75	16.02
DRUM DESIGNATION	XL10			XL12			XL14				
B DIMENSION	10			12			14				
C DIMENSION	9.86			10.86			11.86				

BLOOM™ WINCH

Correct choice of Directional Control Valves for Bloom Winches

Tandem Center Spool Valve – Work Ports are **blocked** in neutral position

Use on all winches that use motor only to hold load.

*Winches require ridged mounting plate.

See owner's manual for information about proper mounting plate thickness or call Bloom Sales Engineer at factory

WARNING!

Goods are not intended for use in the moving or lifting of persons!

The winches described herein are neither designed nor intended for use or application to equipment used in the lifting or moving of persons and it is understood that all such use shall be at the sole risk of the user.

The cable clamps on winches are not designed to hold rated loads. A minimum of 5 wraps of cable must be left on drum barrel to guarantee holding of rated load.

Applications of winch where life would be endangered by any event are not recommended.

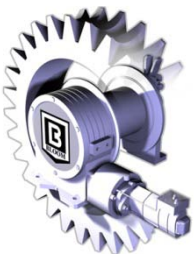

BLOOM Manufacturing LLC

Winch Division

1443 220th Street,, Independence, Iowa 50644

FAX 319-827-1140 PHONE 319-827-1139

www.bloommfg.com

©Copyright 2020 Bloom Mfg. LLC