

BLOOM™ WINCH



*"Quality Since
1910"*

Series 1400 Galv

HYDRAULIC CABLE WINCHES

The rugged construction and versatility of **Series 1400 Galv** makes it adaptable to a wide range of applications. **Series 1400 Galv** direct drive winches are used for lifting or pulling applications such as construction lifting equipment, fishing, other marine craft and cranes.

GALVANIZED

Low Profile or Base Mount Available

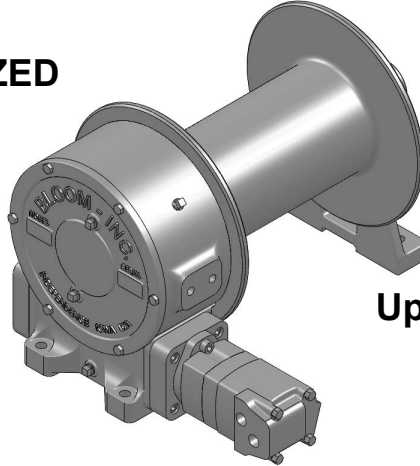

**Up To 15,000 POUNDS
CAPACITY**

Bloom™ Hydraulic Cable Winches – Standard Features

- | | |
|-------------------|--|
| GEAR CASE | - Made of high strength cast iron. Completely sealed for oil enclosed operation and to keep dirt out. |
| WORM SHAFT | - One piece alloy steel hardened and ground for extra durability. Seal on worm allows motor to be removed without draining oil. |
| WORM GEAR | - High tensile aluminum-nickel alloy bronze cast on high strength ductile iron hub. Optimum lead and pressure angles transmit maximum power to the drum. |
| GEAR RATIO | - 25:1 standard & 12.5:1 optional ratios provide optimum efficiency in power and speed. |
| BEARINGS | - Worm gear and worm shaft run on tapered roller bearings. Outer end housing has a grease zerk for lubricating the bronze bushing. |
| DRUM SHAFT | - 2-1/4" diameter heat-treated alloy steel minimum tensile strength 150,000 psi. |
| CABLE DRUM | - Tough all steel construction resists breakage or warping. |

CAUTION:

This winch model does not include any kind of holding brake. If your application requires a holding brake choose **Lift-Safe® winch** series LS14K with hydraulic fail-safe brakes.



www.bloommfg.com

BLOOM
Manufacturing LLC
Winch Division

"Custom Engineered Solutions"

*Lifting
Pulling
Hoisting*

Toll Free Number: 1-800-394-1139

1443 220th Street,, Independence, Iowa 50644 • FAX: 319-827-1140 • PHONE: 319-827-1139

RV7/2020

BLOOM™ WINCH



"Quality Since
1910"

Series 1400 Galv Model Selection from Performance Data

MODEL EXAMPLE: 14-6.2-L14-RH-25-LP-GALV

14 = Series 1400 Galv
with 2-1/4" Drum Shaft

Hydraulic Motor Designation
6.2, 8.0, 9.6, 11.9, 14.9, 18.6

Drum Designation
S14 & L14

Galvanized

Low Profile
Mounting
(mounting angles
not included)

Gear Ratio
12.5:1, 25:1

Hydraulic Motor
Position (R.H. or L.H.)

DRUM CAPACITY

CABLE DIAMETER (IN.)	5/16	3/8	7/16	1/2	9/16	5/8
DRUM "S14" CAPACITY (FT.)	615	400	300	225	160	115
DRUM "L14" CAPACITY (FT.)	1100	712	517	409	295	200

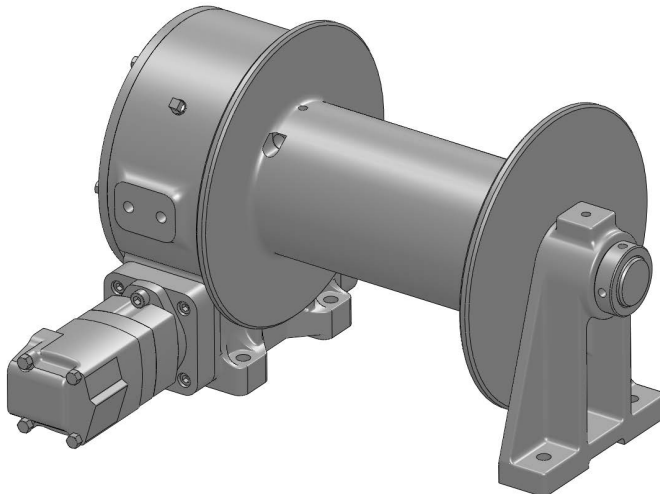

BLOOM™ WINCH



Series 1400 Galv Model Selection from Performance Data

"Quality Since
1910"

12.5:1 RATIO (optional)

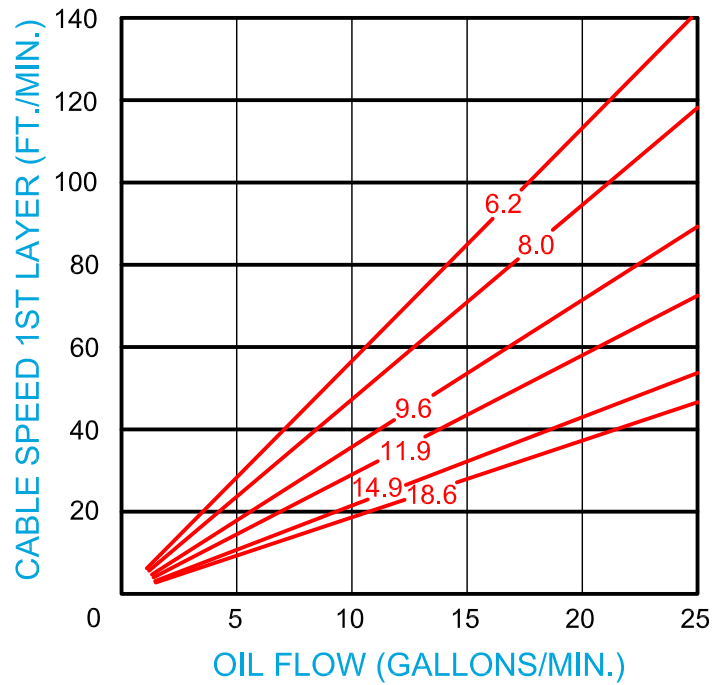
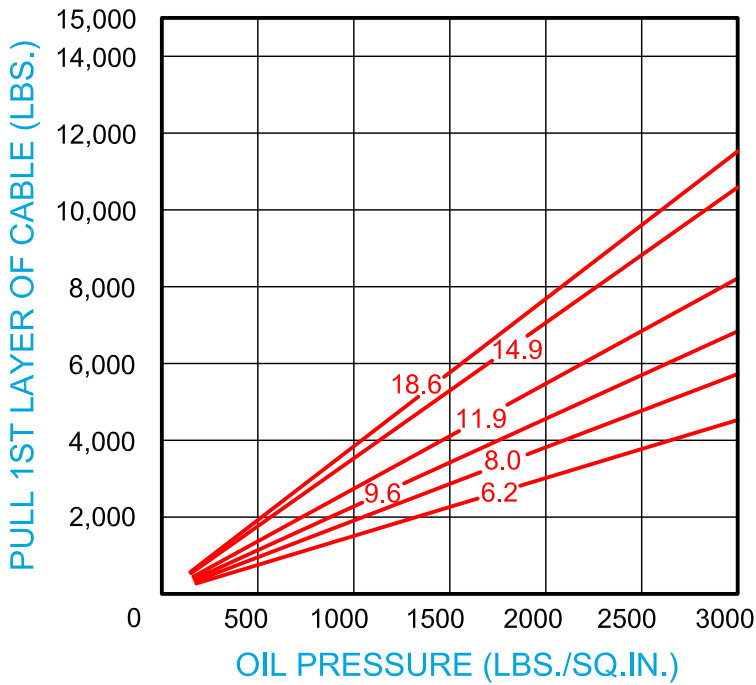

25:1 RATIO (standard)

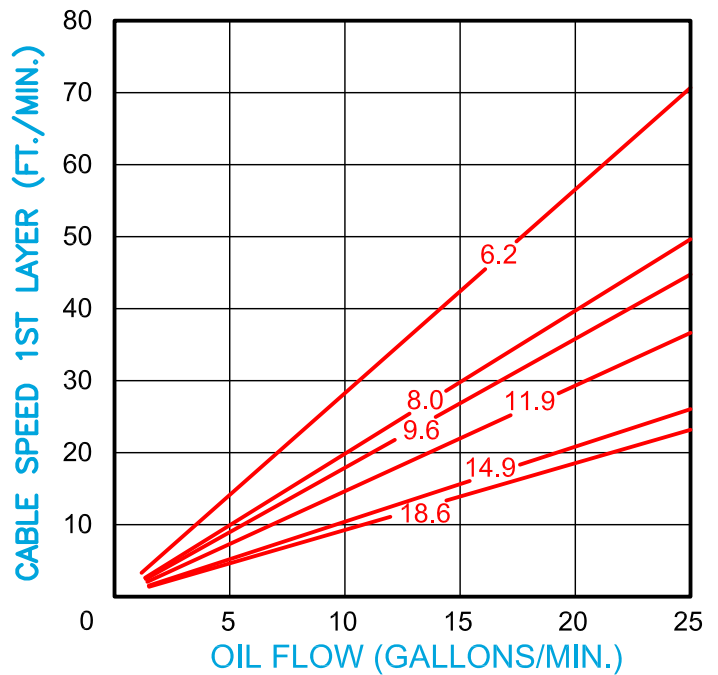
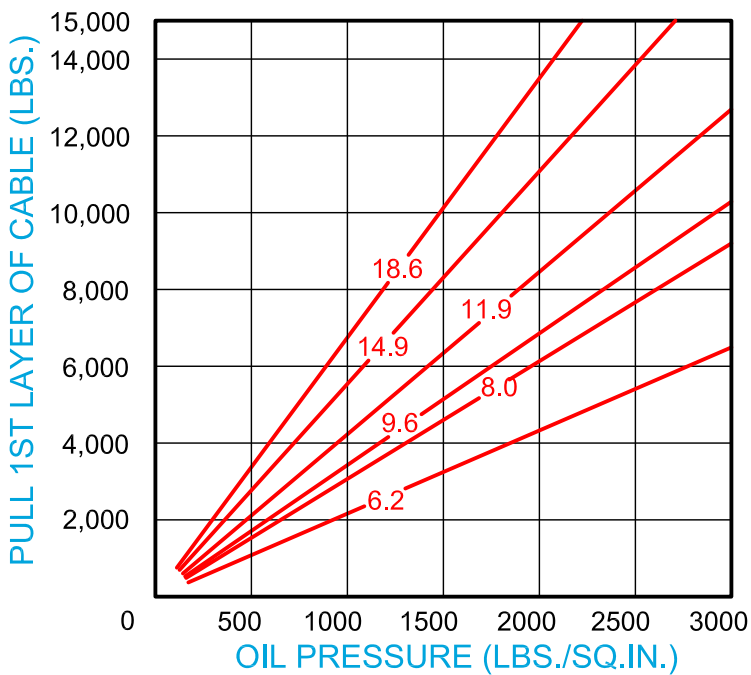



"Quality Since 1910"

BLOOM™ WINCH

Dimensional Drawings

Series 1400 Galv K JH S14 and L14
Drum Base Mount Model - Direct Drive

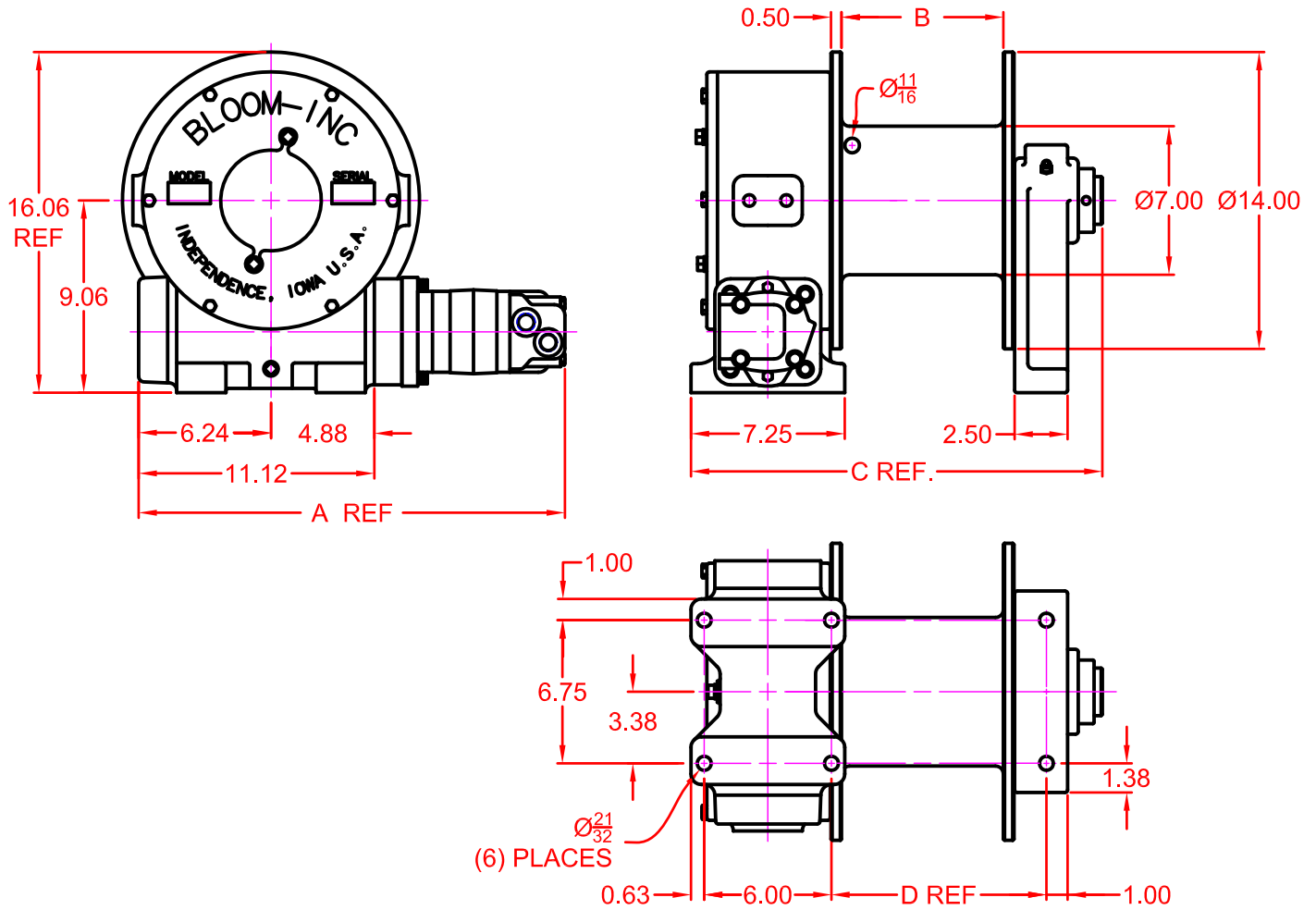

MOTOR DESIGNATION	6.2	9.6	11.9	18.6
A DIMENSION	19.86	20.11	20.38	21.18

DRUM DESIGNATION	B	C	D
S14	7.63	19.40	10.14
L14	13.63	25.46	16.14

CABLE DIAMETER (IN.)	5/16	3/8	7/16	1/2	9/16	5/8
DRUM "S14" CAPACITY (FT.)	615	400	300	225	160	115
DRUM "L14" CAPACITY (FT.)	1100	712	517	409	295	200



"Quality Since 1910"

BLOOM™ WINCH

Dimensional Drawings

Series 1400 Galv K JH 'S14 and L14
Drum Low Profile Model - Direct Drive

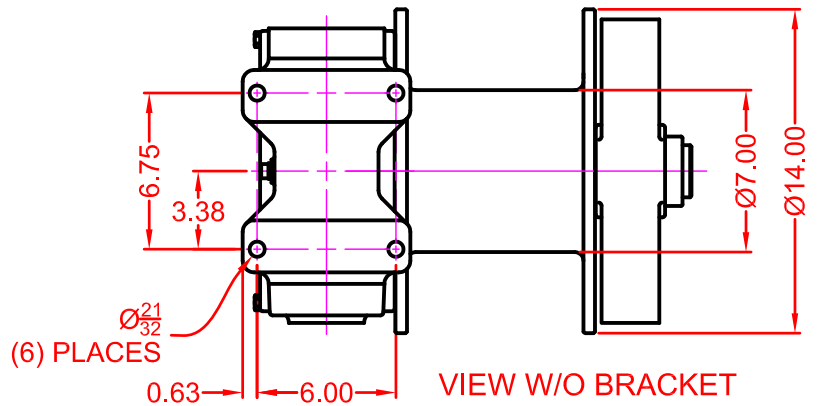
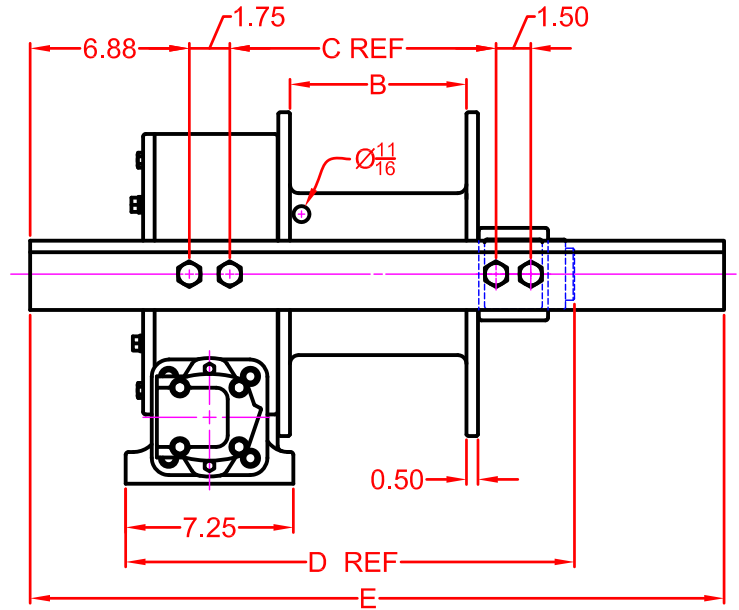
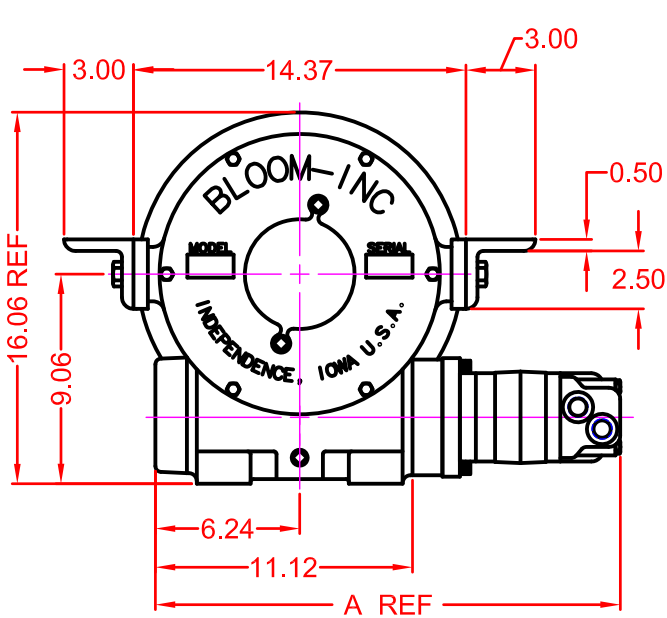

MOTOR DESIGNATION	6.2	9.6	11.9	18.6
A DIMENSION	19.86	20.11	20.38	21.18

DRUM DESIGNATION	B	C	D	E
S14	7.63	11.51	19.40	30
L14	13.63	17.51	25.40	36

CABLE DIAMETER (IN.)	5/16	3/8	7/16	1/2	9/16	5/8
DRUM "S14" CAPACITY (FT.)	615	400	300	225	160	115
DRUM "L14" CAPACITY (FT.)	1100	712	517	409	295	200

BLOOM™ WINCH

Correct choice of Directional Control Valves for Bloom Winches

Tandem Center Spool Valve – Work Ports are **blocked** in neutral position

Use on all winches that use motor only to hold load.

*Winches require ridged mounting plate.
See owner's manual for information about proper mounting plate thickness or call Bloom Sales Engineer at factory

WARNING!

Goods are not intended for use in the moving or lifting of persons!

The winches described herein are neither designed nor intended for use or application to equipment used in the lifting or moving of persons and it is understood that all such use shall be at the sole risk of the user.

The cable clamps on winches are not designed to hold rated loads. A minimum of 5 wraps of cable must be left on drum barrel to guarantee holding of rated load.

Applications of winch where life would be endangered by any event are not recommended.



BLOOM Manufacturing LLC **Winch Division**

1443 220th Street,, Independence, Iowa 50644

FAX 319-827-1140 PHONE 319-827-1139

www.bloommfg.com

©Copyright 2020 Bloom Mfg. LLC