

LIFT-SAFE®



Series LS16K Galv Hydraulic Cable Winches

"Quality Since
1910"

Up To 20,000 POUNDS
CAPACITY

Lift-Safe® hydraulic winches are specifically designed for lifting applications and optimum load control. Engineered for enhanced safety with redundant braking systems, and available in a variety of configurations. Lift-Safe® winches utilize the **DUET-SAFE® Double Action Braking System** to provide both static and dynamic braking. Lift-Safe® winches offer increased operational flexibility, and superior load control in lifting applications. **Series LS16K Galv** direct drive winches are used for industrial pulling and hoisting applications, fishing boats, marine craft, drill rigs, small cranes, factory material handling and rear load waste handlers.

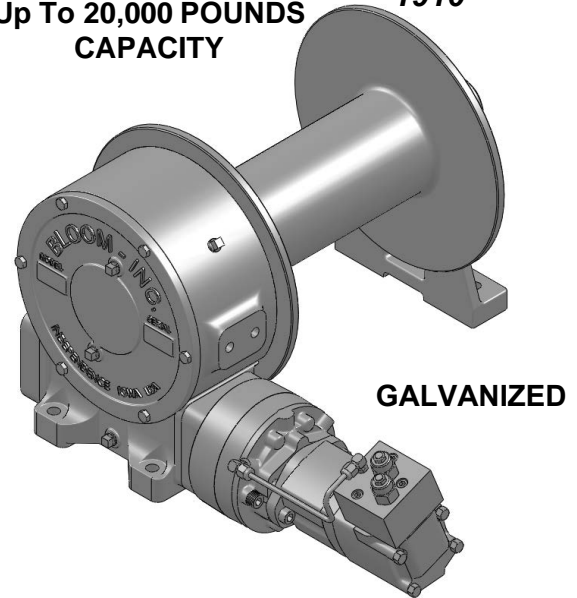

Lift-Safe® Hydraulic Cable Winches – Standard Features

- | | |
|-------------------|--|
| BRAKE | - DUET-SAFE® Double Action Braking System combines a powerful spring applied, hydraulic released brake with a double counter balance brake valve to automatically hold loads when hydraulic pressure is released and control speed during lowering operations. Winch is ideal for high speed lifting and pulling applications or wherever load holding is critical. |
| GEAR CASE | - Made of high strength cast iron. Completely sealed for oil enclosed operation and to keep dirt out. |
| WORM SHAFT | - One piece alloy steel hardened and ground for extra durability. Seal on worm allows brake to be removed without draining oil. |
| WORM GEAR | - High tensile aluminum-nickel alloy bronze cast on high strength ductile iron hub. Optimum lead and pressure angles transmit maximum power to the drum. |
| GEAR RATIO | - 25:1 standard & 12.5:1 optional ratios provide optimum efficiency in power and speed. |
| BEARINGS | - Worm gear and worm shaft run on tapered roller bearings. Outer end housing has a grease zerk for lubricating the bronze bushing. |
| DRUM SHAFT | - 2-1/4" diameter heat-treated alloy steel minimum tensile strength 150,000 psi. |
| CABLE DRUM | - Tough all steel construction resists breakage or warping. |



BLOOM

Manufacturing Inc.

Winch Division

Lifting
Pulling
Hoisting

Toll Free Number: 1-800-394-1139

www.bloommfg.com

"Custom Engineered Solutions"

1443 220th Street,, Independence, Iowa 50644 • FAX: 319-827-1140 • PHONE: 319-827-1139

LIFT-SAFE®



"Quality Since 1910"

Series LS16K Galv Model Selection from Performance Data

MODEL EXAMPLE: LS16K-6.2M-L145-RH-25-LP-GALV

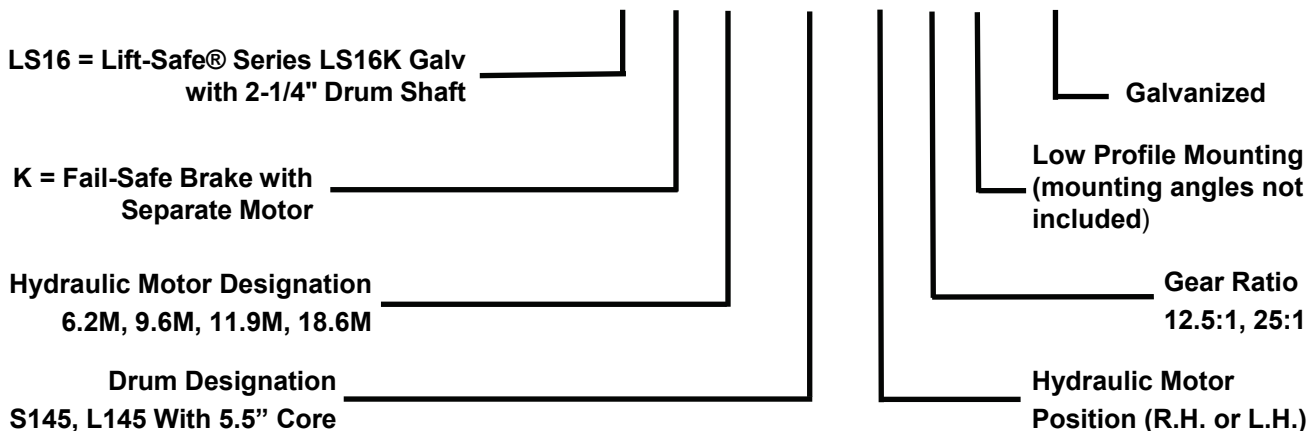

DRUM CAPACITY

CABLE DIAMETER (IN.)	5/16	3/8	7/16	1/2	9/16	5/8
DRUM "S145" CAPACITY (FT.)	674	465	305	234	170	126
DRUM "L145" CAPACITY (FT.)	1214	842	662	425	318	303

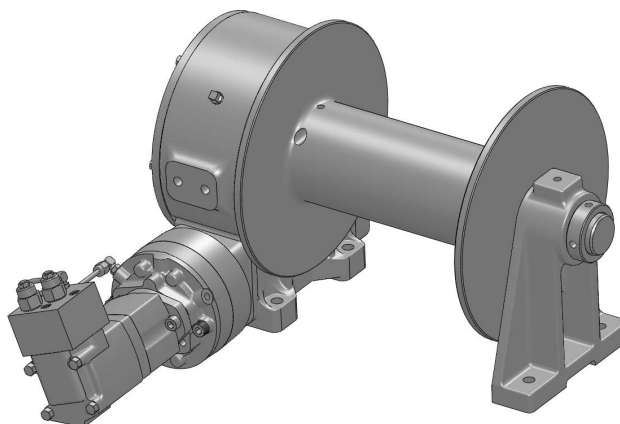

Lift Safe® Cable Winches

Series LS16K Galv W/ 5.50" Core



"Quality Since 1910"

With Hydraulic Fail-safe Brake
Model Selection from Performance Data

12.5:1 RATIO (optional)

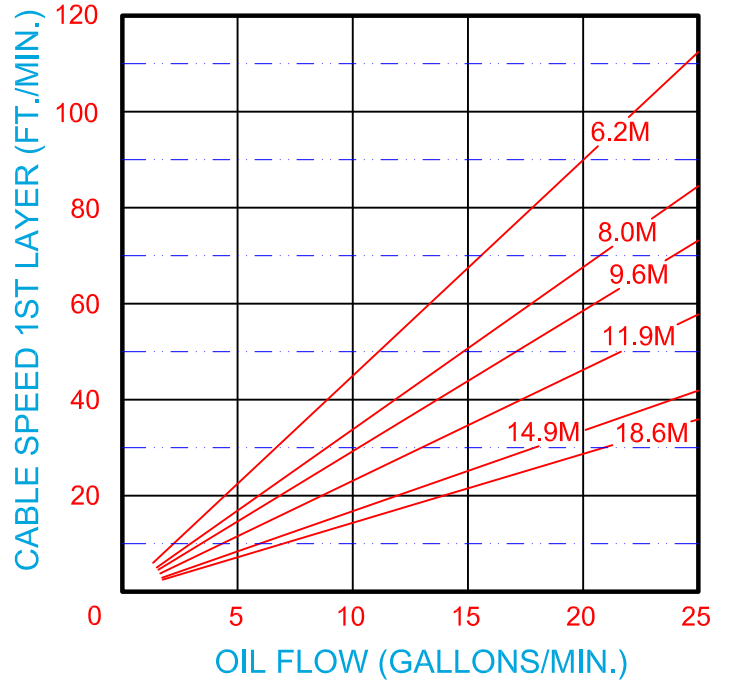
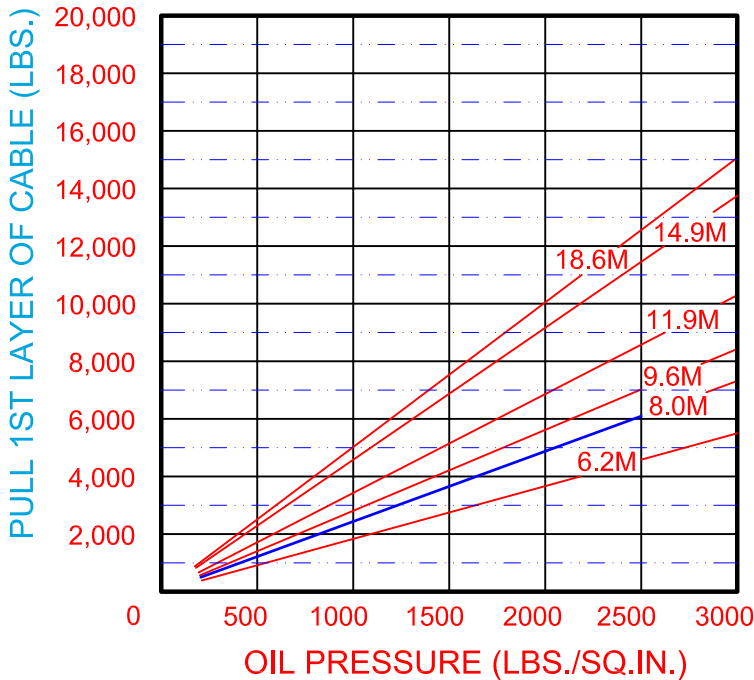

25:1 RATIO (standard)

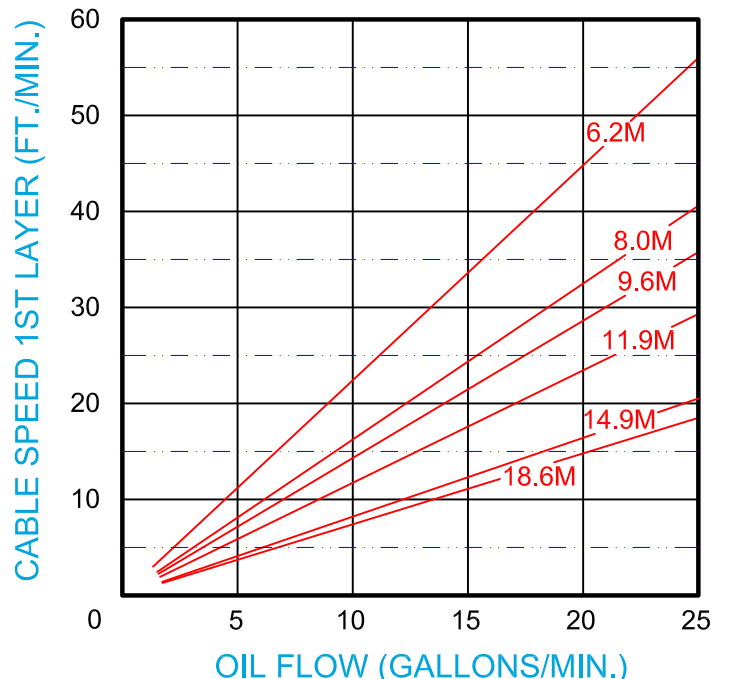
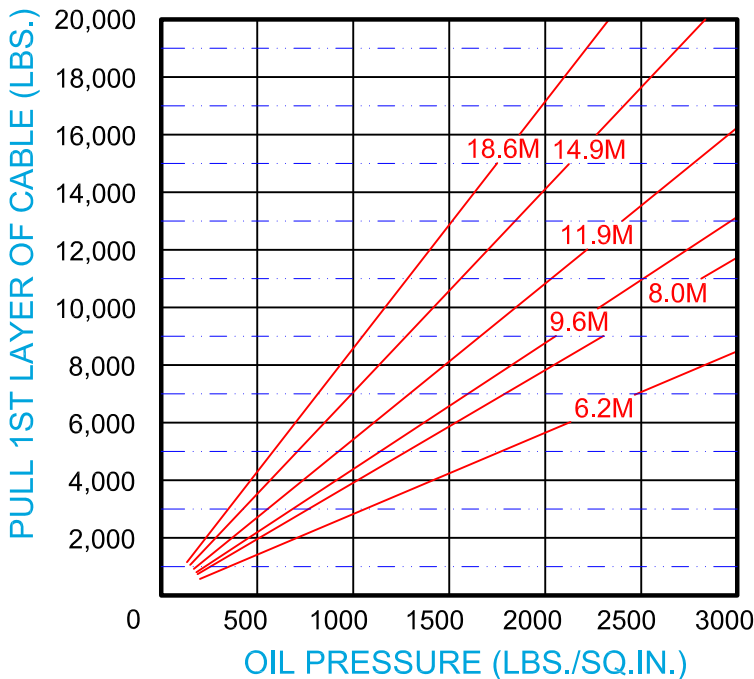

Dimensional Drawings

Series LS16K Galv W/ 5.50" Core
Base Mount Model - Direct Drive

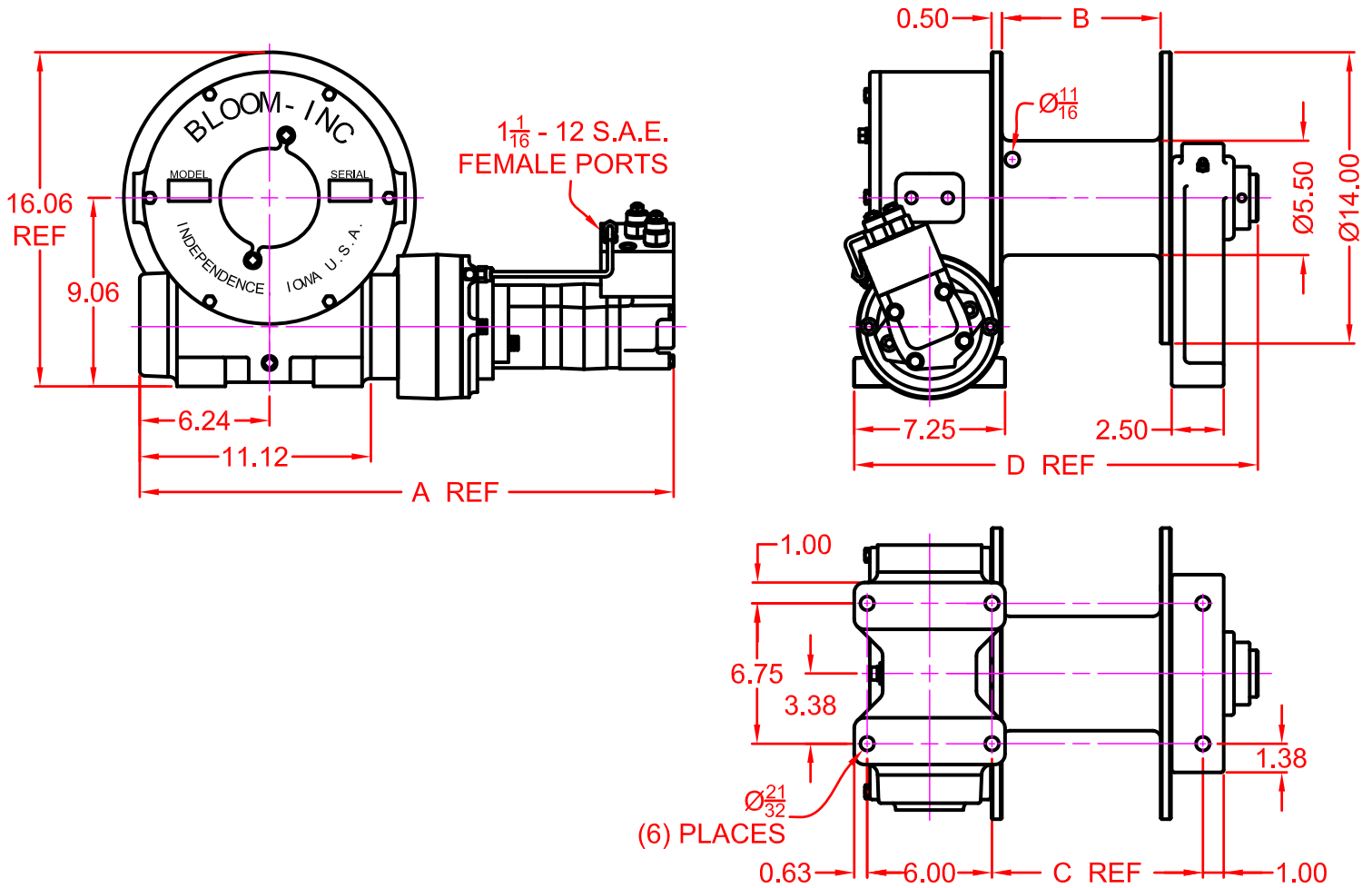

MOTOR DESIGNATION	6.2M	8.0M	9.6M	11.9M	18.6M
A DIMENSION	24.42	24.67	24.67	24.94	25.74

WINCH DESIGNATION	S145		L145		
B DIMENSION	7.63		13.63		
C DIMENSION	10.14		16.14		
D DIMENSION	19.40		25.40		

Dimensional Drawings

Series LS16K Galv W/ 5.50" Core
Low Profile Model - Direct Drive

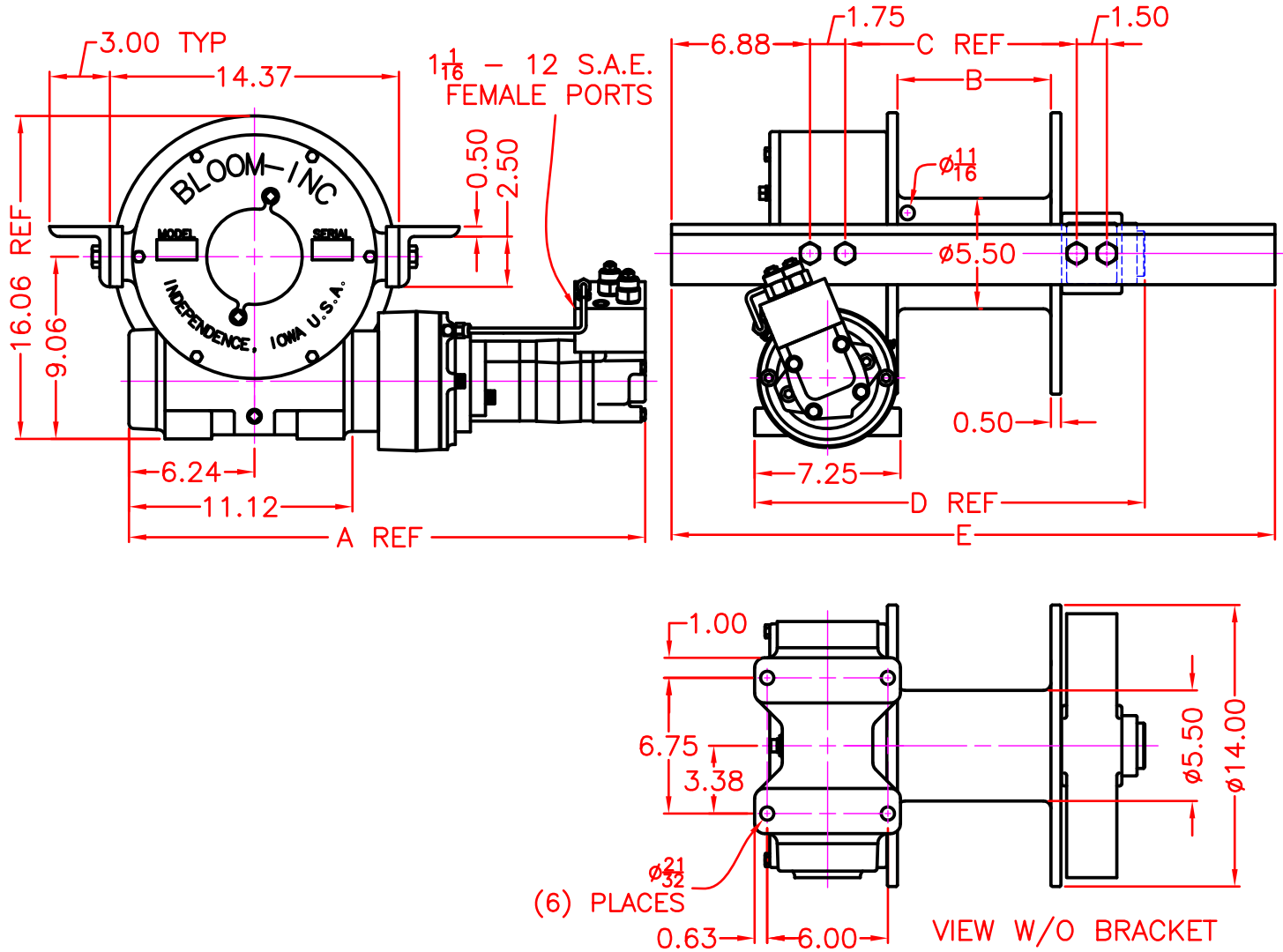

MOTOR DESIGNATION	6.2M	9.6M	11.9M	18.6M
A DIMENSION	24.42	24.67	24.94	24.74
DRUM DESIGNATION	B	C	D	E
S145	7.63	11.51	19.40	30
L145	13.63	17.51	25.40	36

LIFT-SAFE®

Correct choice of Directional Control Valves for Lift-Safe® Winches

All **Lift-Safe®** Winches require a **Motor Spool Control Valve**.

That is the valve's work ports are **open** to tank in neutral position.

*Winches require ridged mounting plate.
See owner's manual for information about proper mounting plate thickness or call Bloom Sales Engineer at factory

WARNING!

Goods are not intended for use in the moving or lifting of persons!

The winches described herein are neither designed nor intended for use or application to equipment used in the lifting or moving of persons and it is understood that all such use shall be at the sole risk of the user.

The cable clamps on winches are not designed to hold rated loads. A minimum of 5 wraps of cable must be left on drum barrel to guarantee holding of rated load.

Applications of winch where life would be endangered by any event are not recommended.

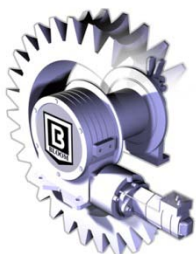

BLOOM Manufacturing Inc. **Winch Division**

1443 220th Street,, Independence, Iowa 50644

FAX 319-827-1140 PHONE 319-827-1139