



Disassembly Instructions 2100KC, 2200KC & 2300KC Series Planetary Winches

Refer to parts breakdown drawing

- 1) Drain oil from gear case.
- 2) Loosen set screws (Ref. 39) in locking collar, then remove locking collar (Ref. 40) from shaft.
- 3) Remove clutch housing assembly (Ref. 92) from drum shaft (Ref. 24). If replacement of bushing is required, press bronze bushing out of end housing and remove grease zerk.
- 4) Remove clutch dog (Ref. 27) & Keys (Ref. 25) from drum shaft (Ref. 24)
- 5) Remove drum (Ref. 16), keys (Ref. 25) and spacer (Ref. 15) from drum shaft (Ref. 24).
- 6) Remove cover (Ref. 13) from gear case (Ref. 11).
- 7) Loosen nut on hydraulic hose fitting (Ref. 90).
- 8) Remove motor (Ref. 2) from fail-safe brake (Ref. 5).
- 9) Remove fail-safe brake (Ref. 5) from planetary gear box (Ref. 8)
- 10) Carefully remove planetary gear box (Ref. 8) from gear case (Ref. 11).
- 11) Remove retaining rings (Ref. 12 & 95) from drum shaft (Ref. 24).
- 12) Remove drum shaft (Ref. 24) from gear case (Ref. 11).
- 13) Remove ball bearings (Ref. 10) from gear case (Ref. 11).

Assembly Instructions 2100KC, 2200KC & 2300KC Series Planetary Winches

Refer to parts breakdown drawing

- 1) Clean gear case and all parts thoroughly, inspect all parts and replace if worn or scored.
- 2) Install ball bearings (Ref. 10) into gear case (Ref. 11).
- 3) Install drum shaft (Ref. 24) onto gear case and install retaining rings (Ref. 12 & 95) onto drum shaft (Ref. 24)
- 4) Use silicon (form a gasket) onto gear case (planetary gear box side) (Ref. 11).
Then carefully install planetary gear box (Ref. 8) onto gear case (Ref. 11) with (16) 3/8"-24NF x 2" Hex Head Cap Screws (Ref. 22). (being sure tighten the screws evenly)
- 5) If removed, install oil seal (Ref. 15) onto cover (Ref. 14).
- 6) Use silicon (form a gasket) onto gear case (Ref. 11) (gear case cover side).
Then install cover (Ref. 13) onto gear case (Ref. 11) with (6) 3/8"-16UNC x 1" Socket Head Cap Screws (Ref. 20).
(being sure tighten the screws evenly)
- 7) Install spacer (Ref. 15) onto drum shaft (Ref. 24).
- 8) Grease drum shaft (Ref. 24) with multi-purpose lithium grease or equivalent and install drum (Ref. 16)
Install keys (Ref. 25) in drum shaft (Ref. 24). Slide clutch dog (Ref. 27) onto drum shaft.
- 9) If bronze bushing in end housing has been removed, press in new bushing. Hone inside diameter of bushing to 2.252 - 2.253". Place drill in grease zerk hole and drill a 1/4" hole through bushing. Install grease zerk.
- 10) Install clutch housing and clutch handle assembly on drum shaft. Locate clutch handle pins in clutch dog groove.
Place clutch lever pin in "engaged" position on clutch position plate. Install spring and friction block into end housing. Move clutch housing assembly towards drum so that clutch dog is fully engaged in drum. There should be about 1/16" clearance between friction block housing and drum. Adjust clutch position plate for proper clearance if necessary. Move clutch lever pin to the "disengaged" position and check for sufficient clearance between drum and clutch dog. Place locking collar against end housing and tighten set screws.
- 11) Apply Loctite brand Quickstix 548 flange sealant to planetary flange (Ref. 8) and Fail-Safe Brake flange (Ref. 5).
Apply silicon to Socket Head Cap Screw threads (Ref. 7). Install Fail-Safe Brake onto planetary gear box using Paper Gasket (Ref. 6) and (2) 1/2"-13UNC x 3/4" Socket Head Cap Screws (Ref. 7). Torque to 55 ft-lbs.
Do Not Exceed 50 ft-lbs Torque
- 12) Install motor (Ref. 2) onto Fail-Safe Brake flange (Ref. 5) with (2) 1/2"-13UNC x 1-1/4" HHCS, Plastic Gasket (Ref. 4), and lock washers.
- 13) If removed, align both ends of hydraulic tube (Ref. 91) to the ports (Ref. 90). Push hydraulic tube (Ref. 91) into installed fitting body (Ref. 90) on motor (Ref. 2) and fail-safe brake (Ref. 8) until it stops. Fasten nuts and tapered split rings to fittings. Turn nuts hand tight, then with wrench tighten one turn or until rear of tapered split ring is flush with the nut. **Do Not Overtighten**
- 14) Fill gear box with (4) pints (1.9 liters) Bloom ULLTRA-LUBE NO. 601 TRANS-WORM GEAR OIL.

Bloom Manufacturing Inc.

Parts Breakdown

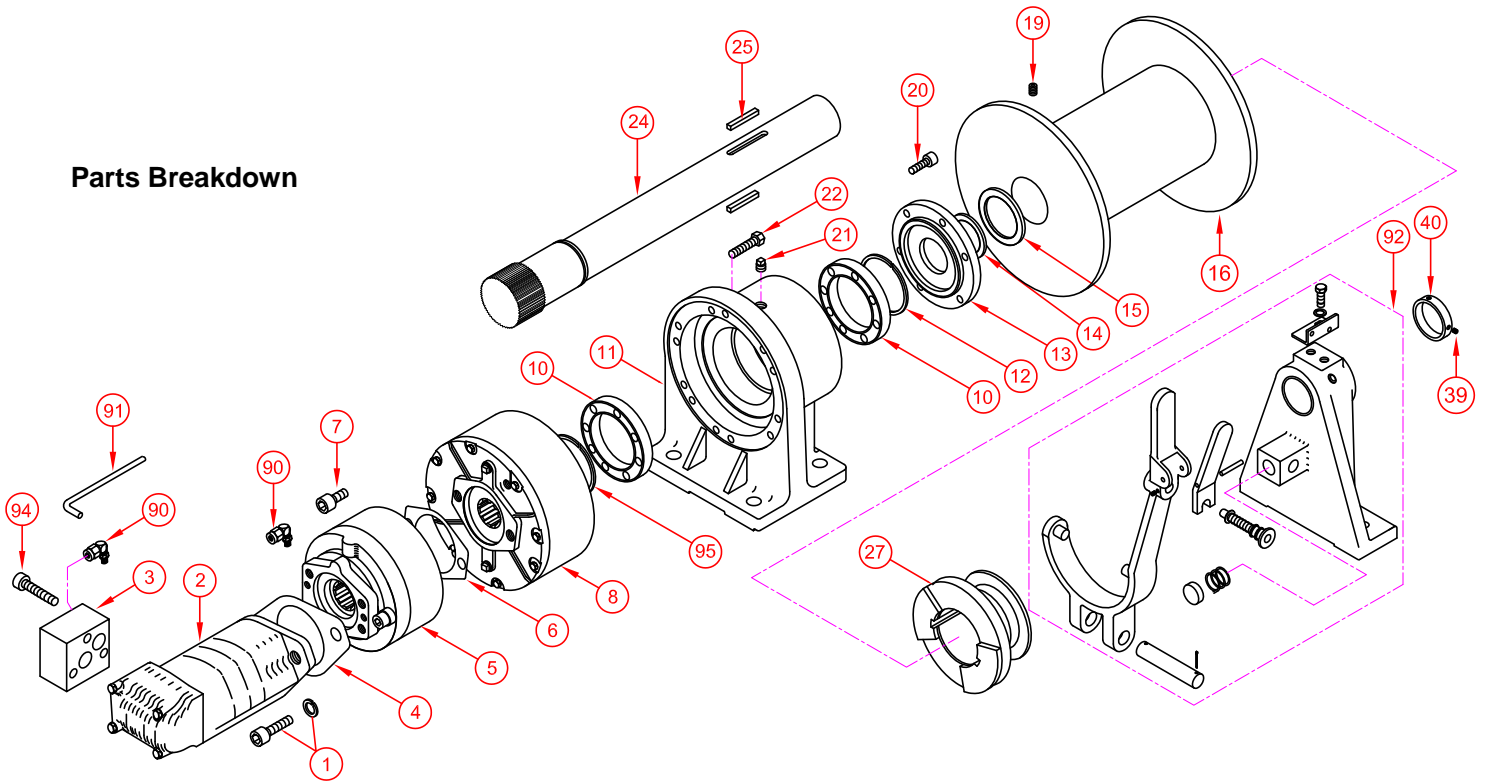

**Hydraulic line assembly
(Ref. 2, 3, 5, 90 & 91)**

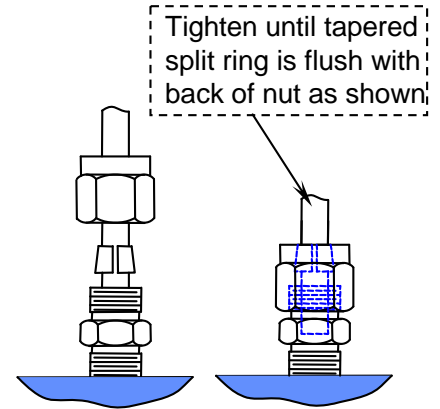
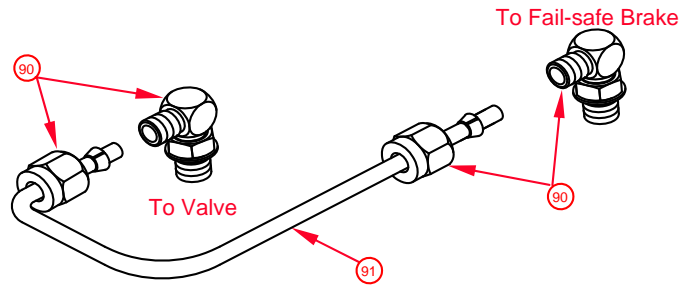

**Shown parts breakdown of
planetary gearbox (Ref. 8)**

