

# BLOOM™ WINCH



"Quality Since  
1910"

## Series 800HC

### HYDRAULIC CABLE WINCHES

The rugged construction and versatility of **Series 800HC** makes it adaptable to a wide range of applications. **Series 800HC** winches are equipped with a sliding clutch to allow free-spooling of the drum for industrial pulling and dragging applications including rear of cab and front mounting on ½ to 1 ½ ton trucks, flat bed trailers, material handling, mining and logging operations, air freight pullers, off road tractors, aboard ships and boats.

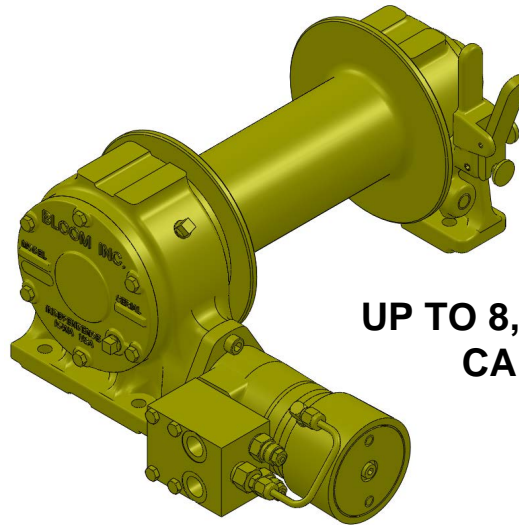

**UP TO 8,000 POUNDS  
CAPACITY**

## Bloom™ Hydraulic Cable Winches – Standard Features

- |                      |  |
|----------------------|--|
| <b>MOTOR-BRAKE</b>   | - <b>DUET-SAFE® Double Action Braking System</b> combines a powerful spring applied, hydraulic released motor-brake with a double counter balance brake valve to automatically hold loads when hydraulic pressure is released and control speed during lowering operations. Winch is ideal for high speed pulling applications or wherever load holding is critical. |
| <b>GEAR CASE</b>     | - Made of high strength cast iron. Completely sealed for oil enclosed operation and to keep dirt out.  |
| <b>WORM SHAFT</b>    | - One piece alloy steel hardened and ground for extra durability. Compact design allows hydraulic motor to be coupled directly to worm.  |
| <b>WORM GEAR</b>     | - High tensile aluminum-nickel alloy bronze. Optimum lead and pressure angles transmit maximum power to the drum.  |
| <b>GEAR RATIO</b>    | - 20:1 standard, 10:1 optional ratios provide optimum efficiency in power and speed.   |
| <b>BEARINGS</b>      | - Worm gear and worm shaft run on tapered roller bearings. Outer end housing has sealed ball bearing.  |
| <b>DRUM SHAFT</b>    | - 1-1/4" diameter heat-treated alloy steel minimum tensile strength 150,000 psi.   |
| <b>CABLE DRUM</b>    | - Tough all steel construction resists breakage or warping.  |
| <b>CLUTCH OPTION</b> | - Series 800HC winches comes equipped with heat-treated dog type clutch to provide free-spooling of the winch drum. Positive lock-in and lock-out.   |



www.bloommfg.com

# BLOOM

Manufacturing Inc.

Winch Division

**"Custom Engineered Solutions"**

**Lifting  
Pulling  
Hoisting**

Toll Free Number: 1-800-394-1139

1443 220<sup>th</sup> Street, Independence, Iowa 50644 • FAX: 319-827-1140 • PHONE: 319-827-1139

# BLOOM™ WINCH



"Quality Since 1910"

## Series 800HC Model Selection from Performance Data

MODEL EXAMPLE: 8H-3.0T-L8-C-10-LP

Gear Case Mounting  
8H = Series 800HC With 1-1/4" Drum Shaft

Low Profile Mounting  
(specify with or without mounting angles)

Hydraulic Motor Designation  
3.0T, 4.0T, 6.2T

Gear Ratio  
10:1, 20:1

Drum Sizes  
S, S8 with 3.5" Core  
L, L8 with 4" Core

Clutch Designation  
(Do not use clutch model for lifting Applications)

### DRUM CAPACITY

CABLE DIAMETER (IN.)	1/4	5/16	3/8	7/16	1/2
DRUM "S" CAPACITY (FT.)	120	70	45	30	25
DRUM "S8" CAPACITY (FT.)	260	160	105	75	55
DRUM "L" CAPACITY (FT.)	175	105	65	45	30
DRUM "L8" CAPACITY (FT.)	390	240	160	110	80

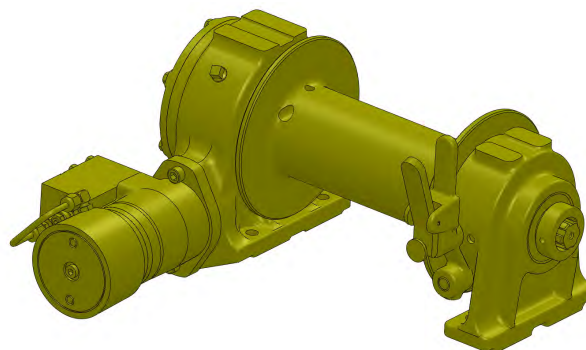



## Series 800HC

### Bloom Hydraulic Cable Winches Model Selection from Performance Data

10:1 RATIO (optional)

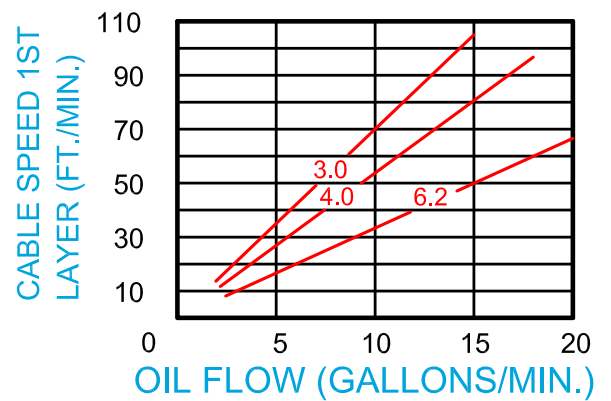
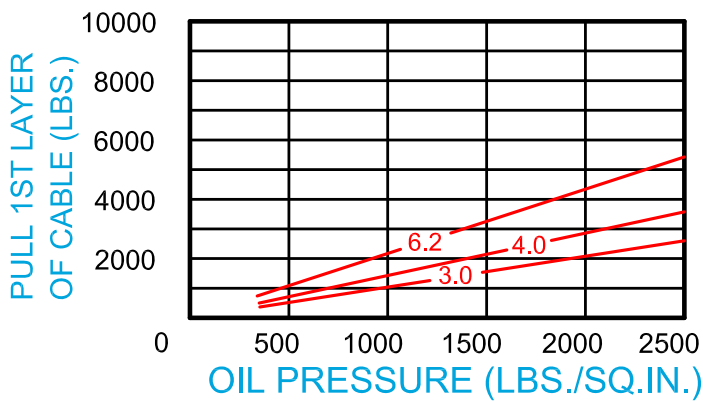

20:1 RATIO (standard)

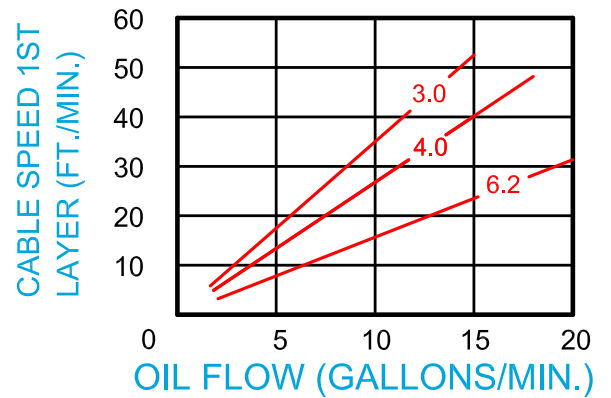
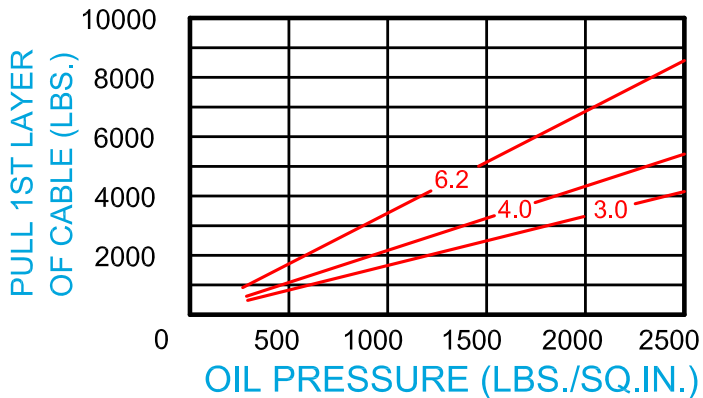



“Quality Since  
1910”

# BLOOM™ WINCH

## Dimensional Drawings

Series 800HC K JH G, S8, L and L8 Drum  
Base Mount Model - Clutch Drive

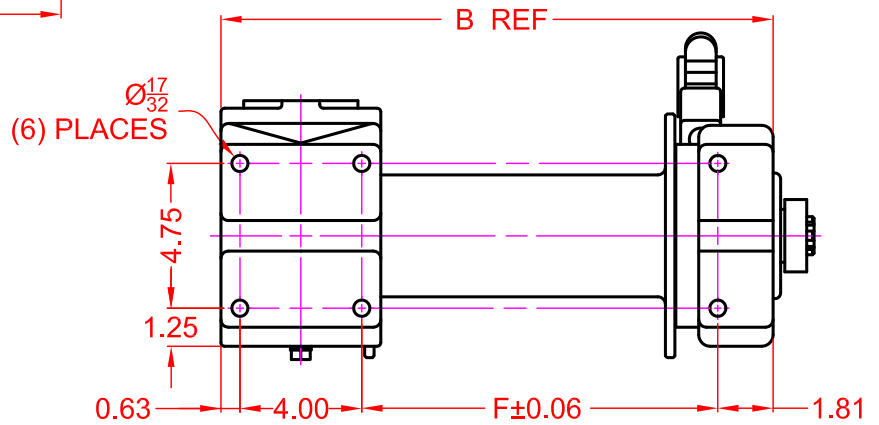
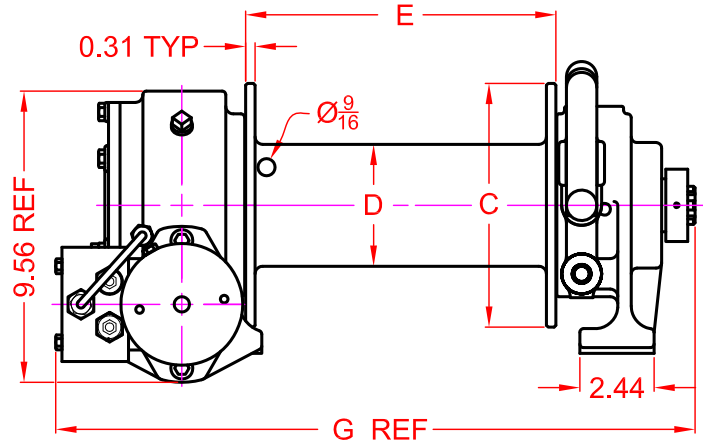
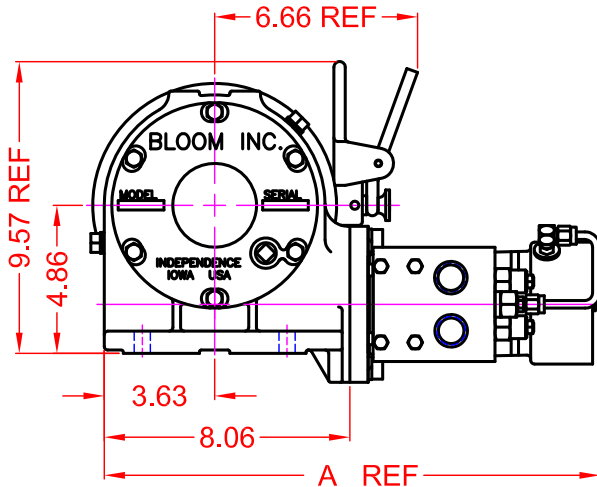

MOTOR DESIGNATION	3.0	4.0	6.2
A DIMENSION	15.91	16.03	16.28

DRUM DESIGNATION	WINCH DIMENSION					
	B	C	D	E	F	G
S	15.12	6	3.50	7.19	8.69	17.98
S8	15.12	8	4	7.19	8.69	17.98
L	18.12	6	3.50	10.19	11.69	20.98
L8	18.12	8	4	10.19	11.69	20.98

# **BLOOM™ WINCH**

## **800HC SERIES MODEL SELECTION**

### **3.0T MOTOR**

8H-3.0T-SC-20  
8H-3.0T-S8C-20  
8H-3.0T-LC-20  
8H-3.0T-L8C-20

### **6.2T MOTOR**

8H-6.2T-SC-20  
8H-6.2T-S8C-20  
8H-6.2T-LC-20  
8H-6.2T-L8C-20

# BLOOM™ WINCH

## Correct choice of Directional Control Valves for Bloom Winches

Winches require a **Motor Spool Control Valve**.  
That is the valve's work ports are **open** to tank in neutral position.

\*Winches require ridged mounting plate.  
See owner's manual for information about proper mounting  
plate thickness or call Bloom Sales Engineer at factory.

### **WARNING!**

Goods are not intended for use in the moving or lifting of  
persons!

The winches described herein are neither designed nor intended  
for use or application to equipment used in the lifting or moving of  
persons and it is understood that all such use shall be at the sole  
risk of the user.

The cable clamps on winches are not designed to hold rated  
loads. A minimum of 5 wraps of cable must be left on drum barrel  
to guarantee holding of rated load.

Applications of winch where life would be endangered by any  
event are not recommended.



## **BLOOM Manufacturing Inc.** **Winch Division**

1443 220<sup>th</sup> Street,, Independence, Iowa 50644

FAX 319-827-1140 PHONE 319-827-1139