

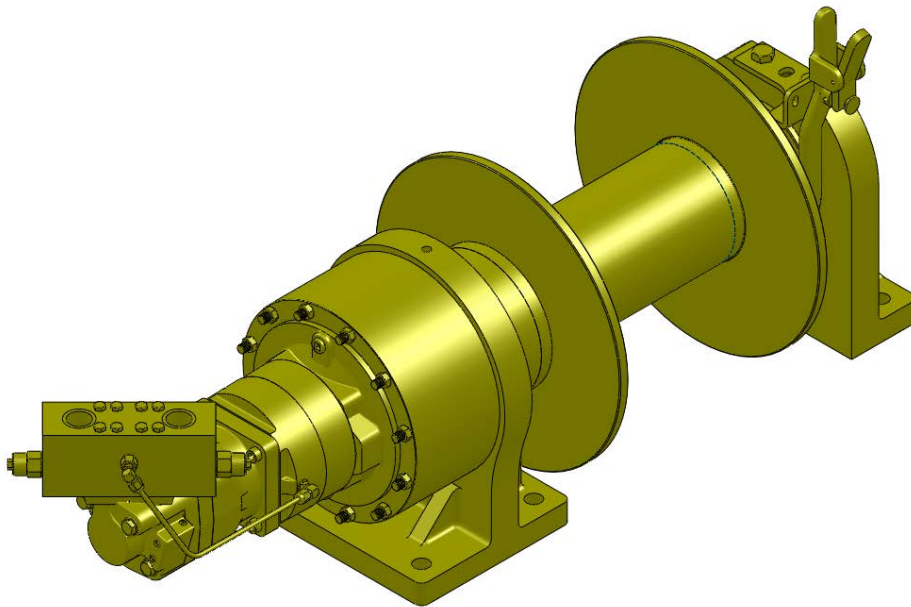

Safety, Warranty, Maintenance & Repair, Installation and Operation Manual

Bloom™ Hydraulic Cable Winch

3000KC, 3200KC, 4000KC & 4200KC Series



All Bloom winches have the model and serial number stamped on the gear support . Please take a few minutes to record these numbers for future use. You will need these numbers for ordering parts or gathering service information from the factory:

Model # _____ Serial # _____

Thank you for your purchase of a quality Bloom product !

THIS MANUAL MUST BE KEPT WITH THE WINCH AT ALL TIMES AND NEW WINCH OPERATORS MUST READ AND UNDERSTAND IT.

Table of Contents

1. General Safety Requirements
2. Warranty
3. Maintenance & Repair
 - (a) Clean and Inspect
 - (b) Oil Change Information
 - (c) Oil Level
 - (d) Recommended Gear Oil
 - (e) Inserts:
 - Assembly (specific model)
 - Disassembly (specific model)
 - Parts List (specific model)
4. Winch Break In
5. Winch Installation
6. Winch Operation
 - (a) Cable Considerations
 - (b) The Importance of a Proper Fleet Angle
 - (c) Wire Rope Anchor & Wrapping
 - (d) Automatic Safety Brakes & Adjustment

Please note that not all of the sections of the Table of Contents apply to each model purchased

Merchandise may not be returned without approval from factory. The customer will be charged for placing the returned goods in salable condition plus a restocking charge of 25%. All returns must be shipped prepaid.

Section 1

General Safety Requirements



THIS SYMBOL MEANS

- Attention!
- Become Alert!
- Your Safety Is Involved



Take Note! This Safety Alert Symbol Found Throughout This Manual Is Used To Call Your Attention To Instructions Involving Your Personal Safety And The Safety Of Others. Failure To Follow These Instructions Can Result In Injury Or Death.

SIGNAL WORDS:

Note the use of the signal words DANGER, WARNING AND CAUTION with the safety messages. The appropriate signal word for each has been selected using the following guidelines:

- **DANGER:** Indicates an imminently hazardous situation that, if not avoided, will result in death or serious injury. This signal word is to be limited to the most extreme situations typically for machine components which, for functional purposes, cannot be guarded.
- **WARNING:** Indicates a potentially hazardous situation that, if not avoided, could result in death or serious injury, and includes hazards that are exposed when guards are removed. It may also be used to alert against unsafe practice.
- **CAUTION:** Indicates a potentially hazardous situation that, if not avoided, may result in minor or moderate injury. It may also be used to alert against unsafe practices.



WARNING

Failure to Heed The Following Warnings May Result In Serious Injury Or Death

- **Bloom winches are not to be used to lift, hoist, or move people.** If your task involves lifting or moving people, you must use the proper equipment, not this winch.
- Cable anchors on Bloom winches are not designed to hold the rated load of the winch. You must keep at least five (5) wraps of cable on the drum to ensure that the cable doesn't come loose. We suggest that the last 5 wraps of cable be painted bright red to serve as a visual warning.
- Stay clear of suspended loads and of cable under tension. A broken cable or dropped load can cause serious injury or death.
- No equipment should be installed, operated, or maintained by any person who has not carefully read all contents of this manual. Serious physical injury or property damage can result from failure to read and apply the instructions contained therein. Therefore, we urge you to read all operating instructions and warnings carefully. If any instruction or warning is not clear, or if you feel you need additional information, please contact Bloom Mfg Inc. This manual should not be understood to prepare you for every possible situation. It is the owner's and user's responsibility to determine the suitability of a product for a particular use. Applicable industry, trade association, federal, state, and local regulations should be reviewed.
- Make sure that all equipment, including the winch and cable, is maintained properly.
- Avoid shock loads. This type of load imposes a strain on the winch many times the actual weight of the load and can cause failure of the cable or of the winch.
- Bloom products are sold on the strict understanding that all products selection is the full responsibility of the purchaser.
- Bloom accepts no liability for the use, misuse or incorrect application of its products.
- Leather gloves should be used when handling winch cable.
- Ensure the correct equipment is obtained and installed for the application.
- Ratings shown in Bloom literature are applicable only to new products.
- Working load limits shown are the maximum load the product is authorized to support under normal environmental conditions. Shock loading and abnormal conditions must be taken into account when selecting products.
- In general, products displayed in Bloom literature are used as parts of a system. As a result, we can only recommend within the working load limits, or other stated limitations, the use of products for this purpose.
- Working load limits or safety factors for each Bloom product may be affected by wear, misuse or environmental conditions. Regular inspection must be conducted to ensure the equipment continues to meet the published standards.

If you have questions not answered in this manual or require additional copies or the manual is damaged, please contact Bloom Mfg., Inc., 1443 220th Street, Independence, Iowa 50644.

This sample manual is based upon general industry considerations and does not take into account product or manufacturer specific exposures or needs. This sample manual may not be adopted by a product manufacturer as its manual, but may be used by the manufacturer in the process of developing its own manual, based upon its specific products and operations, after consulting with its advisor.

**LIMITED NINETY (90) DAY WARRANTY FOR HYDRAULIC CABLE & CAPSTAN WINCHES**

Effective date March 21, 2007

Bloom Mfg. Inc., Independence, Iowa 50644, provides the following LIMITED NINETY (90) DAY WARRANTY on its product to the purchaser of this product and to any person to whom such product is transferred during the duration of this warranty. The warrantor's obligation shall be limited to repairing or replacing at the factory in Independence, Iowa, any part or parts which shall within the NINETY (90) DAY period hereinafter specified be returned to it with transportation prepaid and which upon examination by Bloom Mfg. Inc. shows to have been defective. This warranty shall not apply if:

- (a) the product has been altered, repaired or modified outside the warrantor's factory in any way that would adversely affect its operation.
- (b) the product has been subject to careless or negligent misuse, damage or use of improper oil while in the possession of the purchaser or any person to whom the product was transferred by the purchaser or was installed or operated other than in accordance with the manufacturer's operating instructions.
- (c) the product was used with accessories not recommended by Bloom Mfg. Inc. or for loads in excess of those listed as rated for the product.
- (d) in the case of hydraulic motors, Bloom Mfg. Inc. will not accept responsibility and warranty will be subject to manufacturer's warranty.

The Warranty Period for the Contract Products delivered under this warranty is ninety (90) days of unrestricted use by the Government of the Prime Contract Items in which the Contract Products are installed. The Warranty Period shall be extended for any period in which the supplies furnished are unavailable for unrestricted use due to failure or defect.

THE IMPLIED WARRANTIES OF MERCHANTABILITY AND FITNESS FOR PARTICULAR PURPOSE ARE LIMITED TO THE DURATION OF THIS WARRANTY - NINETY (90) DAYS - AFTER SAID (90) DAYS, BLOOM MFG. INC. EXPRESSLY DISCLAIMS ANY WARRANTY OR MERCHANTABILITY OR FITNESS FOR ANY PARTICULAR PURPOSE.

Purchase or other acceptance of the product by the claimant shall be on the condition and agreement that BLOOM MFG. INC. SHALL NOT BE LIABLE FOR INCIDENTAL OR CONSEQUENTIAL OR CONTINGENT DAMAGE, SECONDARY CHARGES OR LOSS OR EXPENSE RESULTING FROM ANY ALLEGED DEFECT, FAILURE OF ARTICLE TO OPERATE PROPERLY, OR FOR THE NEGLIGENCE OF OTHERS OR DAMAGES OF ANY KIND.

Bloom Mfg. Inc. is not responsible for the cost, of removal of product, damages due to removal or any other expenses incurred in shipping the product to or from Bloom Mfg. Inc. or the installation of the repaired or replacement product. The consumer must bear these expenses.

To make a claim under this warranty, write directly to Bloom Mfg. Inc., Independence, Iowa 50644, identifying the product and giving its location and follow the company's return instructions which will be provided by the company. Bloom Mfg. Inc. will make its best efforts to repair or replace the product, if found to be defective within the terms of this warranty, within SIXTY (60) DAYS after return of the product to the company.

This warranty is exclusive and in lieu of all other warranties whether written, oral or implied (including any warranty of merchantability or fitness for a particular purpose.



CAUTION

Make sure that there is no load on the winch cable and that all of the hydraulic hoses have been disconnected before servicing unit.

A winch, like other types of machinery, needs to have regular maintenance if it is to perform properly, give lasting service, and provide safe winching.

(a) Clean and Inspect:

Thoroughly clean all of the parts in a good grade of cleaning solvent; one that is not flammable, not toxic and will not cause skin rashes. If necessary, use rubber gloves. Inspect all parts for wear, nicks, scratches and damage that would render them unusable. If a part is questionable, it is better to replace it rather than take a chance on premature failure when the winch is placed back in service. Always replace O-rings and seals, and it is a good idea to use new roll pins as well. Sometimes it is permissible to reuse bearings and bushings...it depends on how much use they have had. The rollers (balls) should not exhibit any surface irregularities. If the rollers (balls) show any sign of spalling, corrosion, discoloration, material displacement or abnormal wear, the bearings should be replaced.

Likewise, the cage should be inspected for unusual wear or deformation, particularly the cage bars. If there is any damage that will impair the cage's ability to separate, retain, and guide the rollers properly, the bearing should be replaced. The thrust washer contact areas should be free from any surface irregularity that might cause excessive abrasion or friction. If the winch was disassembled only to replace damaged seals after a short period of service, it is not necessary to replace the bearings. Experience and common sense, along with a good inspections, will determine if they can be used again. Always coat O-rings, bearings, bushings and the rubber parts of seals with oil during assembly. Use a light coat of thread sealing compound on pipe fittings and plugs.

(b) Oil Change Information:

The winch vent/fill and drain plugs are located in cover of the gear box and at the gear support. Oil should be changed after first 50 hours of operation with subsequent changes every 1000 hours or yearly, whichever comes first.

(c) Oil Level:

To check the oil level, remove the level plug. The oil should be level with the bottom of this opening. If more oil is needed, use the recommended gear oil listed below.

(d) Recommended Gear Oil:

Use BLOOM ULLTRA-LUBE NO. 601 trans-worm gear oil; available from Bloom in pints or quarts. For emergency situations when BLOOM ULLTRA-LUBE No. 601 is not immediately available, use Phillips 66 Company SAE grade 80W90 superior multi-purpose gear oil (Phillips 80W90 SMP) meeting API classification GL-5 or equivalent brand. Continuous use of oil other than BLOOM ULLTRA-LUBE No. 601 or Phillips 80W90 SMP oil may shorten the life of the gears. DO NOT mix BLOOM ULLTRA-LUBE No. 601 or Phillips 80W90 SMP with more than 50% of any other kind of oil.

**OIL
CAPACITY
CHART**

Winch Series	Base Mounted Position
3000KC, 3200KC, 4000KC & 4200KC	4 Quarts (3.8 Liters)



CAUTION

- Winches, like any other kind of machinery, require a "break in" to perform well and to maximize their life.
- Use extreme care when first spooling cable onto the winch. Do not run the winch at high speeds when performing this operation.
- Make sure that the cable is unrolled in a line (to prevent kinks) and slowly inhaul the winch to install the cable.
- Do not exceed one half rated load or one half rated line speed for the first thirty minutes of operation. This will ensure that the gears have an opportunity to wear in properly.



CAUTION

- You must make sure that your winch is securely mounted in order for it to function properly and to ensure safe operation.
- The mount must be flat to ensure proper alignment between the gearbox side, the drum, and the end housing.
- With a hydraulically driven winch, make sure the hydraulic system is clean and that all components function properly, especially the relief valve.

HARDWARE REQUIREMENTS

	Winch Series
	3000KC, 3200KC, 4000KC & 4200KC
Base Mount (steel) Thickness	1.50"
Capscrews (Hexhead) Size Thread Grade (plated)	1" 8 UNC 8
Torque / Tightening (foot pounds)	682

NOTES:

- Tightening torque above is based on use of clean, dry threads.
- Reduced torque by 10% when oil is used as a lubricant.
- Reduced torque by 20% if new plated capscrews are used.



CAUTION

- To familiarize yourself with the winch, run it for a few minutes to understand the controls and the “feel” of the winch.
- Pay particular attention to the controls and how they operate. Make sure you understand which way the winch will rotate when the control lever is moved.
- Always make sure that all people are clear of the load and of the cable area before beginning a winching operation.
- Ensure that proper protective wear is worn while operating winch.
- A broken cable can fly in any direction.
- Do not attempt to defeat the relief valve.

Winch Pulling application:**Clutch Drive:**

- (1) Attach winch cable to load.
- (2) Engage the drum clutch dog (make sure clutch is fully engaged).
- (3) Make sure no one is in the immediate area of the load or of the cable
- (4) Begin winching the load slowly, watching carefully to ensure that the load is moving normally.
- (5) When the load is positioned where you want it, stop the winch.

DRUM CAPACITY

Cable Diameter	Drum Designation					
	S18C	L18C	XL18C	S2012C	L2012C	XL2012C
3/4"	170	300	430	150	260	375
7/8"	120	215	305	95	165	235

Consult your local cable supplier for recommendations on the best type of cable and hardware to use in your specific application.

(a) Cable Considerations:

As the number of layers of cable on a winch increases, the rated pulling capacity of the winch goes down. If you are operating at near the top of the drum flanges, the effective rating of the winch is about half of what it is on the first layer. You should, therefore, only keep as much cable on the winch as you need for your job.

(b) The Importance of a Proper Fleet Angle:

Maintaining the proper fleet angle is important to the success of your winching operation, the life of your winch and the life of the cable you are using. The fleet angle can best be described by the prior diagram: The fleet angle should be kept as small as possible to ensure proper spooling and to maximize cable and winch life. To promote even cable spooling, keep the fleet angle below one and a half degrees. Never pull directly against the flange of the winch cable drum as this may cause the cable or the winch to break. Adherence to these instructions will ensure better spooling.

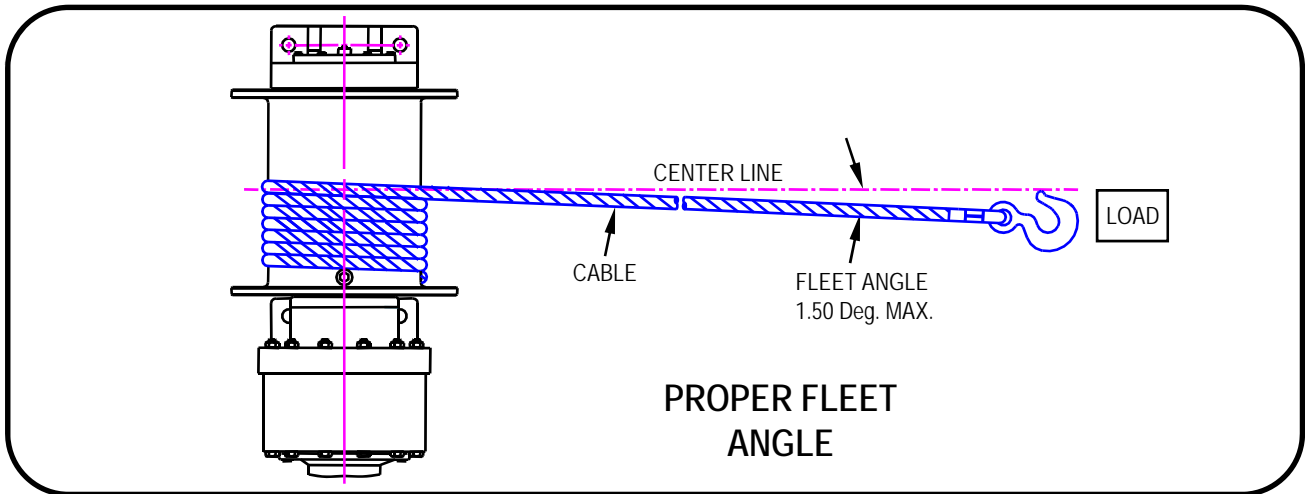

(c) Wire Rope Anchor & Wrapping:

Prepare the end of the wire rope as recommended by the wire rope manufacturer. Pass the free end of the wire rope through the small opening of the cable drum anchor pocket. Lock the cable into the drum by tightening the cable anchor set screw.

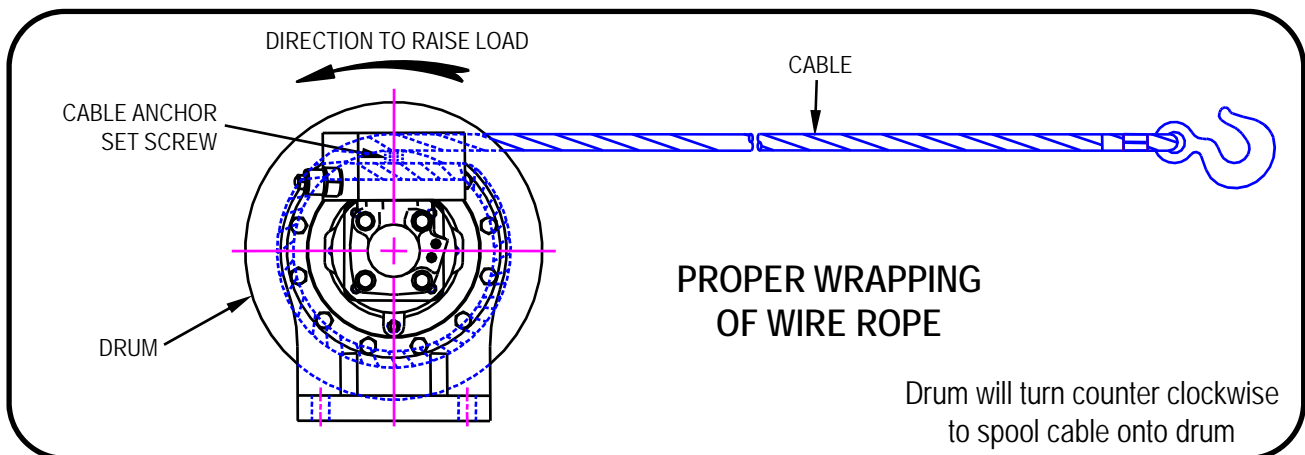

(d) Automatic Hydraulic Fail-Safe Brake (Spring applied hydraulic release)

Spring applied hydraulic release brake automatically holds load when hydraulic pressure is released. Double counter balance valve adds additional load holding capability by locking hydraulic oil in motor.