



Refer to parts breakdown drawing

- 1) Drain oil from gear case.
- 2) Loosen set screw in eccentric collar, then turn collar counter-clockwise with punch to release it from bearing and shaft. ( Ref. 18 )
- 3) Remove clutch housing assembly ( Ref. 17 ) from drum shaft ( Ref. 24 ).
- 4) Remove retaining ring ( Ref. 23 ) and drum ( Ref. 16 ) from shaft.
- 5) Remove keys ( Ref. 25 ) and spacer ( Ref. 15 ) from shaft.
- 6) Remove cover ( Ref. 13 ) from gear case ( Ref. 11 ).
- 7) Loosen nut on hydraulic hose fitting ( Ref. 4 ).
- 8) Remove motor ( Ref. 2 ) from fail-safe brake ( Ref. 3 ).
- 9) Remove fail-safe brake ( Ref. 3 ) from planetary gear box ( Ref. 8 ).
- 10) Carefully remove planetary gear box ( Ref. 8 ) from gear case ( Ref. 11 ).
- 11) Remove retaining ring ( Ref. 12 ) from drive shaft adapter ( Ref. 9 ).
- 12) Remove drive shaft ( Ref. 24 ) and drive shaft adapter ( Ref. 9 ) assembly from gear case ( Ref. 11 ).
- 13) Carefully remove retaining ring ( Ref. 23 ) from drive shaft ( Ref. 24 ) and press drive shaft adapter ( Ref. 9 ) from drive shaft.
- 14) Remove keys ( Ref. 25 ) from drive shaft ( Ref. 24 ).
- 15) Remove ball bearings ( Ref. 10 ) from gear case ( Ref. 11 ).

## Assembly Instructions

## 2000WC Series Planetary Winch

- 1) Clean gear case and all parts thoroughly, inspect all parts and replace if worn or scored.
- 2) Install ball bearings ( Ref. 10 ) into gear case ( Ref. 11 ).
- 3) Carefully press drive shaft adapter ( Ref. 9 ), keys ( Ref. 25 ) onto drive shaft ( Ref. 24 ) and install retaining ring ( Ref. 23 ) onto drive shaft ( Ref. 24 ), then install drive shaft adapter & drive shaft assembly into gear case ( Ref. 11 ) and install retaining ring ( Ref. 12 ).
- 4) Use silicon ( form a gasket ) onto gear case ( planetary gear box side ) ( Ref. 11 ). Align timing mark on planetary gearbox with top-rib of the gear case or at two o'clock ( as shown on parts breakdown ). Then carefully install planetary gear box ( Ref. 8 ) onto gear case ( Ref. 11 ) with (12) 3/8"-24NF x 1-3/4" Hex Head Cap Screws ( Ref. 22 ) ( being sure tighten the screws evenly)
- 5) If removed, install oil seal ( Ref. 14 ) onto cover ( Ref. 14 ).
- 6) Use silicon ( form a gasket ) onto gear case ( Ref. 11 ) ( gear case cover side ). Then install cover ( Ref. 13 ) onto gear case ( Ref. 11 ) with (6) 3/8"-16UNC x 1" Socket Head Cap Screws ( Ref. 20 ). ( being sure tighten the screws evenly)
- 7) Install spacer ( Ref. 15 ) and keys ( Ref. 25 ) onto drive shaft( Ref. 24 ).
- 8) Grease drive shaft ( Ref. 24 ) with multi-purpose lithium grease or equivalent. Place drum ( Ref. 16 ) on drive shaft ( Ref. 24 ) and Install retaining ring ( Ref. 23 ).
- 9) Press end bearing ( Ref. 18 ) into end housing ( Ref. 17 ).
- 10) Refer to "Replacement of Clutch Handle and Yoke" page.  
Slide clutch housing assembly ( Ref. 19 ) toward drum ( Ref. 16 ) until there is about 1/16" clearance between housing ( Ref. 19 ) and drum ( Ref. 16 ) . Place collar ( Ref. 18 ) on bearing being sure it is properly seated on bearing eccentric. Turn collar clockwise with punch until bearing and shaft are held tight, then tighten set screw. The dog is designed to engage fully into the drum when the spring-loaded clutch handle pin is in the hole closest to the drum. Check that the drum turns freely when the clutch handle pin is in the hole farthest from the drum.
- 11) Use silicon ( form a gasket ) onto planetary gear box ( Ref. 8 ) then install fail-safe brake ( Ref. 3 ) onto planetary gear box with (2) 1/2-13NC x 1-1/2" HT Cap Screws & Lock Washers ( Ref. 49 ).
- 12) Install motor ( Ref.2 ) onto fail-safe brake ( Ref. 3 ) with M12 x 1.75 x 30 mm HHCS ( Ref.1 ).
- 13) If removed, align both ends of hydraulic tube ( Ref. 4 ) to the ports ( Ref. 5 & 26 ). Push hydraulic tube ( Ref. 91 ) into installed fitting body ( Ref. 5 & 26 ) on motor ( Ref. 2 ) and fail-safe brake ( Ref. 3 ) until it stops. Fasten nuts and tapered split rings to fittings. Turn nuts hand tight, then with wrench tighten one turn or until rear of tapered split ring is flush with the nut. **Do Not Overtighten.**
- 14) Fill gear box with (3) pints Bloom ULLTRA-LUBE NO. 601 TRANS-WORM GEAR OIL.

**Parts Breakdown**

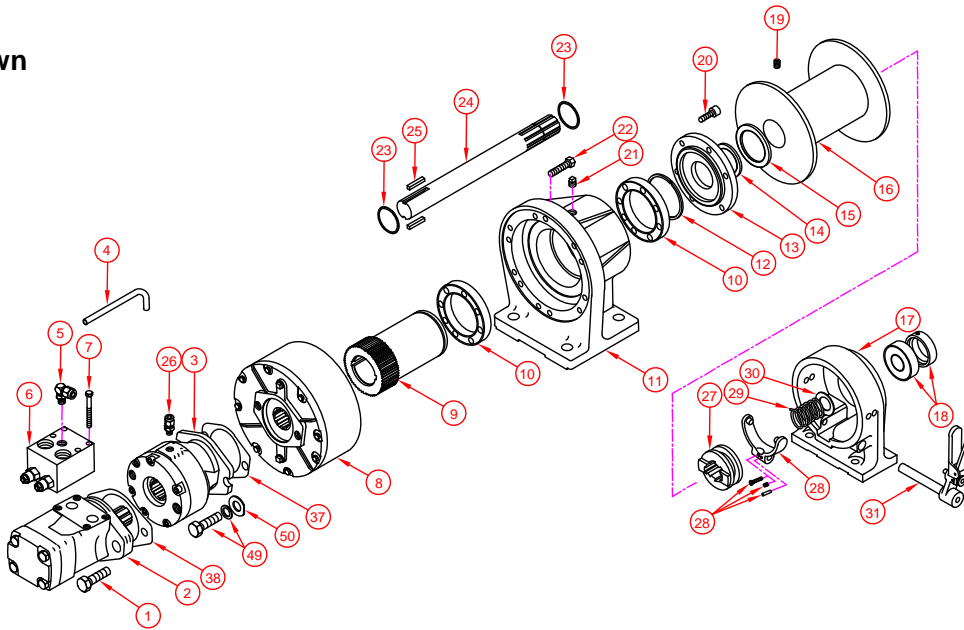

**Hydraulic line assembly  
( Ref. 2, 3, 4, 5, 6 & 26 )**

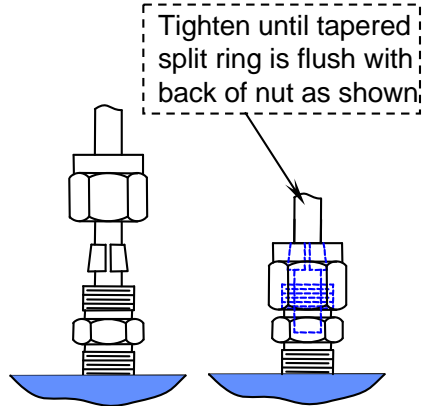
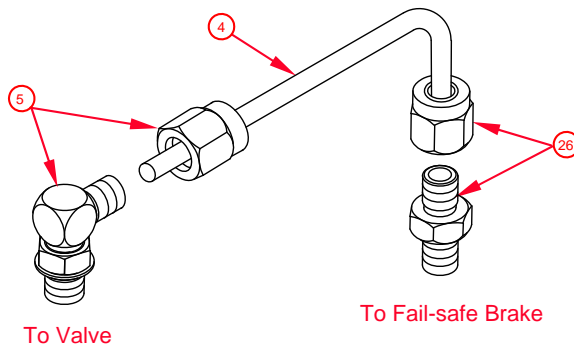

**Shown parts breakdown of planetary gearbox ( Ref. 8 )**

