

Disassembly Instructions 7000 Series Planetary Winches



Refer to parts breakdown drawing

- 1) Drain oil from gear box.
- 2) Loosen hex head cap screws (Ref. 25) on end support cover (Ref. 24), then remove cover from end support (Ref. 23).
- 3) Remove retaining ring (Ref. 13) from drum shaft (Ref. 19).
- 4) Remove end support (Ref. 23) and spacer (Ref. 18) from drum shaft (Ref. 19). If replacement of oil seal (Ref. 15) and ball bearing (Ref. 12) are required, press oil seal and ball bearing out of end support.
- 5) Remove drum (Ref. 21) and keys (Ref. 20) from drum shaft (Ref. 19).
- 6) Remove spacer (Ref. 18) from drum shaft (Ref. 19).
- 7) Loosen nut on hydraulic hose fitting (Ref. 2).
- 8) Loosen Socket head cap screws (Ref. 5), then carefully remove hydraulic motor (Ref. 4) and hydraulic brake (Ref. 7) from planetary gear box (Ref. 8).
- 9) Carefully remove planetary gear box (Ref. 8) from gear support (Ref. 14) by loosening hex nuts (Ref. 9).
- 10) Remove retaining ring (Ref. 13) from drum shaft (Ref. 19).
- 11) Remove drum shaft (Ref. 19) from gear support (Ref. 14).
- 12) Remove cover (Ref. 16) from gear support (Ref. 14) by loosening socket head cap screws (Ref. 17). If replacement of oil seal (Ref. 15) is required, press oil seal out of cover (Ref. 16).
- 13) Remove ball bearings (Ref. 12) from gear support (Ref. 14).

Assembly Instructions 7000 Series Planetary Winches

Refer to parts breakdown drawing

- 1) Clean gear box and all parts thoroughly, inspect all parts and replace if worn or scored.
- 2) Install ball bearings (Ref. 12) into gear support (Ref. 14).
- 3) If removed, lubricate lips of oil seal (Ref. 15) and install onto cover (Ref. 16).
- 4) Use silicon sealant (Silastic RTV732 sealer and General Electric Silimate RTV No. 1473 or RTV No. 1503 are recommended) onto gear support (Ref. 14) (gear support cover side).
Then install cover (Ref. 16) onto gear support (Ref. 14) with (10) 7/16"-14UNC x 1.25" lg. socket head cap screws (Ref. 20). (being sure tighten the screws evenly)
- 5) Carefully install drum shaft (Ref. 19) onto gear support (Ref. 14) and install retaining ring (Ref. 13) onto drum shaft (Ref. 24).
- 6) If removed, install pins (Ref. 11) into gear box (Ref. 8).
- 7) Apply silicone sealant (as recommended above) to face of gear support (gear box side) (Ref. 14). With pins installed, align gear box (Ref. 8) with pin holes on a gear support (Ref. 14). Carefully slide gear box onto gear support and install bolts, hex nuts and lock washers (Ref. 9 & 10).
- 8) Install spacer (Ref. 18) onto drum shaft (Ref. 19).
- 9) Install keys (Ref. 20) into drum shaft (Ref. 19). Grease drum shaft (Ref. 19) with multi-purpose lithium grease or equivalent and install drum (Ref. 21).
- 10) Install spacer (Ref. 18) onto drum shaft (Ref. 19).
- 11) If oil seal (Ref. 15) and ball bearing (Ref. 12) in end support (Ref. 23) have been removed, press in new oil seal and ball bearing.
Note: being sure to lubricate lips of oil seal (Ref. 14) before installing.
- 12) Carefully slide end support (Ref. 23) onto drum shaft (Ref. 19) and install retaining ring (Ref. 13).
- 13) Apply silicone sealant (as recommended above) onto end support cover (Ref. 23).
Then install cover (Ref. 24) onto end support (Ref. 23) with (8) 5/16"-18UNC x 1.25" lg. hex head cap screws (Ref. 25).

Bloom Manufacturing Inc.

- 14) Apply Gasket Eliminator Flange Sealant onto planetary gear box (Ref. 8) and install hydraulic brake (Ref. 7) with gasket (Ref. 6) onto planetary gear box (Ref. 8).
Apply Gasket Eliminator Flange Sealant onto hydraulic brake (Ref. 7) then install hydraulic motor (Ref. 4) and gasket (Ref. 6) with (4) 1/2"-13UNC x 7" lg. grade 8 socket head cap screws and lock washers (Ref. 5).
- 15) If removed, install counterbalance valve (Ref. 1) onto hydraulic motor (Ref. 4) with (8) 3/8"-16UNC x 4-1/2" lg. grade 8 hex head cap screws (Ref. 29).
- 16) If removed, align both ends of hydraulic tube (Ref. 3) to the ports (Ref. 2). Push hydraulic tube (Ref. 2) into installed fitting body (Ref. 2) on counterbalance valve (Ref. 1) and hydraulic brake (Ref. 7) until it stops. Fasten nuts and tapered split rings to fittings. Turn nuts hand tight, then with wrench tighten one turn or until rear of tapered split ring is flush with the nut. Do Not Overtighten.
- 17) Fill gear box to check plug (Ref. 26) with XX quarts (XX liters) Bloom ULLTRA-LUBE NO. 601 TRANS-WORM GEAR OIL.
- 18) If removed, install grease zerk (Ref. 28) onto end support cover (Ref. 24). Attach grease gun to zerk (Ref. 28), fill end support with multi-purpose lithium grease.

Bloom Manufacturing Inc.

Parts Breakdown

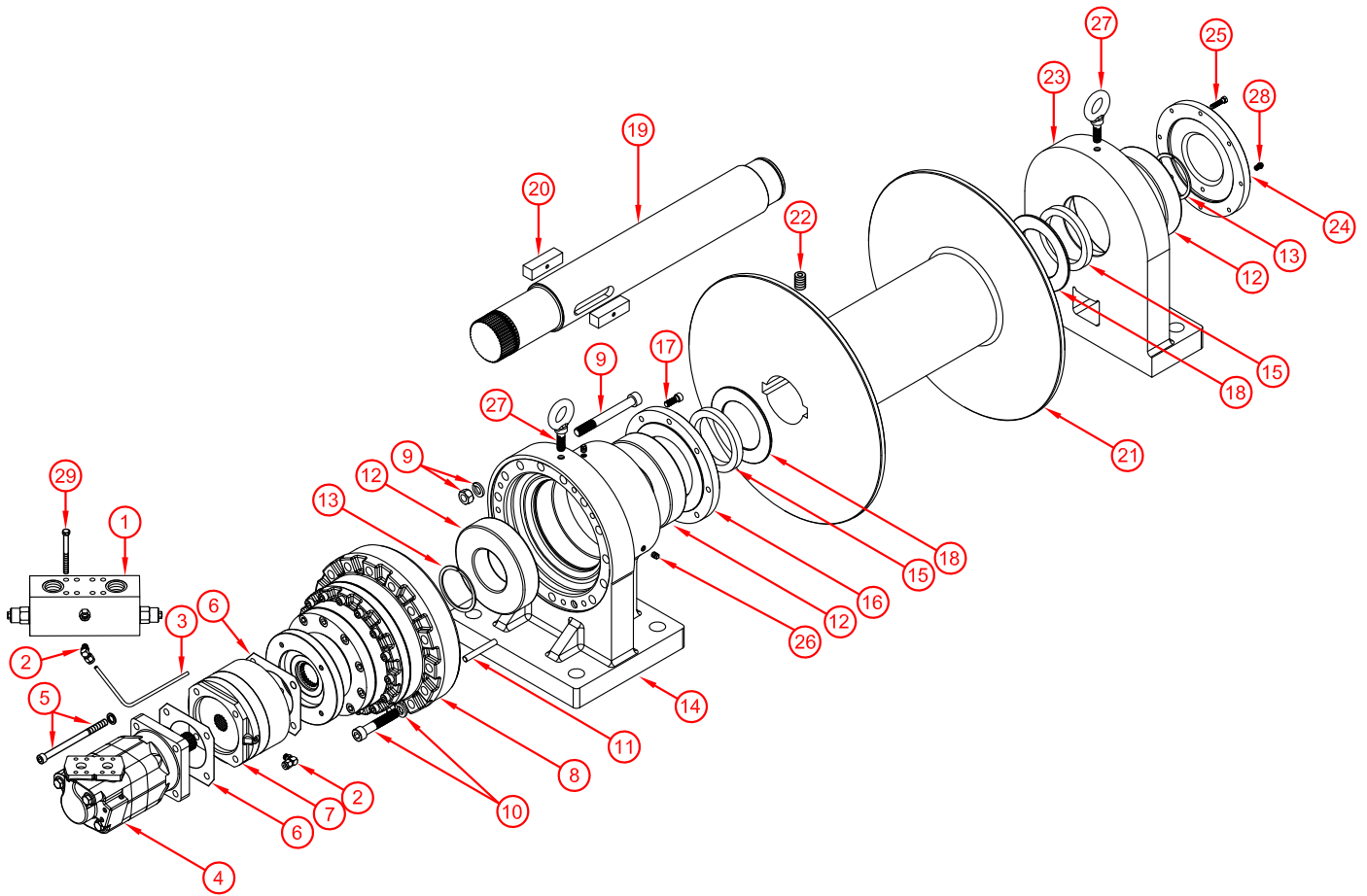

Hydraulic Line Assembly (Ref. 2 & 3)

