

HYDRAULIC MOTOR MOUNT KIT

CAT. NO.	TUBE SIZE	PRICE
620	6"	
820	8"	
1020	10"	

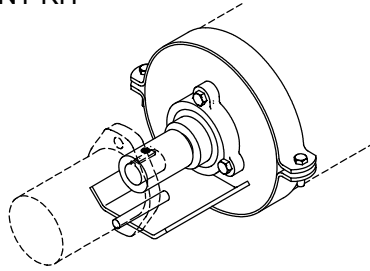

Converts existing auger to hydraulic drive. Hydraulic motor sold separately.

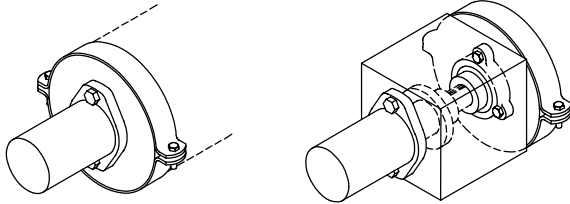

Direct coupled and chain coupled mountings available. Contact factory for pricing.

END BEARING KIT

CAT. NO.	TUBE SIZE	PRICE
422	4"	
522	5"	
622	6"	
822	8"	
1022	10"	

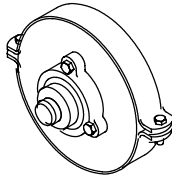

Clamps to end of tube. Includes flange bearing and end shaft.

MOTOR MOUNT KIT

CAT. NO.	TUBE SIZE	PRICE
424	4"	
524	5"	
624	6"	
824	8"	
1024	10"	

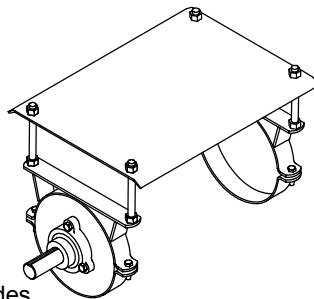

Heavy-duty 10 ga. x 12" x 18" motor plate. 1/2" threaded rods provide easy belt adjustment. Includes flange bearing and drive shaft. Belt guard sold separately.

MOTOR MOUNT

CAT. NO.	TUBE SIZE	PRICE
625	6"	
825	8"	
1025	10"	

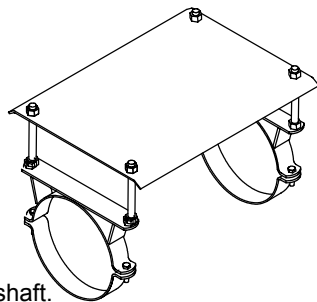

Same as motor mount kit above less end plate, bearing and drive shaft.

TAILCAGE AND END SHAFT

CAT. NO.	TUBE SIZE	PRICE
626	6"	
826	8"	
1026	10"	

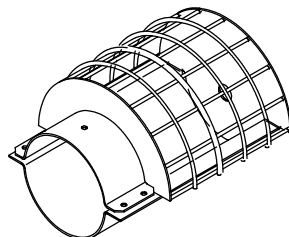

Includes bronze bushing and end shaft. Cut tube 12" short or use tailcage screw shown at top right column.

TAILCAGE SCREW

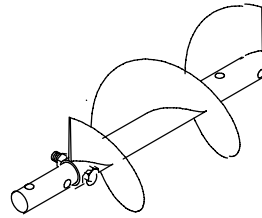

Use with tailcage shown at bottom left column. Includes connector shaft.

CAT. NO.	TUBE SIZE	PRICE
627	6"	
827	8"	
1027	10"	

HANGER BEARING (Includes wood insert)

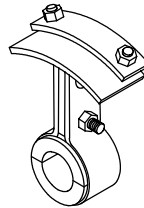

CAT. NO.	TUBE SIZE	BEARING I.D.	PRICE
632	6"	1"	
832	8"	1-1/4"	
1032	10"	1-1/2"	

WOOD INSERT ONLY



CAT. NO.	TUBE SIZE	BEARING I.D.	PRICE
616	6"	1"	
816	8"	1-1/4"	
1016	10"	1-1/2"	

CONNECTOR SHAFT KIT * (for auger w/o hanger bearing)

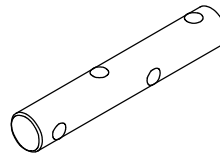

CAT. NO.	SHAFT SIZE	AUGER SIZE	PRICE
436	3/4"	4"	
536	3/4"	5"	
636	1"	6"	
836	1-1/4"	8"	
1036	1-1/2"	10"	

CONNECTOR SHAFT KIT * (for auger with hanger bearing)

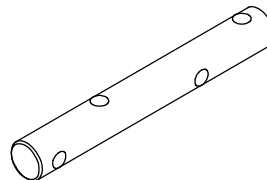

CAT. NO.	SHAFT SIZE	AUGER SIZE	PRICE
637	1"	6"	
837	1-1/4"	8"	
1037	1-1/2"	10"	

DRIVE SHAFT KIT *

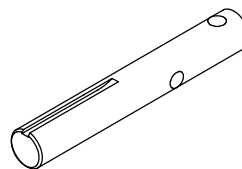

CAT. NO.	SHAFT SIZE	AUGER SIZE	PRICE
438	1"	4"	
538	1"	5"	
638	1"	6"	
838	1-1/4"	8"	
1038	1-1/2"	10"	

END SHAFT KIT *

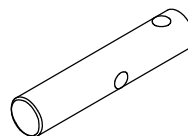

CAT. NO.	SHAFT SIZE	AUGER SIZE	PRICE
439	1"	4"	
539	1"	5"	
639	1"	6"	
839	1-1/4"	8"	
1039	1-1/2"	10"	

* All shafts made from high-strength cold rolled steel. All include grade 5 cap screws and locknuts.

CLAMPING SLEEVE, 1-PC. (for augers w/o hanger bearing)

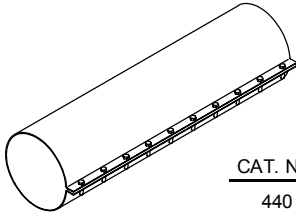

CAT. NO.	SIZE	LENGTH	PRICE
440	4"	15"	
540	5"	16"	
640	6"	30"	
840	8"	30"	
1040	10"	30"	

CLAMPING SLEEVE, 2-PC. (for augers w/ hanger bearing)

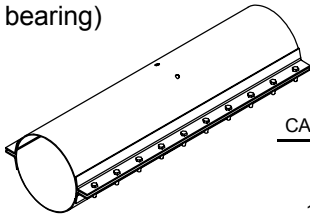

CAT. NO.	TUBE		PRICE
	SIZE	LENGTH	
641	6"	30"	
841	8"	30"	
1041	10"	30"	

Both made from 14 ga. steel for strong, straight connection.

RIGHT ANGLE CROSSOVER

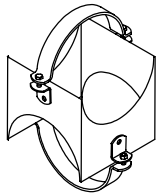

CAT. NO.	SIZE	PRICE
444	4"-4"	
544	5"-5"	
644	6"-6"	
844	8"-8"	
1044	10"-10"	

Connects two horizontal or one vertical and one horizontal auger at 90 deg. Each auger requires its own power.

SEALED INLET

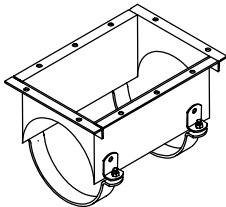

CAT. NO.	TUBE	OPENING	PRICE
	SIZE	SIZE	
646	6"	6" x 12-3/4"	
846	8"	8" x 12-3/4"	
1046	10"	8" x 12-3/4"	

Intake can be attached to outlets of hoppers, dryers, etc. for a weather-tight material inlet.

PRESSURE HOPPER W/ Slide Gate and Intake Guard.

CAT. NO.	AUGER SIZE	TOTAL HEIGHT	DIS-	PRICE
			CHARGE TUBE	
647	6"	29"	6"	
847	8"	28-3/8"	8"	

18" x 18" opening. Use to feed auger from end or drop straight through using slide gate. Includes end bearing, end shaft and intake guard.

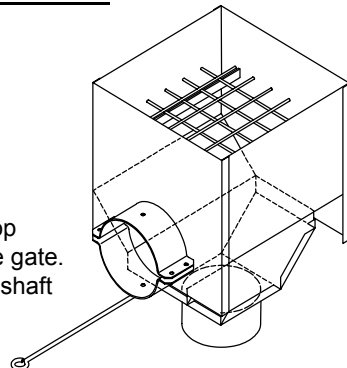

PRESSURE HOPPER with Intake Guard

CAT. NO.	TUBE	TOTAL	PRICE
	SIZE	HEIGHT	
648	6"	18"	
848	8"	18"	

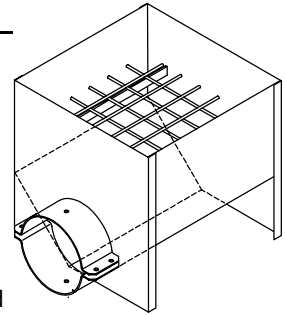

18" x 18" opening. Use to feed auger from end or pressure feed right angle corner for vertical augers. Includes end bearing, end shaft and intake guard.

PRESSURE HOPPER SCREW

CAT. NO.	TUBE		PRICE
	SIZE	PRICE	
649	6"		
849	8"		

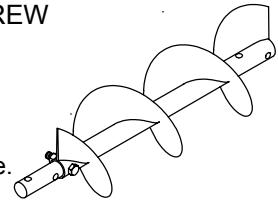

Use W/ pressure hopper above. Included connector shaft.

INLET HOPPER W/ Intake Guard

CAT. NO.	TUBE	A	PRICE
	SIZE		
450	4"	10"	
550	5"	9-1/2"	
650	6"	9"	
850	8"	8"	
1050	10"	7"	

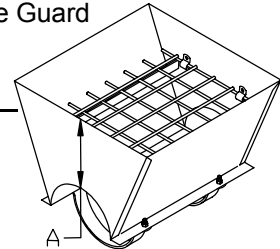

18" x 18" opening. Hopper can be mounted anywhere on auger. Clamps are included.

HOPPER COVER

CAT. NO.	HOPPER	PRICE
	SIZE	
202	ALL	

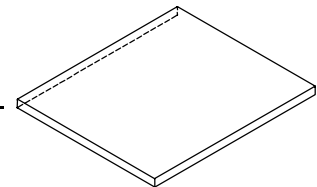

Fits all 18" x 18" hoppers. Hinges are included. Constructed of 14 ga. Steel.

ROUND OUTLETS

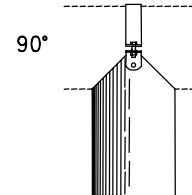
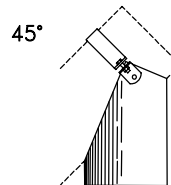

CAT. NO.	TUBE SIZE	PRICE	PRICE W/
			FLANGE
452	4"		
552	5"		
652	6"		
852	8"		
1052	10"		

CAT. NO.	TUBE SIZE	PRICE	PRICE W/
			FLANGE
453	4"		
553	5"		
653	6"		
853	8"		
1053	10"		

Add "F" to catalog number for welded-on round flange.

LONG DROP WITH SLIDE GATE

CAT. NO.	TUBE SIZE	PRICE	PRICE W/ FLANGE
654	6"		
854	8"		
1054	10"		

Measurements are the same as A and B Below.

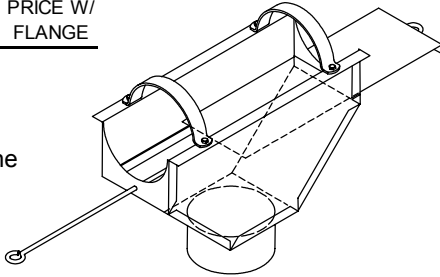

Drop material directly into bin from auger or attach spouting or flex tube. When ordering flange attached, add "F" to catalog.

LONG DROP W/O SLIDE GATE

CAT. NO.	TUBE SIZE	PRICE	PRICE W/ FLANGE
655	6"		
855	8"		
1055	10"		

TUBE SIZE	A	B
6"	16-1/2"	10-7/8"
8"	23-7/8"	13-3/4"
10"	23-7/8"	12-13/16"

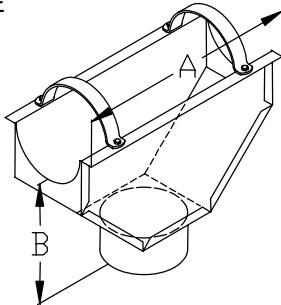

45 deg. "Y"

CAT. NO.	TUBE SIZE	PRICE
656	6"	
856	8"	
1056	10"	

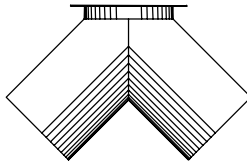

Diverts material into two spouts. Attach to drop or outlet with flange.

FLEX SPOUT

CAT. NO.	TUBE SIZE	LENGTH TUBE	PRICE
458	4"	2'	
558	5"	2'	
658	6"	3'	
858	8"	3'	

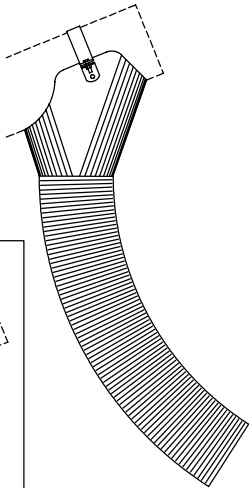

Directs material to hard to reach places.

FLEX SPOUT ADAPTER

CAT. NO.	TUBE SIZE	PRICE
459	4"	
559	5"	
659	6"	
859	8"	

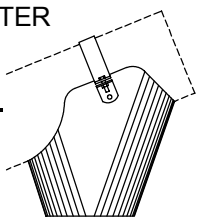

Same as above less flex tubing.

FLEX TUBING

CAT. NO.	TUBE SIZE	PRICE/FT.
460	4"	
560	5"	
660	6"	
860	8"	
1060	10"	

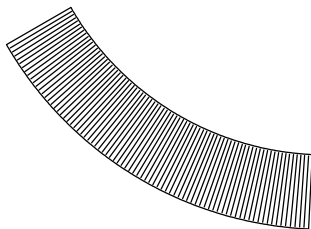

Flexible galvanized steel tubing.

SEAL OUTLET

CAT. NO.	TUBE SIZE	OUTLET TUBE	PRICE
662	6"	6" x 6"	
862	8"	8" x 8"	
1062	10"	10" x 10"	

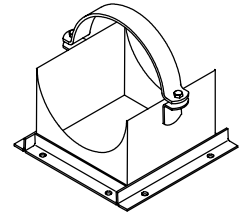

Attaches to auger outlet. Can be connected directly to a building or hopper.

ADJUSTABLE ELBOWS – 2 pcs.

CAT. NO.	TUBE SIZE	PRICE
664	6"	
864	8"	

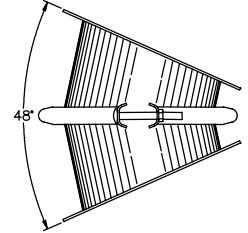

Adjusts 0 deg. – 48 deg. Includes two elbows and one flange clamp ring.

ADJUSTABLE ELBOWS – 3 pcs.

CAT. NO.	TUBE SIZE	PRICE
665	6"	
865	8"	

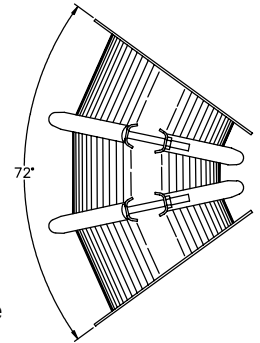

Adjusts 0 deg. – 72 deg. Includes three elbows and two flange clamp rings.

FLANGE CLAMP RING

CAT. NO.	TUBE SIZE	PRICE
466	4"	
566	5"	
666	6"	
866	8"	
1066	10"	

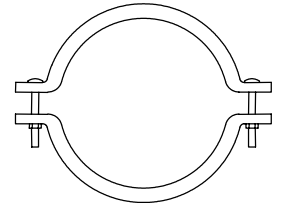

(2 pcs.) with bolts and nuts.

ROUND FLANGE

CAT. NO.	TUBE SIZE	PRICE
467	4"	
567	5"	
667	6"	
867	8"	
1067	10"	

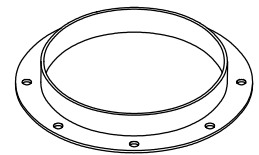

Heavy rolled ring.

45 deg. DEADHEAD

NO.	SIZE	PRICE
668	6"	
868	8"	
1068	10"	

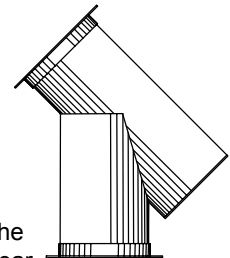

Use in place of 45 deg. Elbow to slow the force of falling grain and reduce tube wear. Outlasts a 45 deg. Elbow many times.

SQUARE TO ROUND ADAPTER

CAT. NO.	SIZE		PRICE
	RD.	SQ.	
671	6"	6"	
771	6"	8"	
871	8"	8"	

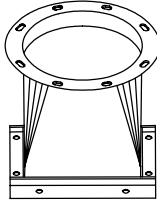

Allows attachment of standard flanged tubing to square outlet and valves.

END TRUSS BRACKET

CAT. NO.	TUBE		PRICE
	SIZE		
476	4"		
576	5"		
676	6"		
876	8"		
1076	10"		

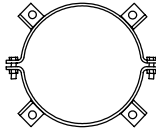

CENTER TRUSS BRACKET

CAT. NO.	TUBE SIZE	ARM DIA.	LENGTH OF ARM	PRICE
577	5"	1"	18"	
677	6"	1"	18"	
877	8"	1"	18"	
1077	10"	1-1/2"	30"	

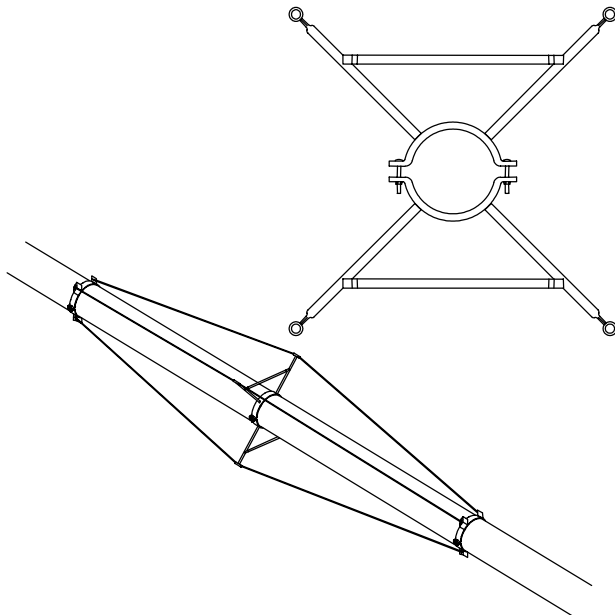

We recommend use of truss supports when spanning over 20 feet of unsupported auger. End truss brackets be located as near to the auger tube supports as possible. Maximum recommended span between truss brackets is 15 feet. 1/4" steel cable attached to eye bolts is recommended for the trusses.

FLAT TOP ADAPTER

CAT. NO.	SIZE		PRICE
	RD.	SQ.	
673	6"	6"	
674	6"	8"	
874	8"	8"	

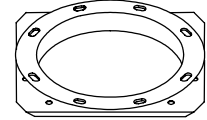

Allows attachment of standard flanged tubing to square inlet and valves.

TUBE CLAMP

CAT. NO.	SIZE	WIDTH	PRICE
478	4"	1-1/2"	
479	4"	4"	
470	4"	8"	
578	5"	1-1/2"	
579	5"	4"	
570	5"	8"	
678	6"	1-1/2"	
679	6"	4"	
670	6"	8"	
878	8"	1-1/2"	
879	8"	4"	
870	8"	8"	
1078	10"	1-1/2"	
1079	10"	4"	
1070	10"	8"	

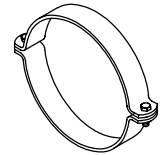

Two pieces clamp with bolts and nuts.

MOUNTING BRACKET

CAT. NO.	TUBE		PRICE
	SIZE		
472	4"		
572	5"		
672	6"		
872	8"		
1072	10"		

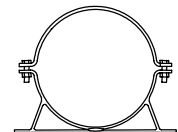

Attaches auger directly to supporting structure or can be used telescoping supports.

TELESCOPEING SUPPORT

CAT. NO.	SIZE	PRICE/PAIR
272	12" to 18"	
273	18" to 36"	
274	36" to 72"	
275	SPECIAL	

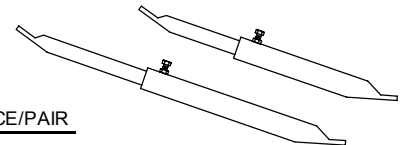

Adjustable supports attach to mounting brackets or tube clamps to support auger.

CABLE, WIRE ROPE

CAT. NO.	SIZE	PRICE/FT
276	1/4"	
278	5/16"	

Aircraft steel cable.

CABLE CLAMP

CAT. NO.	SIZE	PRICE
277	1/4"	
279	5/16"	



TWO WAY PAN VALVE

CAT. NO.	SIZE	PRICE
880	8"	

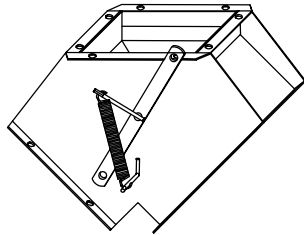

Strong welded steel construction. Can be easily controlled by rope from the ground. Requires 1 flat top and 2 square to round adapters.

45 DEGREE DIVERTER PAN VALVE

CAT. NO.	SIZE	PRICE
881	8"	

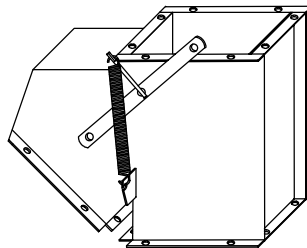

Strong welded steel construction. Can be easily controlled by rope from the ground. Requires 1 flat top and 3 square to round adapters.

THREE WAY PAN VALVE

CAT. NO.	SIZE	PRICE
882	8"	

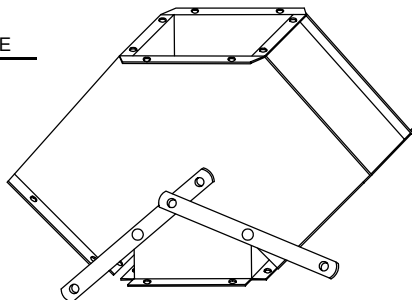

Strong welded steel construction. Can be easily controlled by rope from the ground. Requires 1 flat top and 2 square to round adapters.

EYE BOLT (WITH 2 NUTS)

CAT. NO.	SIZE	PRICE
283	1/2" x 6"	



"L" CLAMP CLIP FOR U-TROUGH

CAT. NO.	SIZE	RD.	SQ.	PRICE
284	ALL			

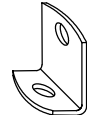

Replace clamp half on outlets and drops bolted to side of u-trough.

BELT GUARD

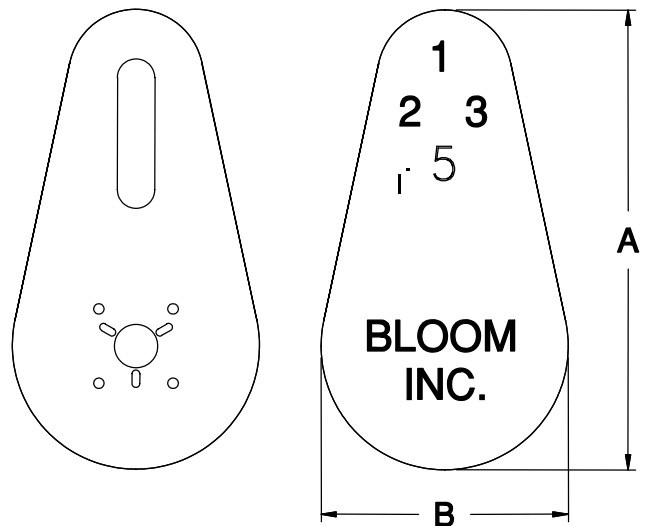

CAT. NO.	SIZE	"A"	"B"	GUARD NO.	PRICE
585	12" STEEL	25	13	#1	
685	12" STEEL	31	14	#2	
785	18" STEEL	30	20	#3	
985	16" STEEL	27-3/8	17-3/4	#5	

Made of steel for extra strength and durability. Belt guard fastens between end bearing plate and end bearing. Belt guard must be in place at all times. Disconnect electrical power and lock out electrical control before removing belt guard for maintenance. Reinstall belt guard before reconnecting power to motor.