

Disassembly Instructions LS30K, LS32K, LS40K & LS42K Series Planetary Winch



Refer to parts breakdown drawing

- 1) Drain oil from gear box.
- 2) Loosen Socket head cap screws (Ref. 28) on the cover (Ref. 27), then remove cover from end support (Ref. 26).
- 3) Remove retaining ring (Ref. 12) from drum shaft (Ref. 24).
- 4) Remove end support (Ref. 26) and spacer (Ref. 15) from drum shaft (Ref. 24). If replacement of oil seal (Ref. 14) and ball bearing (Ref. 10) are required, press oil seal and ball bearing out of end support.
- 5) Remove drum (Ref. 16) and keys (Ref. 25) from drum shaft (Ref. 24).
- 6) Remove spacer (Ref. 15) from drum shaft (Ref. 24).
- 7) Loosen nut on hydraulic hose fitting (Ref. 90).
- 8) Loosen Socket head cap screws (Ref. 1), carefully remove hydraulic motor (Ref. 4) and hydraulic brake (Ref. 5) from planetary gear box (Ref. 8).
- 9) Carefully remove planetary gear box (Ref. 8) from gear support (Ref. 11) by loosening hex nuts (Ref. 7).
- 10) Remove retaining ring (Ref. 12) from drum shaft (Ref. 24).
- 11) Remove drum shaft (Ref. 24) from gear support (Ref. 11).
- 12) Remove cover (Ref. 13) from gear support (Ref. 11) by loosening socket head cap screws (Ref. 20). If replacement of oil seal (Ref. 14) is required, press oil seal out of cover (Ref. 13).
- 13) Remove ball bearings (Ref. 10) from gear support (Ref. 11).

Assembly Instructions LS30K, LS32K, LS40K & LS42K Series Planetary Winch

Refer to parts breakdown drawing

- 1) Clean gear box and all parts thoroughly, inspect all parts and replace if worn or scored.
- 2) Install ball bearings (Ref. 10) into gear support (Ref. 11).
- 3) If removed, lubricate lips of oil seal (Ref. 14) and install onto cover (Ref. 13).
- 4) Use silicon sealant (Silastic RTV732 sealer and General Electric Silimate RTV No. 1473 or RTV No. 1503 are recommended) onto gear support (Ref. 11) (gear support cover side).
Then install cover (Ref. 13) onto gear support (Ref. 11) with (8) 7/16"-14UNC x 1" lg. 18-8 stainless steel socket head cap screws (Ref. 20). (being sure tighten the screws evenly)
- 5) Install drum shaft (Ref. 24) onto gear support (Ref. 11) and install retaining ring (Ref. 12) onto drum shaft (Ref. 24).
- 6) If removed, first apply silicone sealant (as recommended above) to face of gear support (Ref. 11) that mates with ring gear (Ref. 8I), assembly ring gear (Ref. 8I) to gear support (Ref. 11) being careful to align all the bolt holes.
- 7) Install the secondary carrier assembly (Ref 8H) into ring gear (Ref. 8I) and onto splined end drum shaft (Ref. 24).
- 8) Install the primary carrier assembly (Ref. 8G) into ring gear (Ref. 8I). It will be necessary to rotate carrier (Ref. 8G) to align secondary carrier (Ref. 8H) and ring gear (Ref. 8I).
- 9) Install primary sun gear (Ref. 8F) into primary carrier assembly (Ref. 8G). Sun gear (Ref. 8F) should turn freely by hand when assembled.
- 10) Apply silicone sealant (as recommended above) to cover face of ring gear (Ref. 8I). Secure thrust washer (Ref. 8E) with tangs engaged in gear box cover (Ref. 8D).
Note: Washer (Ref. 8E) can be secured to gear box cover (Ref. 8D) with a small amount of grease or silicone sealant.
Assemble gear box cover (Ref. 8D) to ring gear (Ref. 8I) with (12) 1/2"-13UNC x 9" lg. grade 8 hex head cap screws, lock washers and hex nuts (Ref. 7). (being sure tighten the screws evenly)
- 11) Install spacer (Ref. 15) onto drum shaft (Ref. 24).
- 12) Install keys (Ref. 25) into drum shaft (Ref. 24). Grease drum shaft (Ref. 24) with multi-purpose lithium grease or equivalent and install drum (Ref. 16).
- 13) Install spacer (Ref. 15) onto drum shaft (Ref. 24).
- 14) If oil seal (Ref. 14) and ball bearing (Ref. 10) in end support have been removed, press in new oil seal and ball bearing.
Note: being sure to lubricate lips of oil seal (Ref. 14) before installing.
- 15) Carefully slide end support (Ref. 26) onto drum shaft (Ref. 24) and install retaining ring (Ref. 12).
- 16) Apply silicone sealant (as recommended above) onto end support cover (Ref. 27)
Then install cover (Ref. 27) onto end support (Ref. 26) with (6) 5/16"-18UNC x 1" lg. 18-8 stainless steel socket head cap screws (Ref. 28).

Bloom Manufacturing Inc.

- 17) Use silicon sealant (as recommended on page 1) onto planetary gear box cover (Ref. 8) and install hydraulic brake (Ref. 5) onto planetary gear box (Ref. 8).
Apply silicon sealant (as recommended on page 1) onto hydraulic brake (Ref. 5) then install hydraulic motor (Ref. 4) with (4) 1/2"-13UNC x 7" lg. grade 8 socket head cap screws and lock washers (Ref. 1).
- 18) If removed, install counterbalance valve (Ref. 2) onto hydraulic motor (Ref. 4) with (8) 3/8"-16UNC x 4-1/2" lg. grade 8 hex head cap screws (Ref. 3).
- 19) If removed, align both ends of hydraulic tube (Ref. 91) to the ports (Ref. 90). Push hydraulic tube (Ref. 91) into installed fitting body (Ref. 90) on counterbalance valve (Ref. 2) and hydraulic brake (Ref. 5) until it stops. Fasten nuts and tapered split rings to fittings. Turn nuts hand tight, then with wrench tighten one turn or until rear of tapered split ring is flush with the nut. Do Not Overtighten.
- 20) Fill gear box to check plug with (4) quarts (3.8 liters) Bloom ULLTRA-LUBE NO. 601 TRANS-WORM GEAR OIL.
- 21) Attach grease gun to zerk (Ref. 29), fill end support with multi-purpose lithium grease.

Bloom Manufacturing Inc.

Parts Breakdown

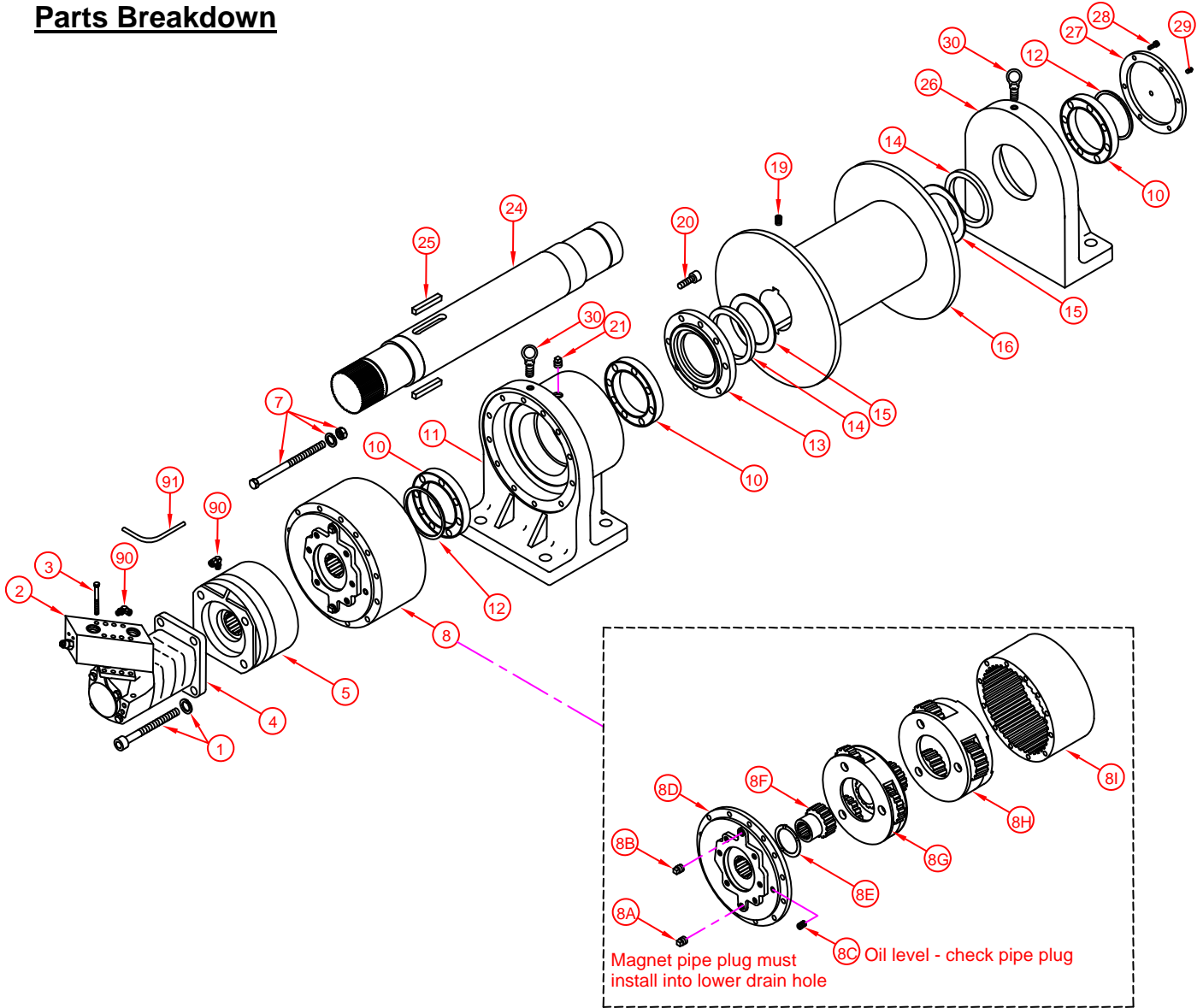

Hydraulic Line Assembly

(Ref. 90 & 91)

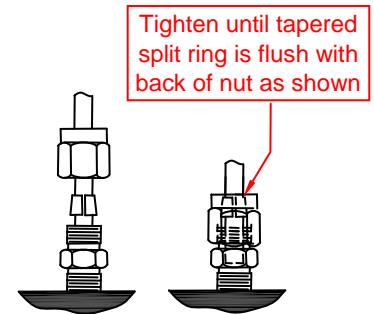
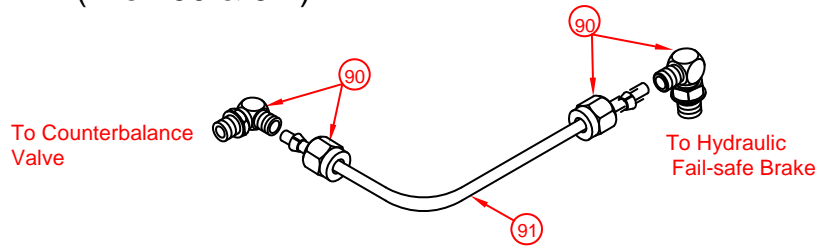

Bloom Manufacturing Inc.