

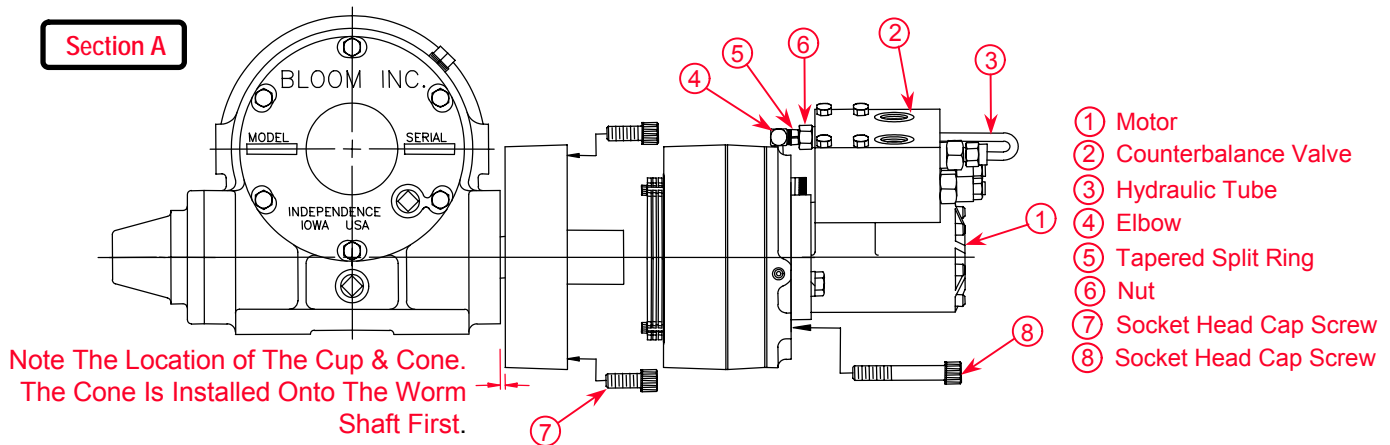

- 1) Drain oil from gear case.
- 2) Loosen set screw in eccentric collar, then turn collar counter-clockwise with punch to release it from bearing and shaft.
- 3) Remove end housing from drum shaft.
- 4) Remove retaining ring and drum from shaft.
- 5) Remove wear block.
- 6) **Hydraulic Released Fail-Safe Brake & Motor Removal (Section A & Section C)**
 - a) Loosen jam nuts and locking nuts to remove brake line.
 - b) Remove (4) 5/16" X 3" (AM motor) hex head cap screws. Remove counterbalance valve.
 - c) Loosen and remove (2) 1/2" X 1-1/4" (AM motor) socket head cap screws. Remove motor from back of brake unit.
 - d) Loosen and remove (2) 1/2" X 3" socket head cap screws from back of brake housing. Split brake unit into 2 parts.
 - e) Loosen and remove (2) 7/16" X 1" socket head cap screws and remove brake housing from gear case.
 - d) Remove end cap, bearing, spacer and worm shaft from gear case.
- 7) Remove worm shaft and bearings from gear case.
- 8) Remove gear case cover.
- 9) Remove bronze gear and drum shaft as a unit being careful not to damage shaft seal.

Note: Bronze gear is press fit on shaft. **DO NOT** remove unless absolutely necessary.



Assembly Instructions

1200K Series Winch

- 1) Clean gear case and all parts thoroughly, inspect oil seal and replace if worn or scored.
- 2) If bronze gear has been removed from shaft, care should be used to press the gear onto the shaft squarely. Press gear and keys onto shaft simultaneously. Locate end of gear hub (the set screw side) 3/4" from the shaft end (Section B).
- 3) If removed Install oil seal and bearings. Install drum shaft assembly into gear case carefully to prevent damage to the shaft seal.
- 4) Bolt cover to gear case without shim gaskets. Tighten the screws lightly and evenly. Measure clearance between cover and gear case with feeler gage (Section B) and remove cover. For proper bearing pre-load, install shim gaskets (red - .002", blue - .005", brown - .010") onto cover as required with a thickness that is .003" to .005" less than the measurement. Re-bolt cover assembly

Section B

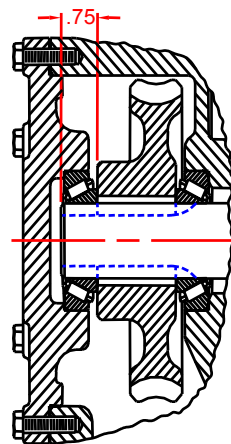

Do Not Use Hammer To Install Bronze Gear Onto Shaft

MEASURE CLEARANCE WITH CAP SCREWS TIGHTENED LIGHTLY

- 5) Install worm shaft in gear case. Install bearing cones such that the large end of each cone seats against each worm shoulder (Section C). Install bearing cups and thrust spacers. Spacer on end cap side is 1.06 wide. Install end cap gasket kit ((2) .010 brown gaskets) and end cap using (4) 7/16" x 1-1/2" socket head cap screws.

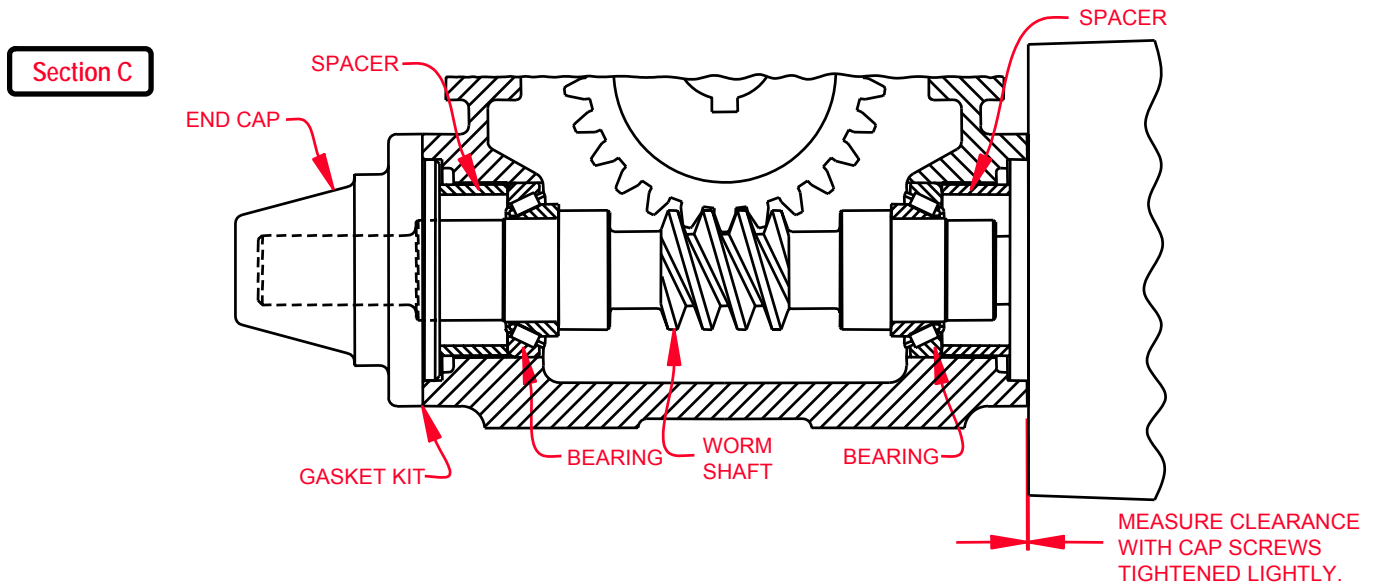

- 6) Hydraulic Released Fail-safe Brake & Motor Assembly (Section A)
- Install round head woodruff key into brake output shaft. Make sure thrust spacer is against bearing. Bolt front brake housing to gear case without shim gaskets with (2) 7/16" X 1" socket head cap screws. Tighten the screws lightly and evenly. Measure clearance with a feeler gage and remove front brake housing (Section B). For proper bearing pre-load, install shim gaskets (red - .002", blue - .005", brown .010") as required with a thickness that is .003" - .005" less than the measurement. Re-bolt front brake housing securely.
 - Bolt back half of brake housing to front half with the (2) 1/2" X 3" socket head cap screws.
 - Install square head woodruff key into motor shaft and bolt motor to back of brake using (1) (W-239) brown motor gasket and (2) 1/2" X 1-1/4" socket head cap screws.
 - Bolt double counterbalance valve to motor manifold bearing end cap using O-Rings provided and (4) 5/16" X 3" (AM motor) hex head cap screws.
 - Install brake line into 7/16" male elbows on counterbalance valve and brake (If installing a new brake line it may be necessary to cut brake line to fit). Tighten jam nuts on male elbows to hold in place. Tighten locking nuts on elbows to hold brake line in place. Turn nut only until tapered split ring starts to come through the back side or the brake line side of the nut.
- 7) Grease drum shaft with multi-purpose lithium grease or equivalent and install wear block and drum. Install retaining ring. Place end housing assembly on drum shaft and slide toward drum until there is about 1/16" clearance between housing and drum. Place collar on bearing being sure it is properly seated on bearing eccentric. Turn clockwise with punch until bearing and shaft are held tight, then tighten set screw.
- 8) Base Mounted: Fill gear case with (2) pints, All Other Mounting Positions: Fill gear case with (3) pints **Bloom ULLTRA-LUBE NO. 601 TRANS-WORM GEAR OIL**; available from Bloom in pints or quarts. For emergency situations when **Bloom ULLTRA-LUBE NO. 601** is not immediately available, use Phillips 66 Company SAE grade 80W90 superior multi-purpose gear oil (Phillips 80W90 SMP) meeting API classification GL-5 or equivalent competing brand. Continuous use of oil other than **Bloom ULLTRA-LUBE NO. 601** or Phillips 80W90 SMP may shorten the life of the gears. **DO NOT** mix **Bloom ULLTRA-LUBE NO. 601** or Phillips 80W90 SMP with more than 50% of any other kind of oil.