



- 1) Drain oil from gear case.
- 2) Loosen set screw in eccentric collar, then turn collar counter-clockwise with punch to release it from bearing and shaft.
- 3) Remove end housing (direct drive) or clutch housing (clutch drive) assembly from drum shaft.
- 4) Remove retaining ring and drum from shaft.
- 5) Remove phenolic friction block & spring (clutch model) or wear block (direct drive) from gear case.
- 6) Remove motor from gear case.
- 7) Remove worm shaft and bearings from gear case.
- 8) Remove gear case cover.
- 9) Remove bronze gear and drum shaft as a unit being careful not to damage shaft seal.

Note: Bronze gear is press fit on shaft. **DO NOT** remove unless absolutely necessary.

Model number prefix (stamped in gear case cover) indicates model series and drum shaft size:

- No prefix designates 1000 series winch with 1-1/4" drum shaft
- Prefix "10" designates 1000 series winch with 1-1/2" drum shaft
- Prefix "27" designates 1000 series winch with 1-1/2" drum shaft and old style 27:1 ratio gears
- Prefix "11" designates 1100 series winch with 1-1/2" drum shaft

Assembly Instructions

1000, 1000C, 1100 & 1100C Series Winches

- 1) Clean gear case and all parts thoroughly, inspect oil seal and replace if worn or scored.
- 2) If bronze gear has been removed from shaft, care should be used to press the gear onto the shaft squarely. Press gear and keys onto shaft simultaneously. Locate end of gear hub (the set screw side) 21/32" from the shaft end on 1-1/4" shaft models and 3/4" on 1-1/2" shaft models (Section A).

Section A

A DIM.	SHAFT DIA.
21/32	1-1/4
3/4	1-1/2

**Do Not
Use Hammer
To Install
Bronze Gear
Onto Shaft**

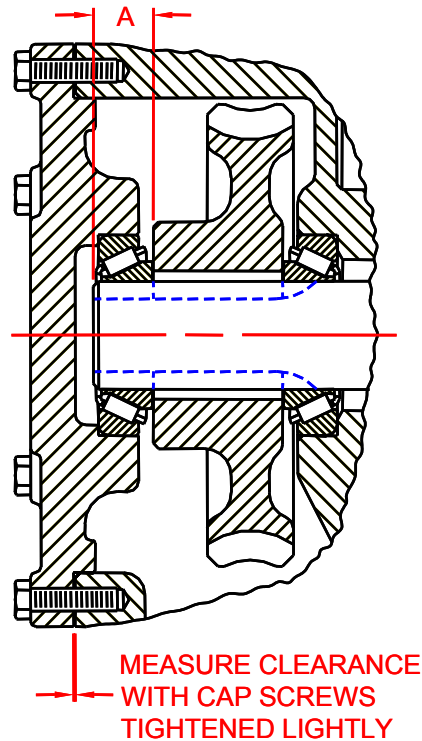

- 3) If removed, Install oil seal in gear case.
- 4) Install gear and shaft assembly (with bearings) into gear case carefully to prevent damage to the shaft seal.
- 5) Bolt cover to gear case without shim gaskets. Tighten the screws lightly and evenly. Measure clearance between cover and gear case with feeler gage and remove cover. For proper bearing pre-load, install shim gaskets (red - .002", blue - .005", brown - .010") onto cover as required with a thickness that is .003" to .005" less than the measurement. Re-bolt cover securely. Check bearing thrust by turning drum shaft. Shaft must turn freely but with just a slight amount of resistance.
- 6) Install bearing cone (.75" diameter inside dimension) into bearing pocket. Install worm shaft. Be sure that the shaft end opposite the motor is seated properly in the bearing cone. Install bearing cone and cup on motor end being sure large end of bearing cone is seated against worm gear shoulder (Section B).

Section B

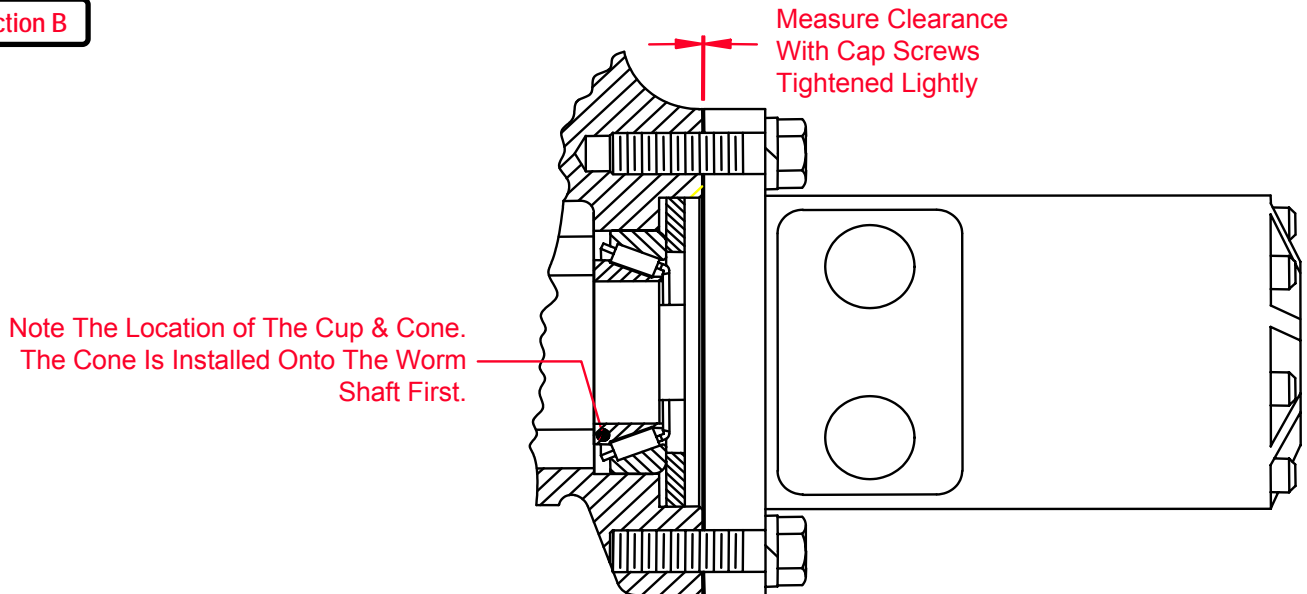

- 7) Place thrust spacer against bearing. Bolt motor to gear case without shim gaskets with cap screws and lock washers. Tighten the screws lightly and evenly. Measure clearance between motor and gear case with a feeler gage (Section B) and remove motor. For proper bearing pre-load, install shim gaskets (red - .002", blue - .005", brown - .010") as required with a thickness that is .003" to .005" less than the measurement. Re-bolt motor securely.
- 8) DIRECT DRIVE: Grease drum shaft with multi-purpose lithium grease or equivalent and install wear block and drum. Install retaining ring. Place end housing assembly on drum shaft and slide toward drum until there is about 1/16" clearance between housing and drum. Place collar on bearing being sure it is properly seated on bearing eccentric. Turn clockwise with punch until bearing and shaft are held tight, then tighten set screw.
CLUTCH DRIVE: Grease drum shaft with multi-purpose lithium grease or equivalent. Install spring and phenolic friction block in gear case. Place drum on shaft and install retaining ring to hold drum against friction block. If yoke is not already securely fastened to clutch handle shaft, refer to "Replacement of Clutch Handle and Yoke" page. Grease clutch dog groove and place on drum shaft with spring and washer. Install clutch housing assembly on drum shaft placing yoke in clutch dog groove. Slide clutch housing toward drum until there is about 1/16" clearance between housing and drum. Place collar on bearing being sure it is properly seated on bearing eccentric. Turn collar clockwise with punch until bearing and shaft are held tight, then tighten set screw. The dog is designed to engage fully into the drum when the spring-loaded clutch handle pin is in the hole closest to the drum. Check that the drum turns freely when the clutch handle pin is in the hole farthest from the drum. Refer to "Replacement of Clutch Handle and Yoke" page.
- 9) Base Mounted: Fill gear case with (1) pint, All Other Mounting Positions: Fill gear case with (2) pints **Bloom ULLTRA-LUBE NO. 601 TRANS-WORM GEAR OIL**; available from Bloom in pints or quarts. The hardened steel worm shaft must run in oil. For emergency situations when Bloom ULLTRA-LUBE NO. 601 is not immediately available, use Phillips 66 Company SAE grade 80W90 superior multi-purpose gear oil (Phillips 80W90 SMP) meeting API classification GL-5 or equivalent competing brand. Continuous use of oil other than Bloom ULLTRA-LUBE NO. 601 or Phillips 80W90 SMP may shorten the life of the gears. DO NOT mix Bloom ULLTRA-LUBE NO. 601 or Phillips 80W90 SMP with more than 50% of any other kind of oil.