

## Series LS32K

### **Hydraulic Planetary Cable Winches**

Lift-Safe® hydraulic winches are specifically designed for lifting applications and optimum load control. Engineered for enhanced safety with redundant braking systems, and available in a variety of configurations. Lift-Safe® winches utilize the **DUET-SAFE® Double Action Braking System** to provide both static and dynamic braking. LS32K Series direct drive winches are used for industrial pulling and hoisting applications, fishing boats, marine craft, drill rigs, cranes, factory material handling and roll off waste handlers.



(Special grooved drum shown)

**UP TO 15,000 LBS.  
CAPACITY**

## **Lift-Safe® Hydraulic Cable Winches – Standard Features**

- |                       |  |
|-----------------------|--|
| <b>BRAKE</b>          | - <b>DUET-SAFE® Double Action Braking System</b> combines a powerful spring applied, hydraulic released brake with a double counter balance brake valve to automatically hold loads when hydraulic pressure is released and control speed during lowering operations. Winch is ideal for high speed lifting and pulling applications or wherever load holding is critical. |
| <b>GEAR CASE</b>      | - Made of high strength steel. Completely sealed for oil enclosed operation and to keep dirt out.  |
| <b>PLANETARY GEAR</b> | - High Efficiency Double Reduction – Rugged - Built to Last.   |
| <b>GEAR RATIO</b>     | - 17:1 standard.   |
| <b>BEARINGS</b>       | - Drum Shaft is supported by two heavy duty oil lubricated bearings in gear case, and one permanently sealed ball bearing in end housing.  |
| <b>DRUM SHAFT</b>     | - 4" diameter heat-treated alloy steel   |
| <b>CABLE DRUM</b>     | - Tough all steel construction resists breakage or warping.  |





## 3200K Series Model Selection from Performance Data

**MODEL EXAMPLE: LS32K-15.0M -L2012-17**

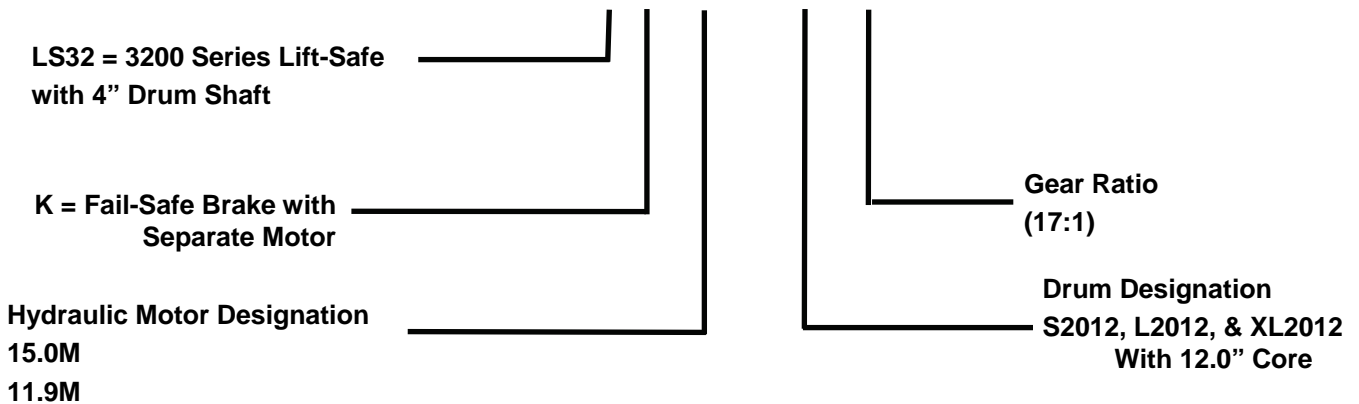

(32K) Indicates a 3200K Series winch with 4" drum shaft, and standard fail-safe brake.

(15.0M) Designates hydraulic motor. Motor size is determined from motor performance charts. All motors come complete with attached double counter balanced valve.

(L2012) Drum designation.

(17) Indicates gear ratio. 17:1 is standard.



*"Quality Since  
1910"*

# Lift-Safe® Planetary Cable Winches

## 3200K Series W/ 12" Core

With Hydraulic Fail-safe Brake

Model Selection from Performance Data



"Quality Since 1910"

17:1 RATIO

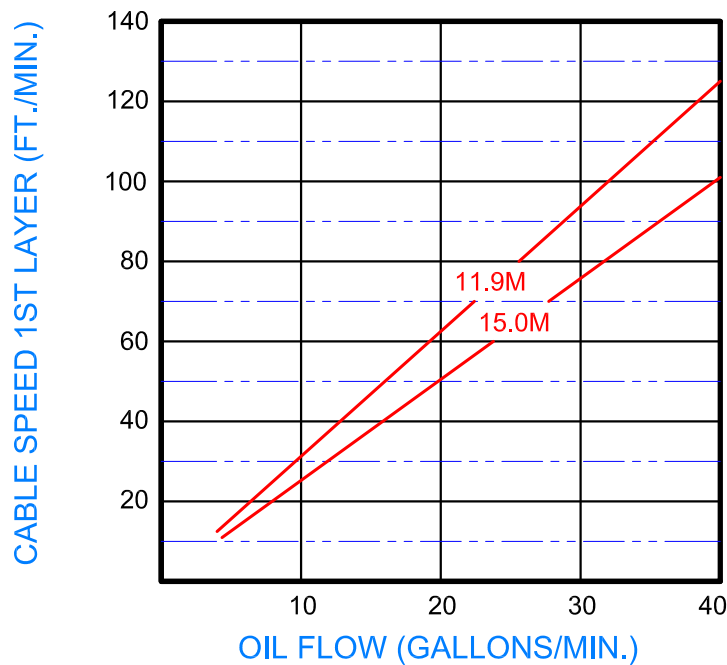
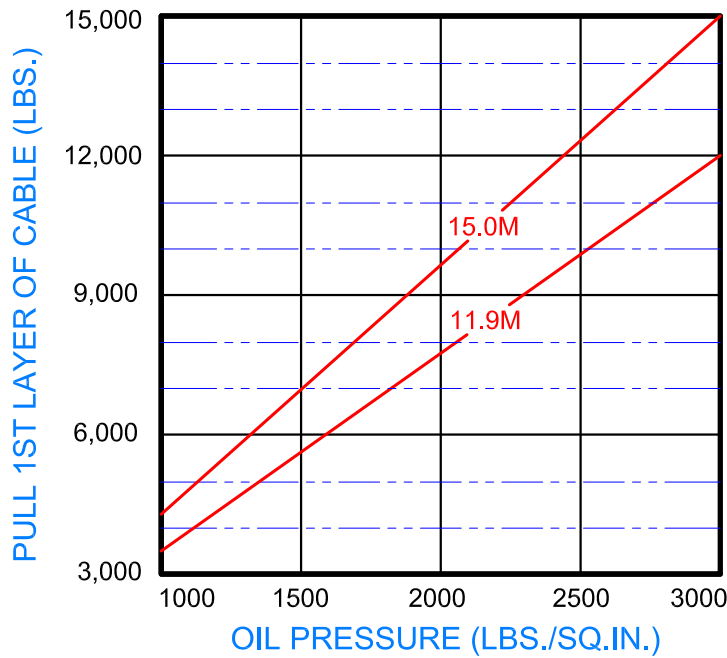



**"Quality Since  
1910"**

# LIFT-SAFE®

## Dimensional Drawings

3200K Series W/ 12" Core  
Base Mount Model - Direct Drive

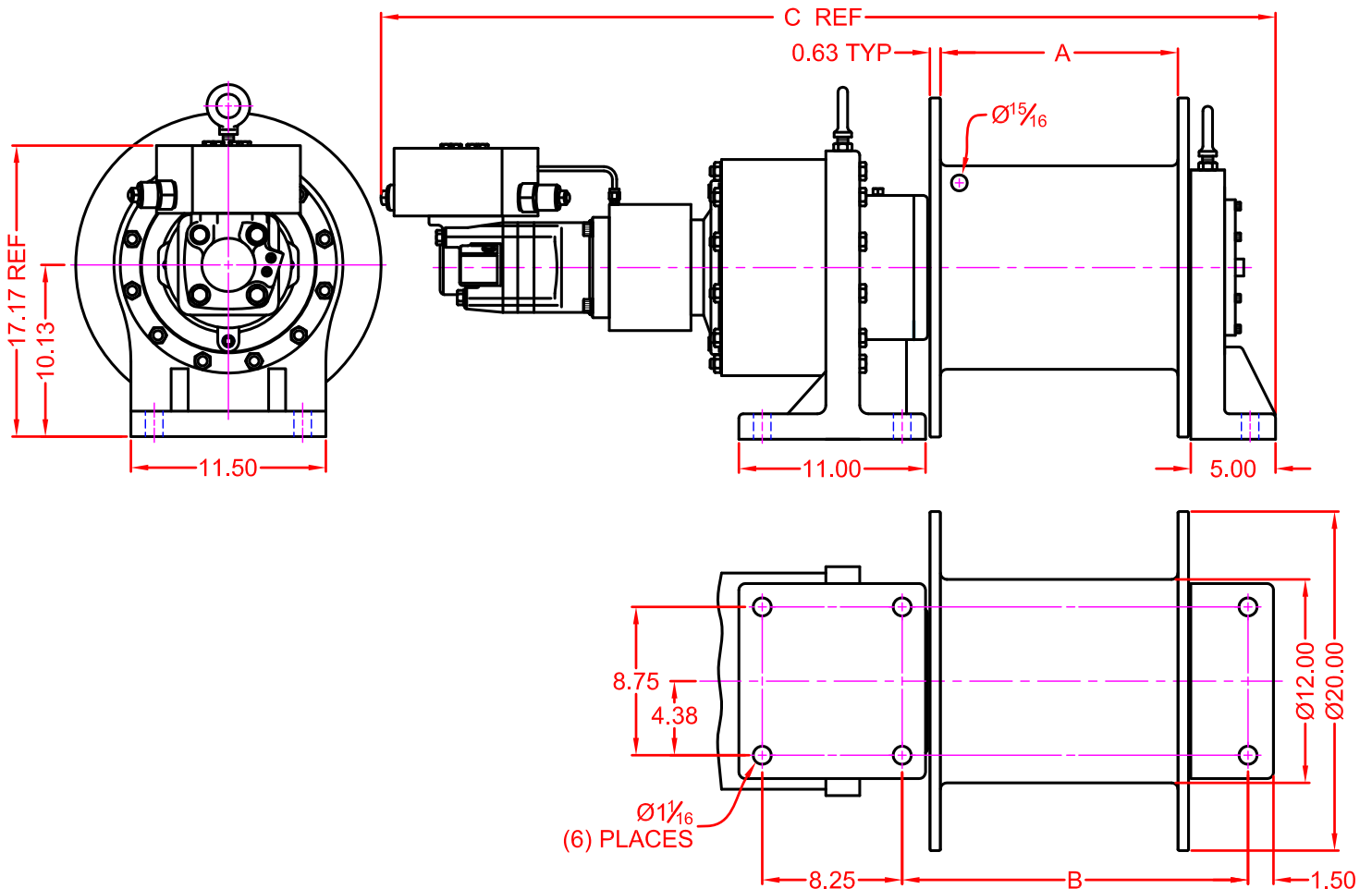

WINCH DIMENSION	DRUM DESIGNATION		
	S2012	L2012	XL2012
A DIMENSION	8	14	20
B DIMENSION	14.39 ±0.06	20.39 ±0.06	26.39 ±0.06
C DIMENSION	46.75	52.75	58.75

CABLE SIZE ( INCH )	CABLE CAPACITY ( FT. )		
	S2012 DRUM	L2012 DRUM	XL2012 DRUM
Ø3/4"	150	260	375
Ø7/8"	95	165	235



Correct choice of Directional Control Valves for Lift-Safe® Winches

All **Lift-Safe®** Winches require a **Motor Spool Control Valve**.

That is the valve's work ports are **open** to tank in neutral position.

\*Winches require ridged mounting plate.  
See owner's manual for information about proper mounting plate thickness or call Bloom Sales Engineer at factory

**WARNING!**

Goods are not intended for use in the moving or lifting of persons!

The winches described herein are neither designed nor intended for use or application to equipment used in the lifting or moving of persons and it is understood that all such use shall be at the sole risk of the user.

The cable clamps on winches are not designed to hold rated loads. A minimum of 5 wraps of cable must be left on drum barrel to guarantee holding of rated load.

Applications of winch where life would be endangered by any event are not recommended.



**BLOOM Manufacturing Inc.**  
**Winch Division**

1443 220<sup>th</sup> Street,, Independence, Iowa 50644

FAX 319-827-1140 PHONE 319-827-1139

[www.bloommfg.com](http://www.bloommfg.com)

©Copyright 2010 Bloom Mfg. Inc.