

Series LS21H

"Quality Since
1910"

Hydraulic Planetary Cable Winches

Lift-Safe® hydraulic winches are specifically designed for lifting applications and optimum load control. Engineered for enhanced safety with redundant braking systems, and available in a variety of configurations. Lift-Safe® winches utilize the **DUET-SAFE® Double Action Braking System** to provide both static and dynamic braking. LS21H Series direct drive winches are used for industrial pulling and hoisting applications, fishing boats, marine craft, drill rigs, small cranes, factory material handling and rear load waste handlers.



**UP TO 11,000 LBS.
CAPACITY**

Lift-Safe® Hydraulic Cable Winches – Standard Features

- MOTOR-BRAKE** - **DUET-SAFE® Double Action Braking System** combines a powerful spring applied, hydraulic released motor-brake with a double counter balance valve to automatically hold loads when hydraulic pressure is released and control speed during lowering operations. Winch is ideal for high speed lifting and pulling applications or wherever load holding is critical.
- GEAR CASE** - Made of high strength steel. Completely sealed for oil enclosed operation and to keep dirt out.
- PLANETARY GEAR** - High Efficiency Double Reduction – Rugged - Built to Last.
- GEAR RATIO** - 17:1 standard.
- BEARINGS** - Drum Shaft is supported by two heavy duty oil lubricated bearings in gear case, and one permanently sealed ball bearing in end housing.
- DRUM SHAFT** - 2-1/4" diameter heat-treated alloy steel minimum tensile strength 150,000 psi.
- CABLE DRUM** - Tough all steel construction resists breakage or warping.



BLOOM
Manufacturing Inc.
Winch Division

**Lifting
Pulling
Hoisting**

Toll Free Number: 1-800-394-1139



"Quality Since 1910"

Series 2100H Model Selection from Performance Data

MODEL EXAMPLE: LS21(H)-6.2T -L1410-17

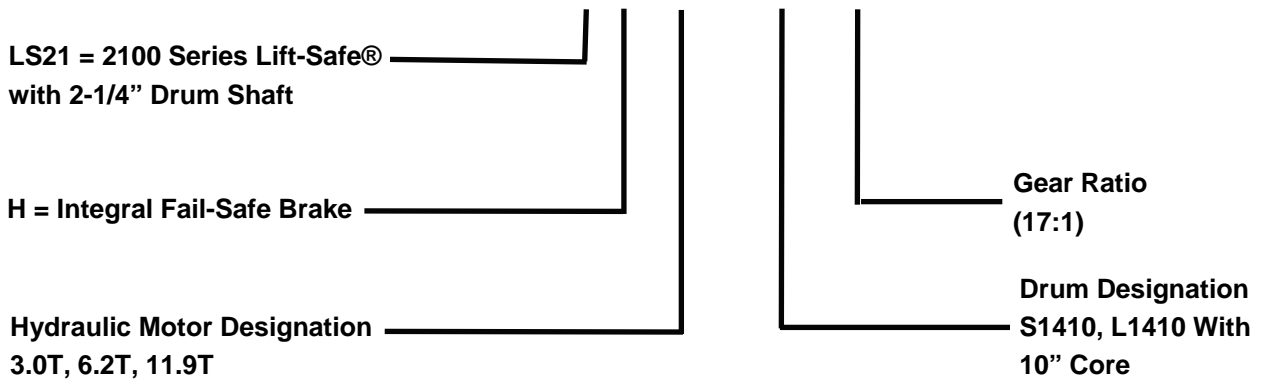

PRES
PRO

(21H) Indicates a 2100H Series winch with 2 1/4" drum shaft. The "H" indicates T series motor with standard fail-safe brake.

(3.2T) Designates hydraulic motor. Motor size is determined from motor performance charts. All motors come with integral spring applied hydraulic release brake.

(L1410) Drum designation.

DRUM CAPACITY

CABLE DIAMETER (IN.)	5/16	3/8	7/16	1/2	9/16	5/8
DRUM "S1410" CAPACITY (FT.)	330	220	140	125	70	65
DRUM "L1410" CAPACITY (FT.)	595	395	250	220	130	115

(17) Indicates gear ratio. 17:1 is standard.

2100H Series Model Selection from Performance Data

17:1 RATIO

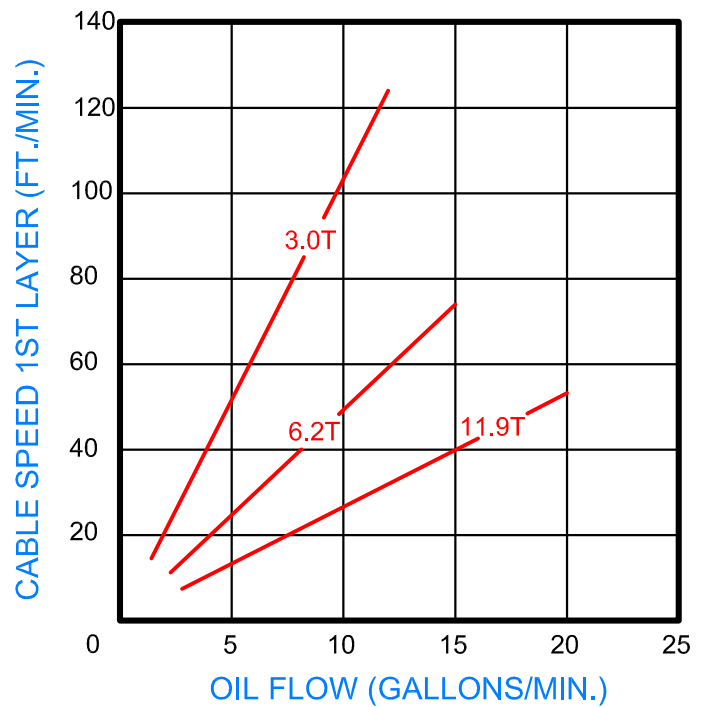
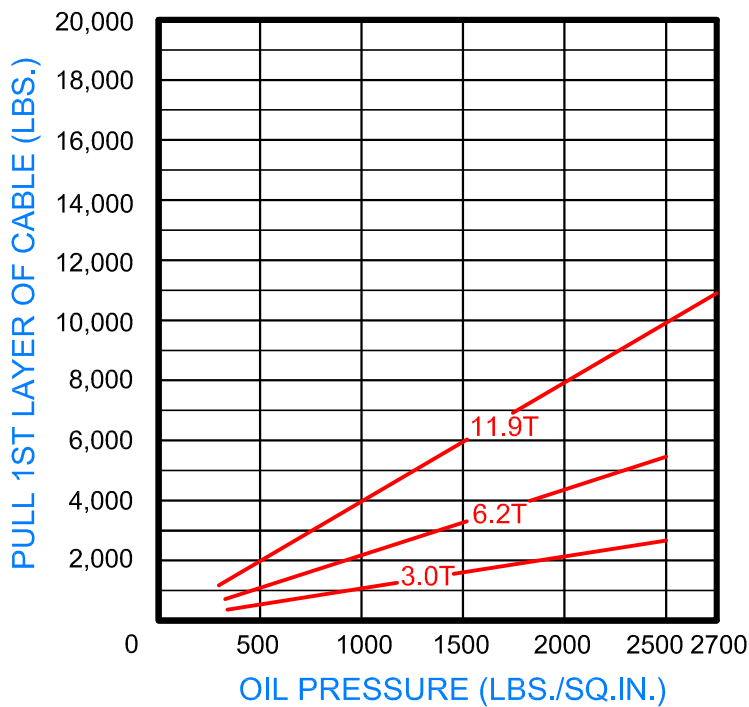



"Quality Since
1910"

LIFT-SAFE®

Dimensional Drawings

2100H Series
Base Mount Model - Direct Drive

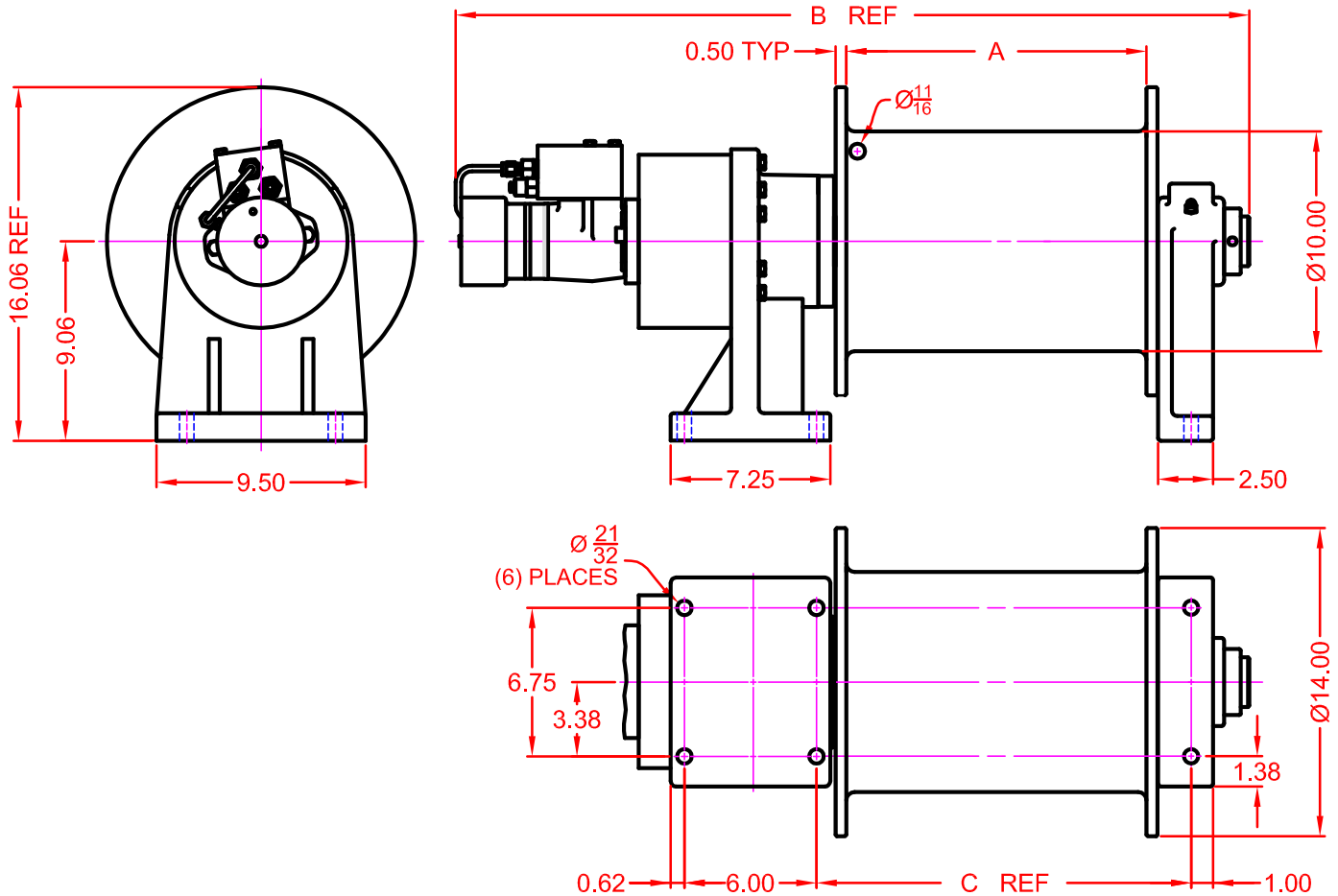

B DIMENSION	MOTOR DESIGNATION		
	3.0T	6.2T	11.9T
S1410 DRUM	29.58	30.05	30.32
L1410DRUM	35.58	36.05	36.32

WINCH DIMENSION	DRUM DESIGNATION	
	S1410 DRUM	L1410 DRUM
A DIMENSION	7.63	13.63
C DIMENSION	11.02	17.02



Correct choice of Directional Control Valves for Lift-Safe® Winches

All **Lift-Safe®** Winches require a **Motor Spool Control Valve**.

That is the valve's work ports are **open** to tank in neutral position.

*Winches require ridged mounting plate.
See owner's manual for information about proper mounting plate thickness or call Bloom Sales Engineer at factory

WARNING!

Goods are not intended for use in the moving or lifting of persons!

The winches described herein are neither designed nor intended for use or application to equipment used in the lifting or moving of persons and it is understood that all such use shall be at the sole risk of the user.

The cable clamps on winches are not designed to hold rated loads. A minimum of 5 wraps of cable must be left on drum barrel to guarantee holding of rated load.

Applications of winch where life would be endangered by any event are not recommended.



BLOOM Manufacturing Inc.
Winch Division

1443 220th Street,, Independence, Iowa 50644

FAX 319-827-1140 PHONE 319-827-1139

www.bloommfg.com

©Copyright 2010 Bloom Mfg. Inc.