

Series LS10K

"Quality Since
1910"

HYDRAULIC CABLE WINCHES

Lift-Safe® hydraulic winches are specifically designed for lifting applications and optimum load control. Engineered for enhanced safety with redundant braking systems, and available in a variety of configurations. Lift-Safe® winches utilize the **DUET-SAFE® Double Action Braking System** to provide both static and dynamic braking. Lift-Safe® winches offer increased operational flexibility, and superior load control in lifting applications. The LS10K Series are direct drive and can be used on small cranes, rear load waste packers, drill rigs, fishing boats, marine craft, construction booms, mining and logging operations.



LIFT-SAFE 10K Series
Base Mount Shown

UP TO 12,000 LBS. CAPACITY

Lift-Safe® Hydraulic Cable Winches – Standard Features

- BRAKE** - **DUET-SAFE® Double Action Braking System** combines a powerful spring applied, hydraulic released brake with a double counter balance brake valve to automatically hold loads when hydraulic pressure is released and control speed during lowering operations. Winch is ideal for high speed lifting and pulling applications or wherever load holding is critical.
- GEAR CASE** - Made of high strength cast iron. Completely sealed for oil enclosed operation and to keep dirt out.
- WORM SHAFT** - One piece alloy steel hardened and ground for extra durability. Compact design allows hydraulic motor to be coupled directly to worm.
- WORM GEAR** - High tensile aluminum-nickel alloy bronze. Optimum lead and pressure angles transmit maximum power to the drum.
- GEAR RATIO** - 20:1 standard, 10:1, 27:1, 40:1 optional ratios provide optimum efficiency in power and speed.
- BEARINGS** - Worm gear and worm shaft run on tapered roller bearings. Outer end housing has sealed ball bearing.
- DRUM SHAFT** - 1-1/2" diameter heat-treated alloy steel minimum tensile strength 150,000 psi.
- CABLE DRUM** - Tough all steel construction resists breakage or warping.



BLOOM

Manufacturing Inc.

Winch Division

Lifting
Pulling
Hoisting

Toll Free Number: 1-800-394-1139

www.bloommfg.com

"Custom Engineered Solutions"

1443 220th Street,, Independence, Iowa 50644 • FAX: 319-827-1140 • PHONE: 319-827-1139

1000K Series Model Selection from Performance Data

MODEL EXAMPLE: **LS10K-4.9M-L8-10-LP**

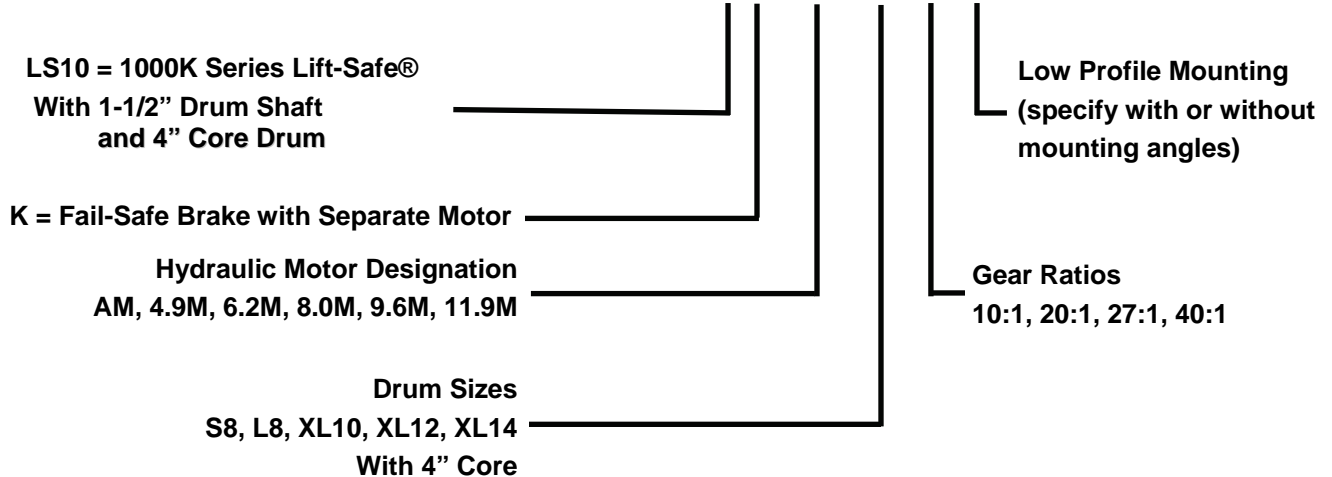

(10K) Indicates winch series. "10K" indicates a 1000K Series winch with 1-1/2" drum shafts and are available up to 12,000 lbs. capacity. The "K" indicates spring applied hydraulic released fail safe brake.

(4.9M) Designates hydraulic motor. Motor size is determined from motor performance charts. All motors come complete with attached double counter balanced valve.

(L8) Select drum size from chart below:

DRUM CAPACITY

CABLE DIAMETER (IN.)	1/4	5/16	3/8	7/16	1/2
DRUM "S8" CAPACITY (FT.)	260	160	105	75	55
DRUM "L8" CAPACITY (FT.)	390	240	160	110	80
DRUM "XL10" CAPACITY (FT.)	840	550	340	250	170
DRUM "XL12" CAPACITY (FT.)	1320	840	580	380	280
DRUM "XL14" CAPACITY (FT.)	1900	1180	760	540	410

(10) Indicates gear ratio. 10:1 is standard. 20:1, 27:1, and 40:1 are also available.

(LP) Design low profile mounting on 1000K Series winches. 1000K Low Profile Series winches with mounting angles are available with S8 and L8 drums. However, it is necessary on all low profile whether the winch is to be supplied "with angles" or "less angles".

Series 1000K Model Selection from Performance Data

10:1 RATIO (optional)

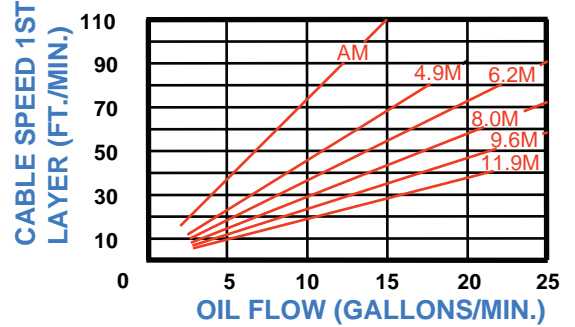
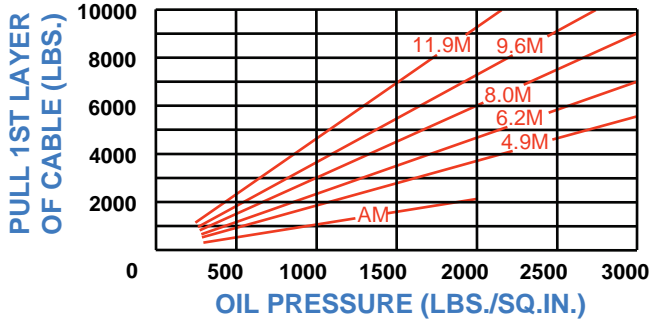

20:1 RATIO (standard)

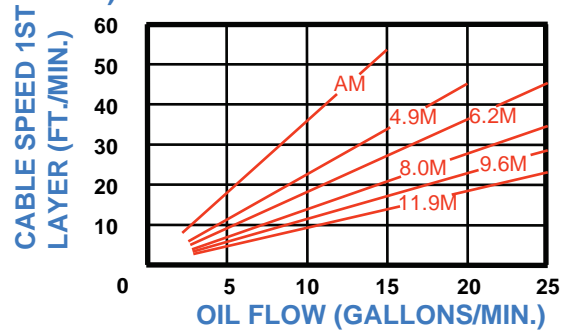
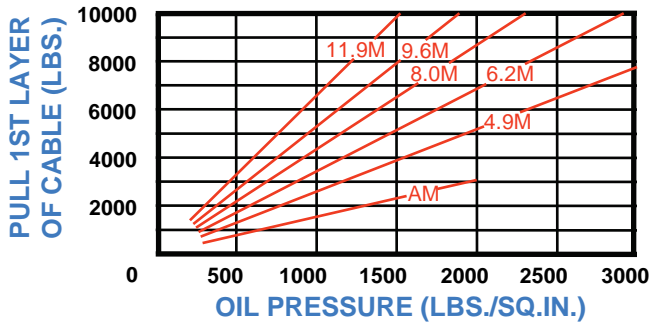

27:1 RATIO (optional)

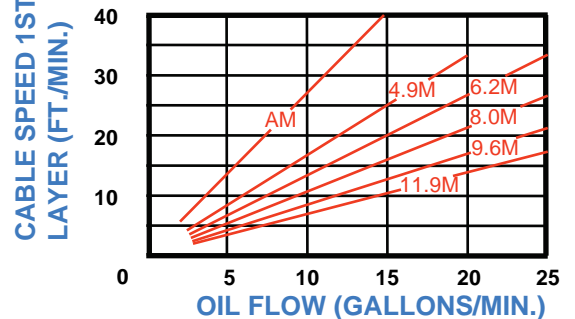
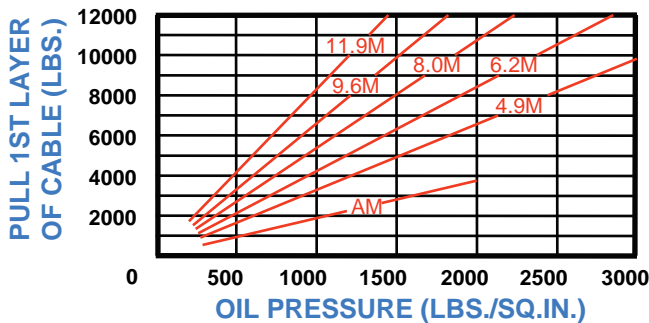

40:1 RATIO (optional)

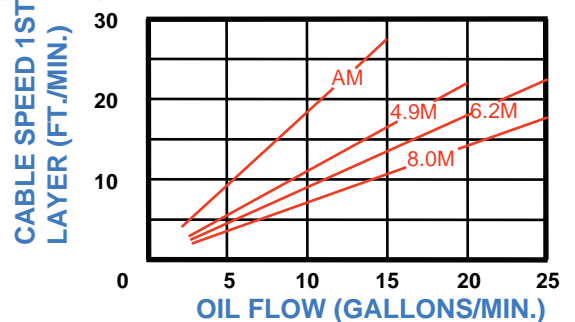
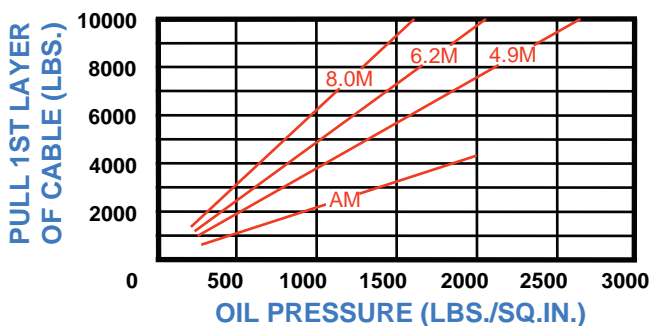

Dimensional Drawings

1000K Series With S8 and L8 Drum
Base Mount Model - Direct Drive

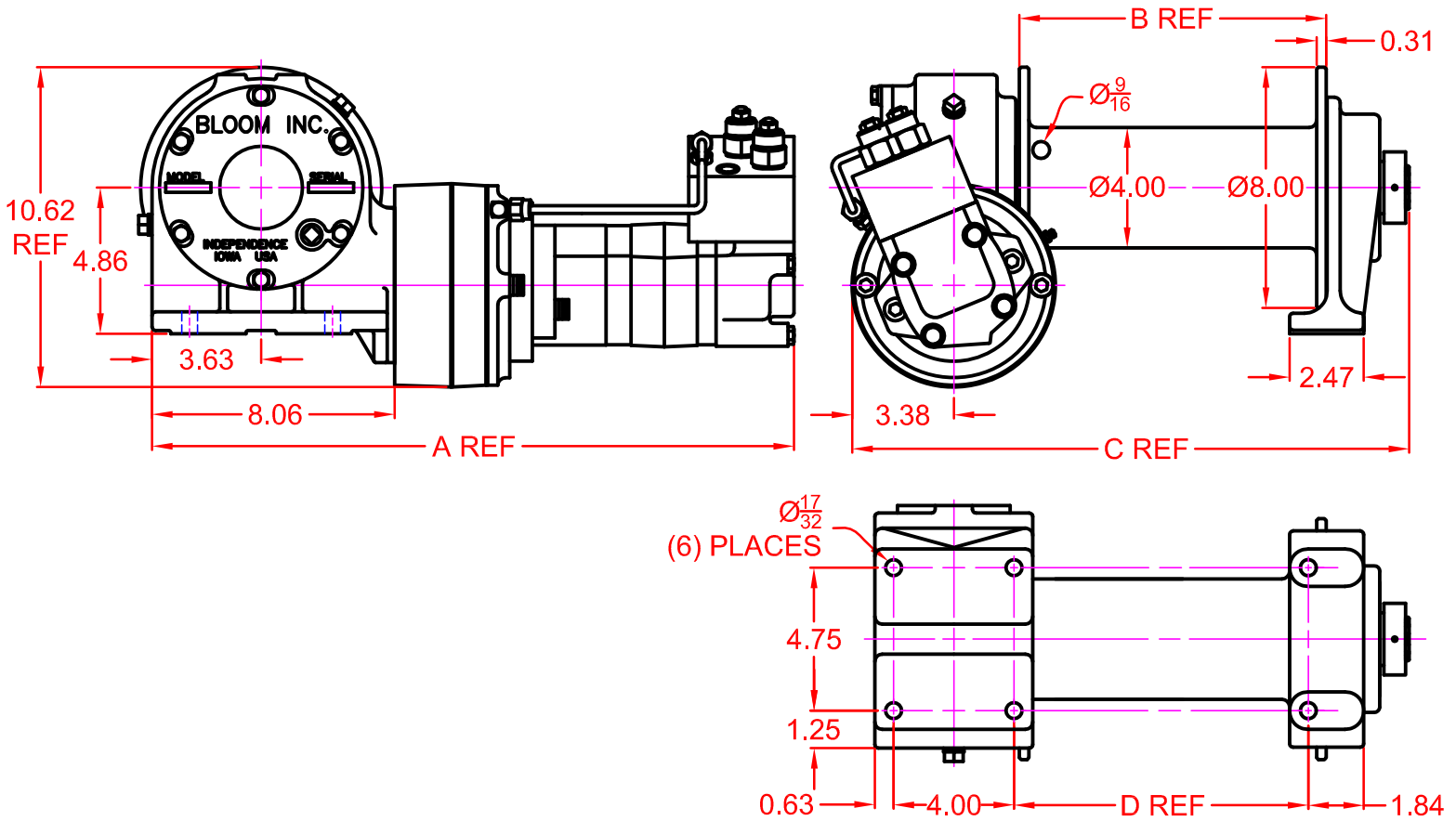

MOTOR DESIGNATION	AM	4.9M	6.2M	8.0M	9.6M	11.9M
A DIMENSION	18.10	19.80	20.07	20.32	20.32	20.59
DRUM DESIGNATION	WINCH DIMENSION					
	B	C		D		
	S8	7.19	15.16	6.69		
L8	10.19	18.16	9.69			

Bloom Manufacturing Inc.

Dimensional Drawings

1000K Series With XL10, XL12 and XL14 Drum
Base Mount Model - Direct Drive

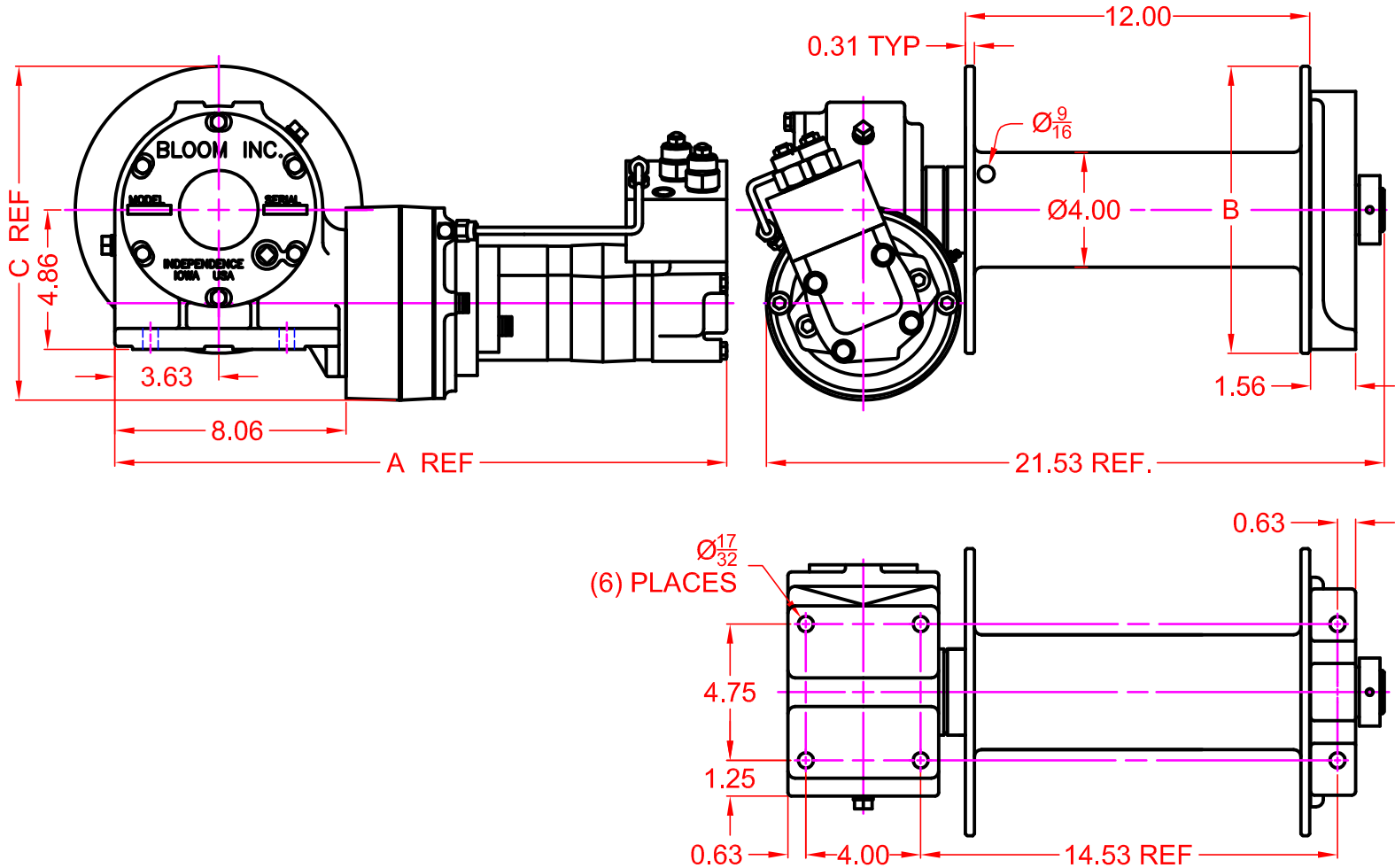

MOTOR DESIGNATION	AM	4.9M	6.2M	8.0M	9.6M	11.9M
A DIMENSION	18.10	19.89	20.07	20.32	20.32	20.32
DRUM DESIGNATION	XL10		XL12		XL14	
B DIMENSION	10		12		14	
C DIMENSION	11.62		12.62		13.62	

Bloom Manufacturing Inc.



Correct choice of Directional Control Valves for Lift-Safe® Winches

All **Lift-Safe®** Winches require a **Motor Spool Control Valve**.

That is the valve's work ports are **open** to tank in neutral position.

*Winches require ridged mounting plate.
See owner's manual for information about proper mounting plate thickness or call Bloom Sales Engineer at factory

WARNING!

Goods are not intended for use in the moving or lifting of persons!

The winches described herein are neither designed nor intended for use or application to equipment used in the lifting or moving of persons and it is understood that all such use shall be at the sole risk of the user.

The cable clamps on winches are not designed to hold rated loads. A minimum of 5 wraps of cable must be left on drum barrel to guarantee holding of rated load.

Applications of winch where life would be endangered by any event are not recommended.



BLOOM Manufacturing Inc.
Winch Division

1443 220th Street,, Independence, Iowa 50644

FAX 319-827-1140 PHONE 319-827-1139

www.bloommfg.com

©Copyright 2010 Bloom Mfg. Inc.