

Series 800HC

HYDRAULIC CABLE WINCHES



*"Quality Since
1910"*

The rugged construction and versatility of the **800HC Series** makes it adaptable to a wide range of applications. The **800HC Series** winches are equipped with a sliding clutch to allow free-spooling of the drum for industrial pulling applications including rear of cab and front mounting on ½ to 1 ½ ton trucks, flat bed trailers, material handling, mining and logging operations, air freight pullers, off road tractors, aboard ships and boats. 800HC Series may be ordered galvanized.



**UP TO 8,000 LBS.
CAPACITY**

Bloom Hydraulic Cable Winches – Standard Features

- | | |
|----------------------|--|
| MOTOR BRAKE | - Spring applied hydraulic release motor brake automatically holds load when hydraulic pressure is released. Utilizes a Double counter balance valve making it ideal for high speed Pulling Application. |
| GEAR CASE | - Made of high strength cast iron. Completely sealed for oil enclosed operation and to keep dirt out. |
| WORM SHAFT | - One piece alloy steel hardened and ground for extra durability. Compact design allows hydraulic motor to be coupled directly to worm. |
| WORM GEAR | - High tensile aluminum-nickel alloy bronze. Optimum lead and pressure angles transmit maximum power to the drum. |
| GEAR RATIO | - 20:1 standard, 10:1 optional ratios provide optimum efficiency in power and speed. |
| BEARINGS | - Worm gear and worm shaft run on tapered roller bearings. Outer end housing has sealed ball bearing. |
| DRUM SHAFT | - 1-1/4" diameter heat-treated alloy steel minimum tensile strength 150,000 psi. |
| CABLE DRUM | - Tough all steel construction resists breakage or warping. |
| CLUTCH OPTION | - 800HC Series winches comes equipped with heat-treated dog type clutch to provide free-spooling of the winch drum. Positive lock-in and lock-out. |



www.bloommfg.com

BLOOM

Manufacturing Inc.

Winch Division

"Custom Engineered Solutions"

*Lifting
Pulling
Hoisting*

Toll Free Number: 1-800-394-1139

1443 220th Street, Independence, Iowa 50644 • FAX: 319-827-1140 • PHONE: 319-827-1139

800HC Series

Model Selection from Performance Data



"Quality Since
1910"

MODEL EXAMPLE: **8H-3.0T-L8-C-10-LP**

Gear Case Mounting
8H = 800HC Series With 1-1/2" Drum Shaft

Low Profile Mounting
(specify with or without
mounting angles)

Hydraulic Motor Designation
3.0T, 6.2T

Gear Ratios
10:1, 20:1

Drum Sizes
S, S8 with 3.5" Core
L, L8 with 4" Core

Clutch
Designation
(Do not use clutch model for
lifting Applications)

(8H) Indicates winch series with 1-1/4" drum shaft.

(3.0T) Designates hydraulic motor. Motor size is determined from motor performance charts. All motors come with spring applied hydraulic release motor brake.

(L8) select drum size from chart below:

DRUM CAPACITY

CABLE DIAMETER (IN.)	1/4	5/16	3/8	7/16	1/2
DRUM "S" CAPACITY (FT.)	120	70	45	30	25
DRUM "S8" CAPACITY (FT.)	260	160	105	75	55
DRUM "L" CAPACITY (FT.)	175	105	65	45	30
DRUM "L8" CAPACITY (FT.)	390	240	160	110	80

(C) Designates 1000HC Series winch with dog type clutch for free - spooling drum.

(10) Indicates gear ratio. 10:1 is standard. 20:1.

(LP) Design low profile mounting on 800HC Series winches. However, it is necessary on all low profile whether the winch is to be supplied "with angles" or "less angles".

Series 800HC



Bloom Hydraulic Cable Winches Model Selection from Performance Data

*"Quality Since
1910"*

10:1 RATIO (optional)

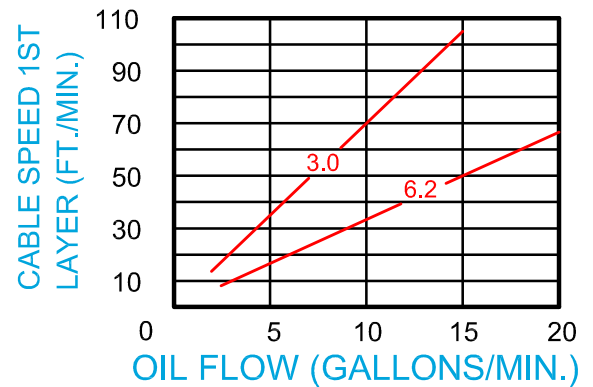
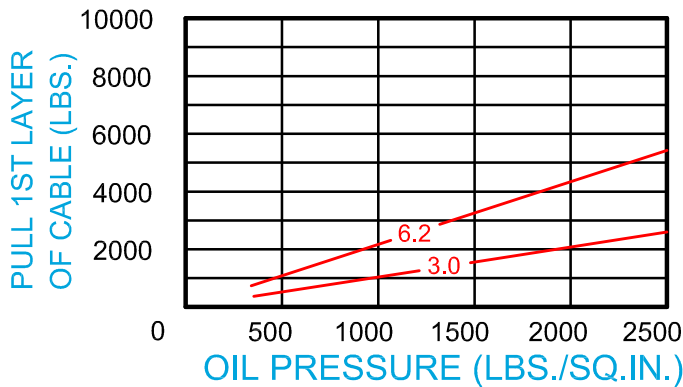

20:1 RATIO (standard)

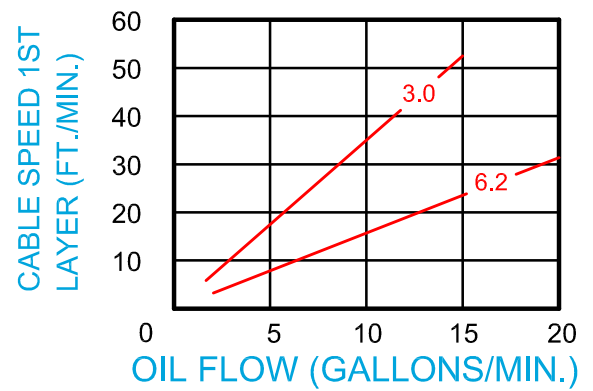
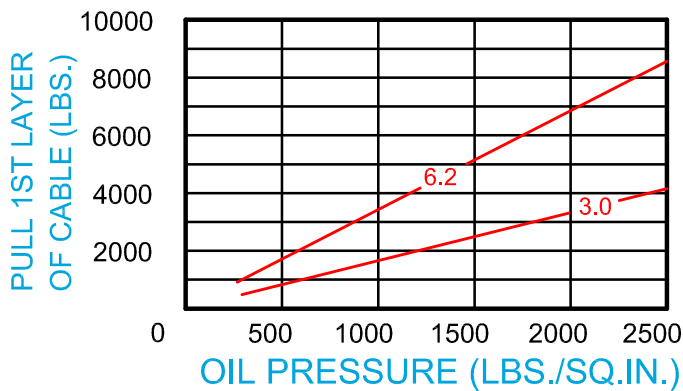



“Quality Since
1910”

Dimensional Drawings

Base Mount Model - Clutch Drive
800H Series With S, S8, L and L8 Drum

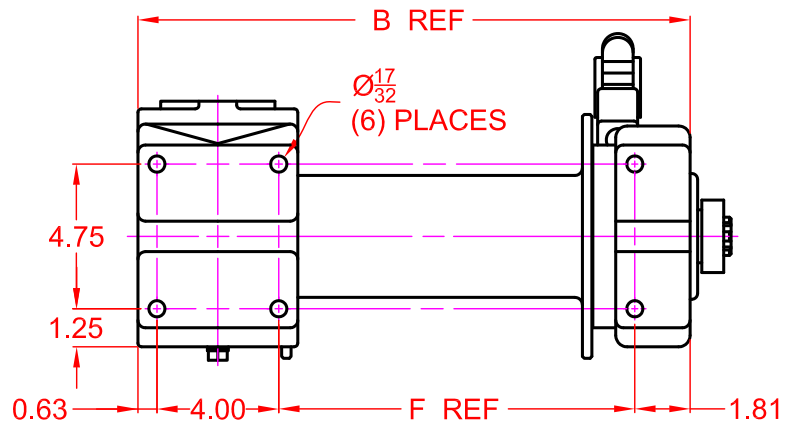
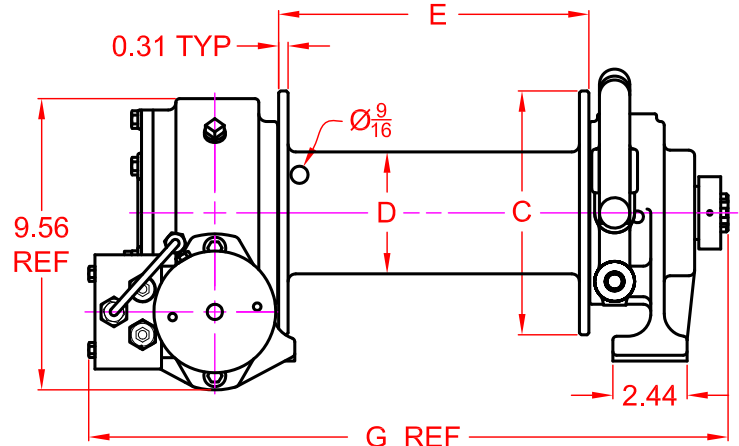
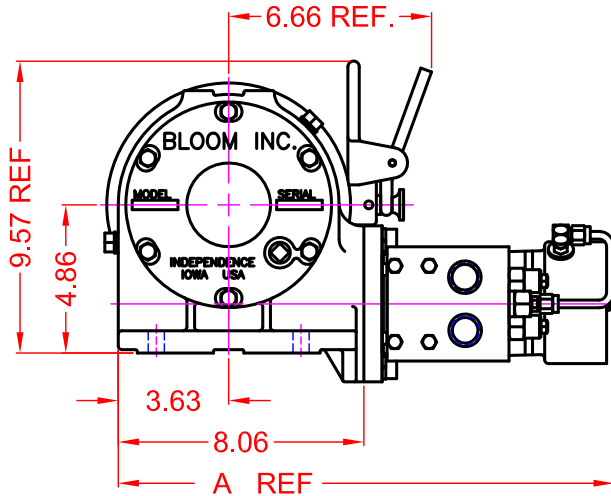

MOTOR DESIGNATION	3.0	6.2
A DIMENSION	15.91	16.28

DRUM DESIGNATION	WINCH DIMENSION					
	B	C	D	E	F	G
S	15.12	6	3.50	7.19	8.69	17.98
S8	15.12	8	4	7.19	8.69	17.98
L	18.12	6	3.50	10.19	11.69	20.98
L8	18.12	8	4	10.19	11.69	20.98

Motor Spool Valve – Work Ports are **open** to tank in neutral position

Use on all winches that use Counter Balance Valves to hold load.

Some winches may use a combination of CB Valve and Hydraulic Brake.

*Winches require ridged mounting plate.

See owner's manual for information about proper mounting plate thickness or call Bloom Sales Engineer at factory.

WARNING!

Goods are not intended for use in the moving or lifting of persons!

The winches described herein are neither designed nor intended for use or application to equipment used in the lifting or moving of persons and it is understood that all such use shall be at the sole risk of the user.

The cable clamps on winches are not designed to hold rated loads. A minimum of 5 wraps of cable must be left on drum barrel to guarantee holding of rated load.

Applications of winch where life would be endangered by any event are not recommended.



BLOOM Manufacturing Inc.

Winch Division

1443 220th Street, Independence, Iowa 50644

FAX 319-827-1140 PHONE 319-827-1139

www.bloommfg.com