

BLOOM™ WINCH



"Quality Since
1910"

Series 4200KC

HYDRAULIC PLANETARY CABLE WINCHES

4200KC Series hydraulic winches are designed for a wide range of applications. **4200KC Series** clutch drive winches are used for industrial pulling applications, fishing boats, marine craft, drill rigs, small cranes, factory material handling and rear load waste handlers. The **4200KC Series** clutch drive winches are equipped with a sliding clutch to allow free-spooling of the drum for pulling applications including factory material handling, mining and logging equipment, flat bed trailers, air freight pullers and off the road tractors. The **4200KC Series** is equipped with hydraulic Fail-Safe Brake.

UP TO 21,000 LBS.
CAPACITY

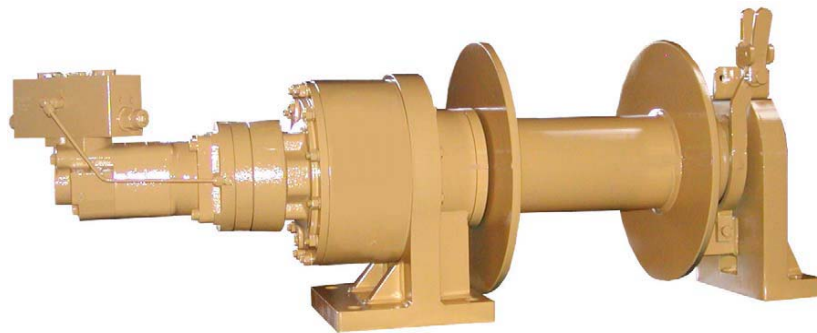

Bloom™ Hydraulic Cable Winches – Standard Features

- BRAKE** - **DUET-SAFE® Double Action Braking System** combines a powerful spring applied, hydraulic released brake with a double counter balance brake valve to automatically hold loads when hydraulic pressure is released and control speed during lowering operations. Winch is ideal for high speed pulling applications or wherever load holding is critical.
- GEAR CASE** - Made of high strength steel. Completely sealed for oil enclosed operation and to keep dirt out.
- PLANETARY GEAR** - High Efficiency Double Reduction - Rugged - Built to Last.
- GEAR RATIO** - 27:1 standard.
- BEARINGS** - Drum Shaft is supported by three heavy duty oil lubricated ball bearings in gear case and end housing.
- DRUM SHAFT** - 4" diameter heat-treated alloy steel
- CABLE DRUM** - Tough all steel construction resists breakage or warping.
- CLUTCH** - 4200KC Series winches comes equipped with heat-treated dog type clutch to provide free-spooling of the winch drum. Positive lock-in and lock-out.



www.bloommfg.com

BLOOM
Manufacturing Inc.
Winch Division

"Custom Engineered Solutions"

Lifting
Pulling
Hoisting

Toll Free Number: 1-800-394-1139

1443 220th Street,, Independence, Iowa 50644 • FAX: 319-827-1140 • PHONE: 319-827-1139

BLOOM™ WINCH



"Quality Since
1910"

4200KC Series Model Selection from Performance Data

MODEL EXAMPLE: 42K-15.0M-L2012-C-27

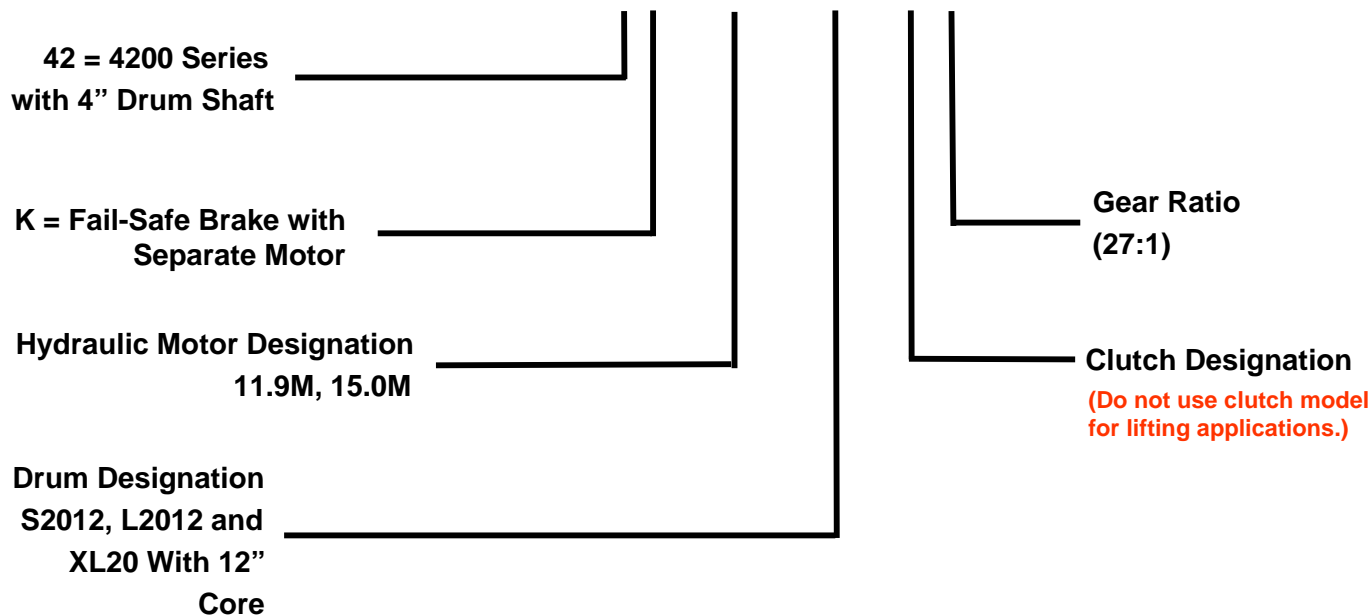

(42K) Indicates a 4200K Series winch with 4" drum shaft, and standard fail-safe brake.

(15.0M) Designates hydraulic motor. Motor size is determined from motor performance charts. All motors come complete with attached double counter balanced valve.

(L2012) Drum designation.

(C) Designates 4200KC Series winch with dog type clutch for free - spooling drum

(27) Indicates gear ratio. 27:1 is standard.

BLOOM™ WINCH



4200KC Series W/ 12" Core Model Selection from Performance Data

"Quality Since
1910"

27:1 RATIO

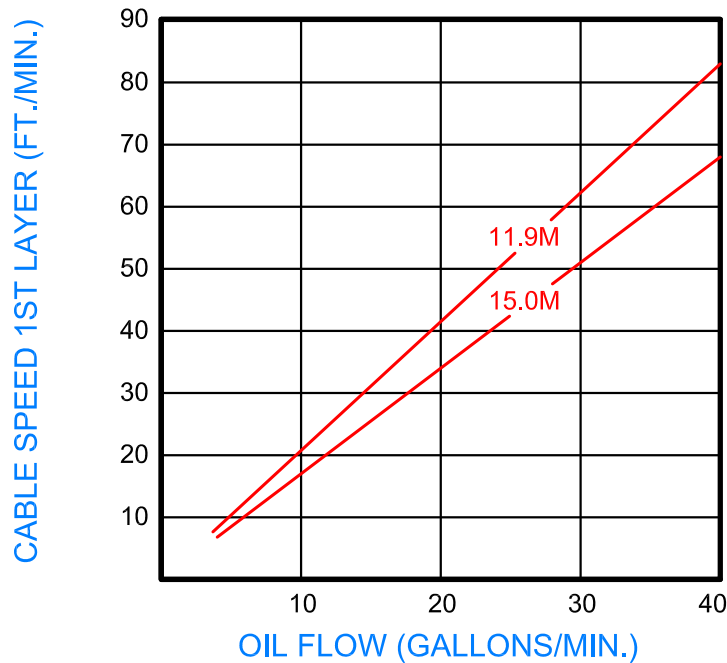
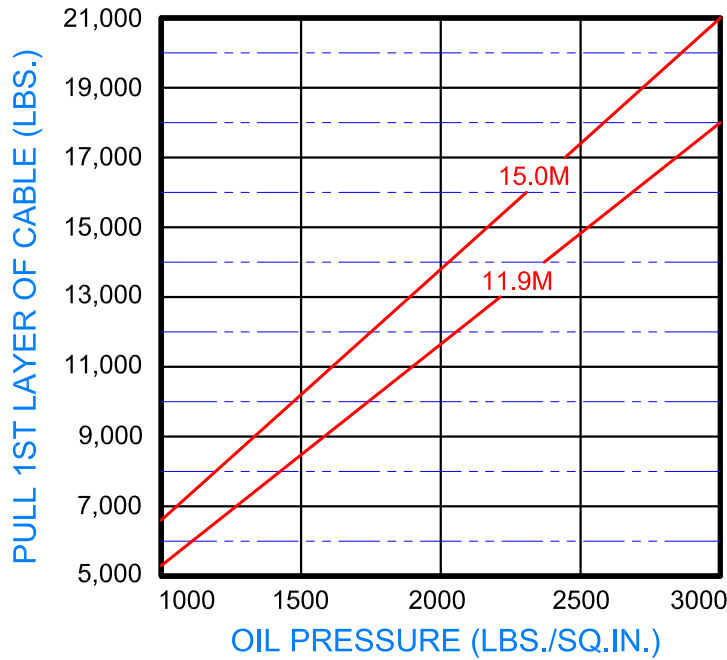



"Quality Since
1910"

BLOOM™ WINCH

Dimensional Drawings

4200KC Series W/ 12" Core
Base Mount Model - Clutch Drive

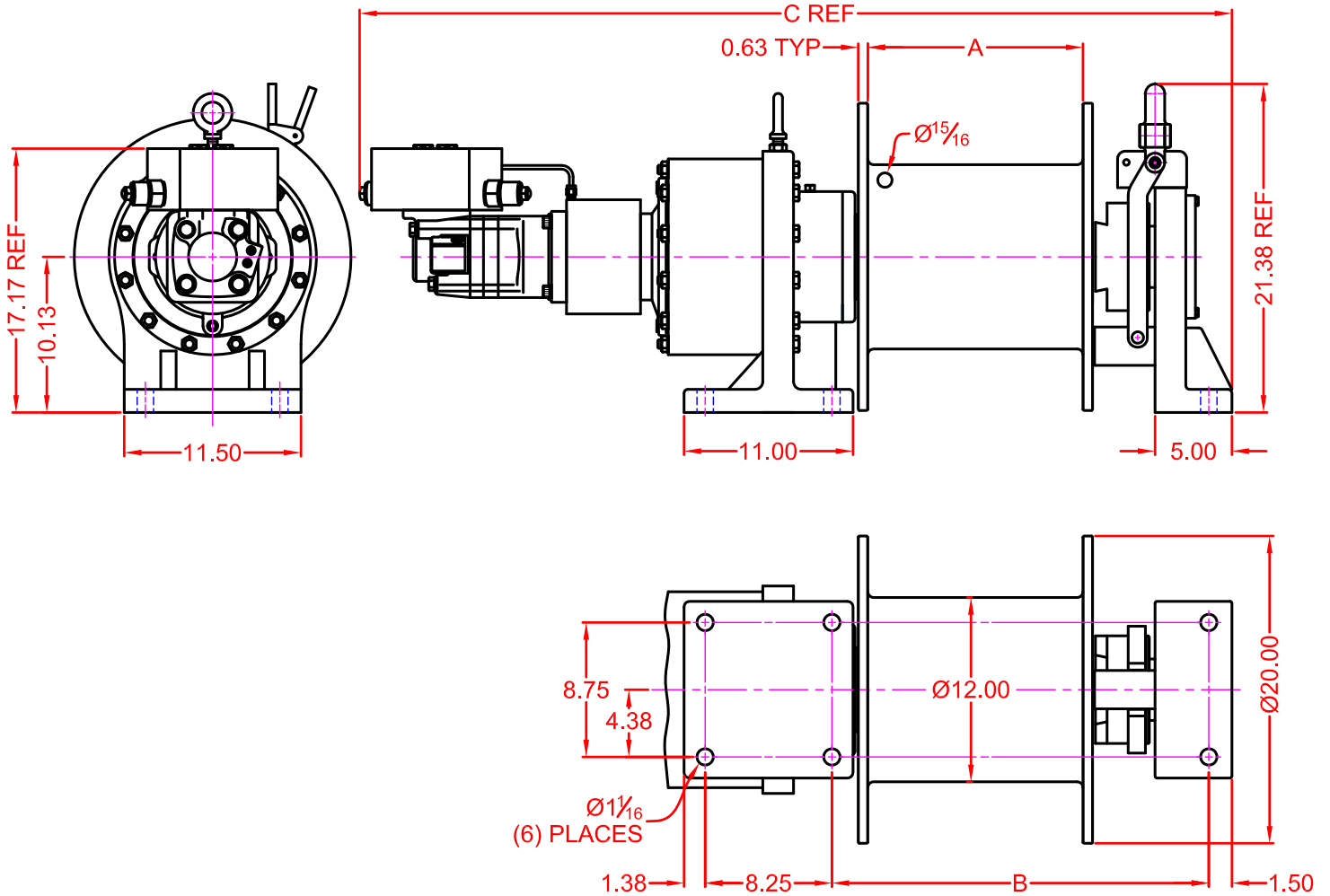

WINCH DIMENSION	DRUM DESIGNATION		
	S2012C	L2012C	XL2012C
A DIMENSION	8	14	20
B DIMENSION	18.52±0.06	24.52±0.06	30.52±0.06
C DIMENSION	50.75	56.75	62.75

CABLE SIZE (INCH)	CABLE CAPACITY (FT.)		
	S2012C DRUM	L2012C DRUM	XL2012C DRUM
Ø3/4"	150	260	375
Ø7/8"	95	165	235

BLOOM™ WINCH

Correct choice of Directional Control Valves for Bloom Winches

Winches require a **Motor Spool Control Valve**.
That is the valve's work ports are **open** to tank in neutral position.

*Winches require ridged mounting plate.
See owner's manual for information about proper mounting
plate thickness or call Bloom Sales Engineer at factory

WARNING!

Goods are not intended for use in the moving or lifting of
persons!

The winches described herein are neither designed nor intended
for use or application to equipment used in the lifting or moving of
persons and it is understood that all such use shall be at the sole
risk of the user.

The cable clamps on winches are not designed to hold rated
loads. A minimum of 5 wraps of cable must be left on drum barrel
to guarantee holding of rated load.

Applications of winch where life would be endangered by any
event are not recommended.



BLOOM Manufacturing Inc.

Winch Division

1443 220th Street, Independence, Iowa 50644

FAX 319-827-1140 PHONE 319-827-1139

www.bloommfg.com

©Copyright 2010 Bloom Mfg. Inc.