

# Series 1400

## **HYDRAULIC CABLE WINCHES**



*"Quality Since  
1910"*

The rugged construction and versatility of the **1400 Series** makes it adaptable to a wide range of applications. 1400 Series direct drive winches are used for lifting or pulling applications such as construction lifting equipment, fishing, other marine craft and cranes.

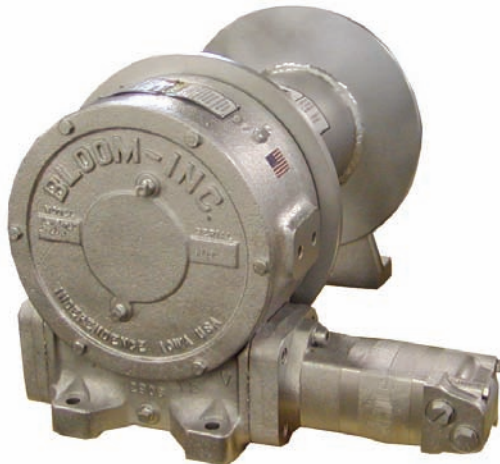

1400 Series Galvanized model Shown  
Standard Finish is Painted  
Low Profile or Base Mount Available

**Up To 15,000 LBS.  
CAPACITY**

## Bloom Hydraulic Cable Winches – Standard Features

- GEAR CASE** - Made of high strength cast iron. Completely sealed for oil enclosed operation and to keep dirt out.
- WORM SHAFT** - One piece alloy steel hardened and ground for extra durability. Seal on worm allows motor to be removed without draining oil.
- WORM GEAR** - High tensile aluminum-nickel alloy bronze cast on high strength ductile iron hub. Optimum lead and pressure angles transmit maximum power to the drum.
- GEAR RATIO** - 25:1 standard & 12.5:1 optional ratios provide optimum efficiency in power and speed.
- BEARINGS** - Worm gear and worm shaft run on tapered roller bearings. Outer end housing has a grease zerk for lubricating the bronze bushing.
- DRUM SHAFT** - 2-1/4" diameter heat treated alloy steel minimum tensile strength 150,000 psi.
- CABLE DRUM** - Tough all steel construction resists breakage or warping.

**CAUTION:**

This winch model does not include any kind of holding brake. If your application requires a holding brake choose 1400K series winches with hydraulic fail-safe brakes.



[www.bloommfg.com](http://www.bloommfg.com)

# **BLOOM**

**Manufacturing Inc.**

**Winch Division**

**"Custom Engineered Solutions"**

**Lifting  
Pulling  
Hoisting**

Toll Free Number: 1-800-394-1139

1443 220<sup>th</sup> Street,, Independence, Iowa 50644 • FAX: 319-827-1140 • PHONE: 319-827-1139

# 1400 Series

## Model Selection from Performance Data



*"Quality Since  
1910"*

**MODEL EXAMPLE: 14-6.2-L14-RH-25-LP**

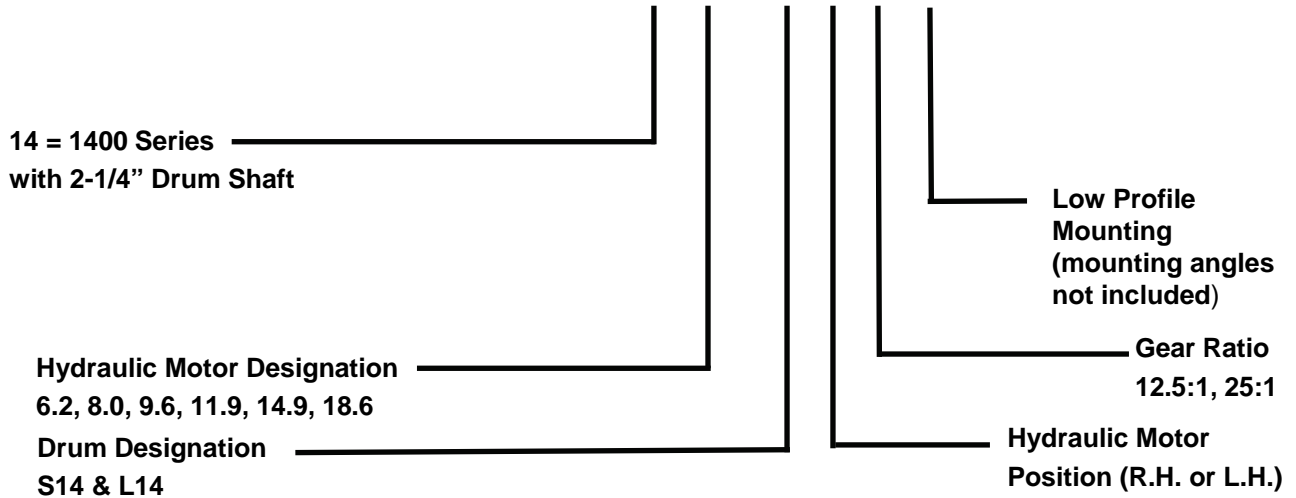

(14) Indicates a 1400 Series winch with 2 1/4" drum shaft.

(6.2) Designates hydraulic motor used. To select proper motor size, use performance data chart.

(L14) Drum designation.

## DRUM CAPACITY

CABLE DIAMETER (IN.)	5/16	3/8	7/16	1/2	9/16	5/8
DRUM "S14" CAPACITY (FT.)	615	400	300	225	160	115
DRUM "L14" CAPACITY (FT.)	1100	712	517	409	295	200

(RH) Hydraulic motor may be placed on either side of the gear case. Specify right hand (RH) or left hand (LH) as viewed looking at gear case cover. Right hand is standard.

(25) Indicates gear ratio. 25:1 is standard. ( 12.5:1 Optional )

(LP) Designates low profile mounting. It is necessary on all low profile whether the winch is to be supplied "with angles" or "less angles".

# Series 1400

## Bloom Hydraulic Cable Winches Model Selection from Performance Data

12.5:1 RATIO (optional)

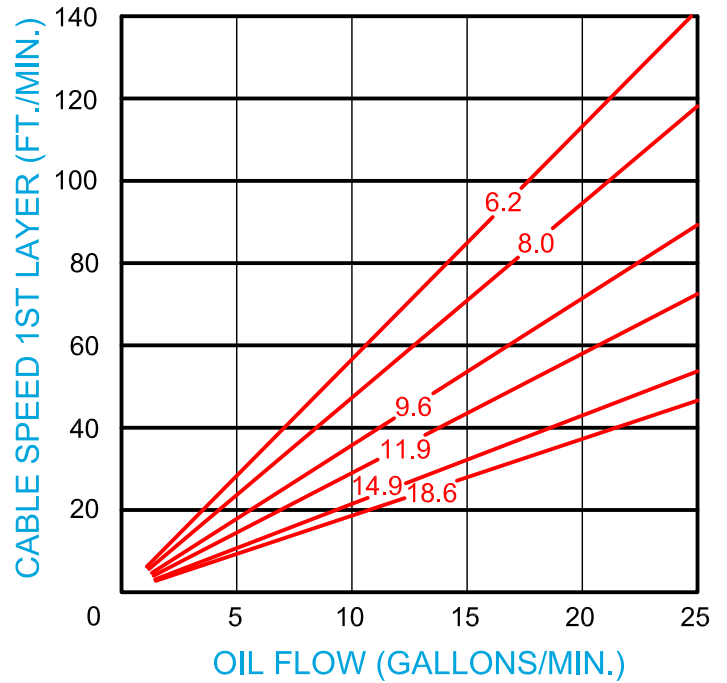
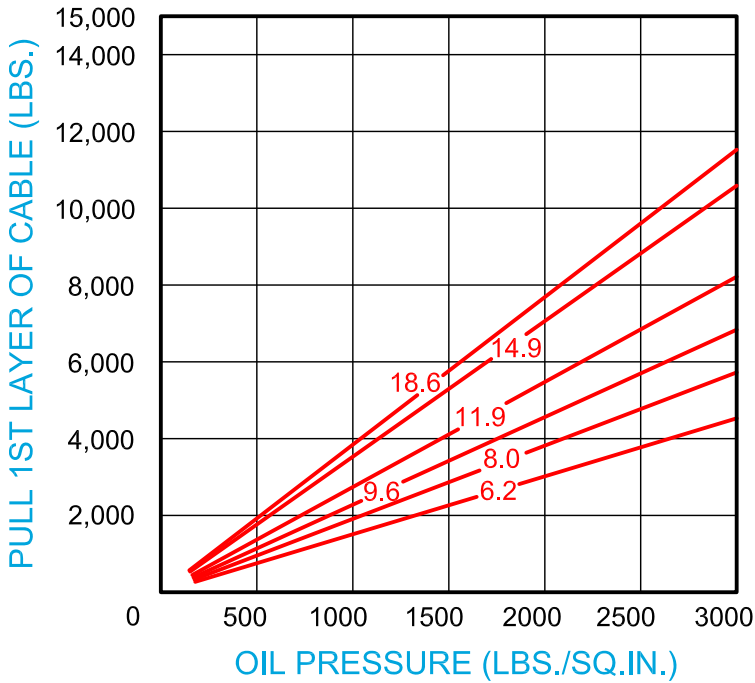

25:1 RATIO (standard)

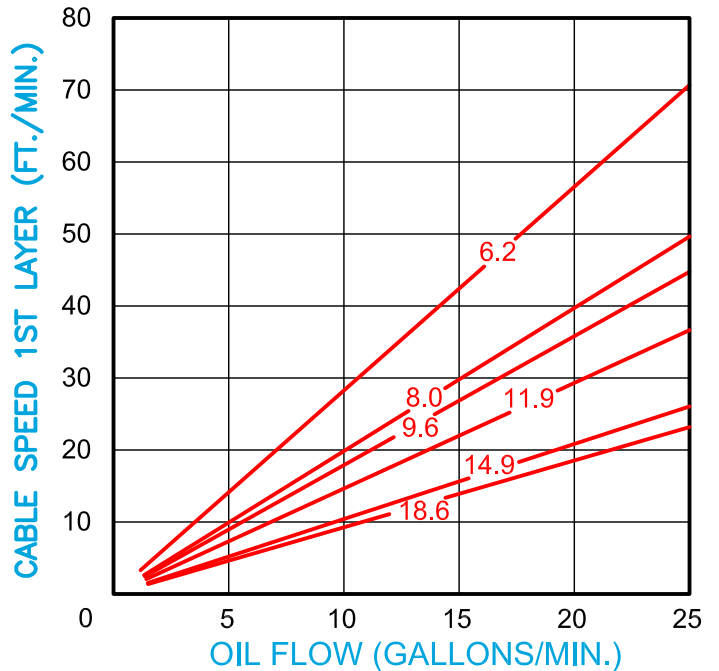
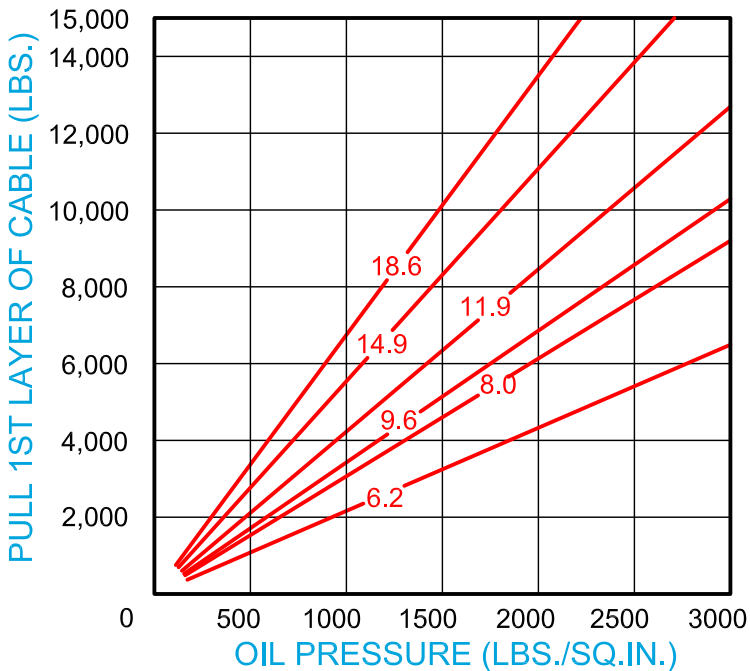



# Dimensional Drawings

Series 1400 With S14 & L14 Drums  
Base Mount Model - Direct Drive

"Quality Since  
1910"

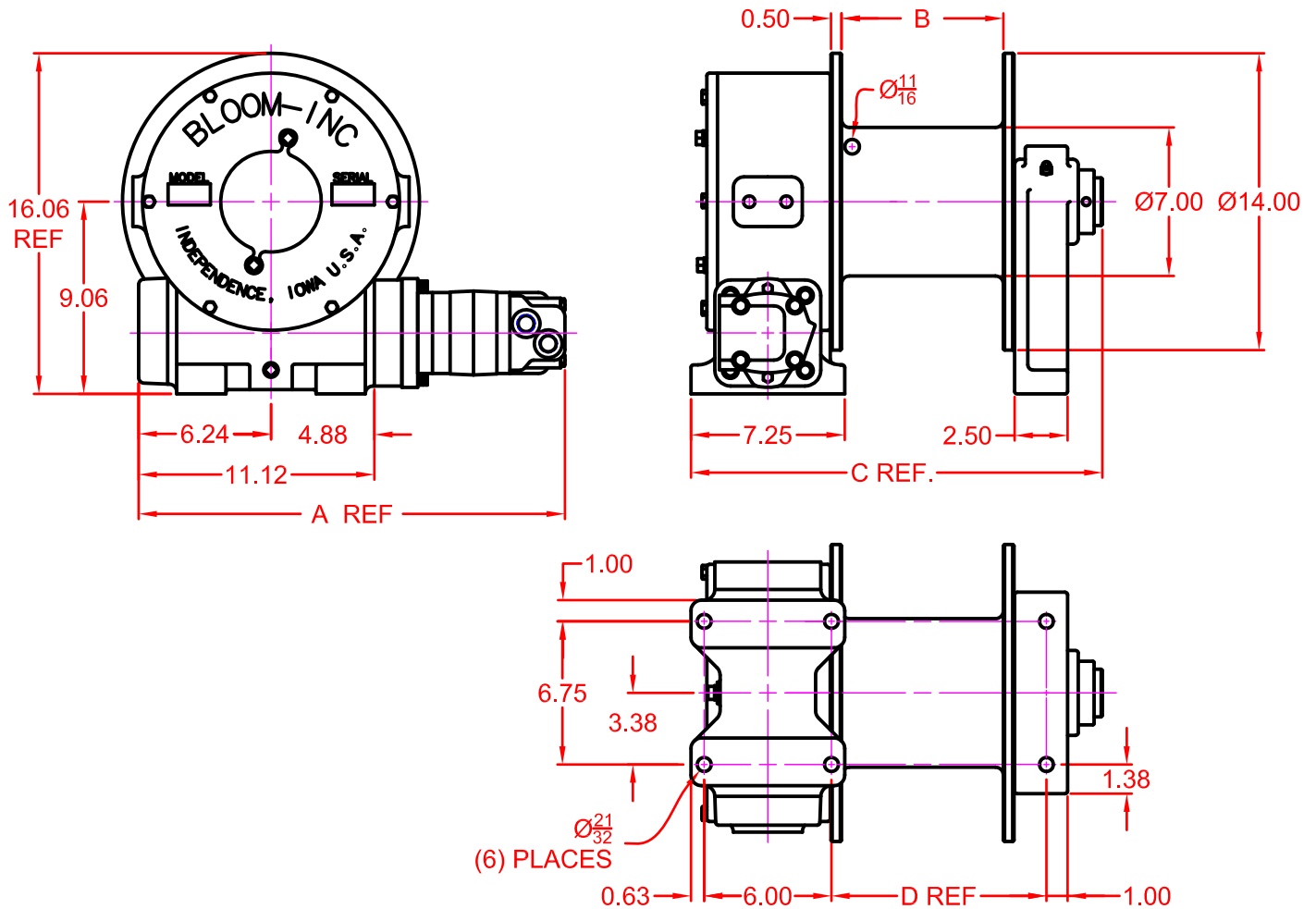

MOTOR DESIGNATION	6.2	9.6	11.9	18.6
A DIMENSION	19.86	20.11	20.38	21.18

DRUM DESIGNATION	B	C	D
S14	7.63	19.40	10.14
L14	13.63	25.46	16.14

CABLE DIAMETER (IN.)	5/16	3/8	7/16	1/2	9/16	5/8
DRUM "S14" CAPACITY (FT.)	615	400	300	225	160	115
DRUM "L14" CAPACITY (FT.)	1100	712	517	409	295	200

**Tandem Center Spool Valve** – Work Ports are **blocked** in neutral position

Use on all winches that use motor only to hold load.

\*Winches require ridged mounting plate.  
See owner's manual for information about proper mounting plate thickness or call Bloom Sales Engineer at factory

## WARNING!

Goods are not intended for use in the moving or lifting of persons!

The winches described herein are neither designed nor intended for use or application to equipment used in the lifting or moving of persons and it is understood that all such use shall be at the sole risk of the user.

The cable clamps on winches are not designed to hold rated loads. A minimum of 5 wraps of cable must be left on drum barrel to guarantee holding of rated load.

Applications of winch where life would be endangered by any event are not recommended.



# BLOOM Manufacturing Inc.

## Winch Division

1443 220<sup>th</sup> Street., Independence, Iowa 50644

FAX 319-827-1140 PHONE 319-827-1139

[www.bloommfg.com](http://www.bloommfg.com)