

BLOOM™ WINCH



"Quality Since
1910"

Series 1400KC

HYDRAULIC CABLE WINCHES

The rugged construction and versatility of the **1400KC Series** makes it adaptable to a wide range of applications. The **1400KC Series** winches are equipped with a sliding clutch to allow free-spooling of the drum for pulling applications such as trailers, mining, logging equipment and off road tractors. The **1400KC Series** is equipped with a hydraulic fail-safe brake.

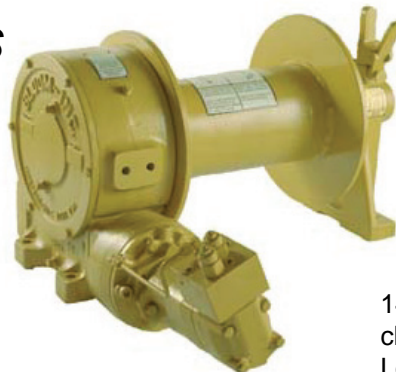

**Up To 15,000 LBS.
CAPACITY**

1400KC Series shown with
clutch and hydraulic brake
Low Profile or Base Mount
Available

Bloom™ Hydraulic Cable Winches – Standard Features

- | | |
|-------------------|--|
| BRAKE | - DUET-SAFE® Double Action Braking System combines a powerful spring applied, hydraulic released brake with a double counter balance brake valve to automatically hold loads when hydraulic pressure is released and control speed during lowering operations. Winch is ideal for high speed pulling applications or wherever load holding is critical. |
| GEAR CASE | - Made of high strength cast iron. Completely sealed for oil enclosed operation and to keep dirt out. |
| WORM SHAFT | - One piece alloy steel hardened and ground for extra durability. Seal on worm allows brake to be removed without draining oil. |
| WORM GEAR | - High tensile aluminum-nickel alloy bronze cast on high strength ductile iron hub. Optimum lead and pressure angles transmit maximum power to the drum. |
| GEAR RATIO | - 25:1 standard & 12.5:1 optional ratios provide optimum efficiency in power and speed. |
| BEARINGS | - Worm gear and worm shaft run on tapered roller bearings. Outer end housing has a grease zerk for lubricating the bronze bushing. |
| DRUM SHAFT | - 2-1/4" diameter heat-treated alloy steel minimum tensile strength 150,000 psi. |
| CABLE DRUM | - Tough all steel construction resists breakage or warping. |
| CLUTCH | - 1400C and 1400KC Series winches come with heat-treated dog type clutch to provide free-spooling of the winch drum. Positive lock-in and lock-out. |



www.bloommfg.com

BLOOM

Manufacturing Inc.

Winch Division

"Custom Engineered Solutions"

**Lifting
Pulling
Hoisting**

Toll Free Number: 1-800-394-1139

1443 220th Street,, Independence, Iowa 50644 • FAX: 319-827-1140 • PHONE: 319-827-1139

BLOOM™ WINCH



1400KC Series

Model Selection from Performance Data

"Quality Since 1910"

MODEL EXAMPLE: 14(K)-6.2M-L14-C-RH-25-LP

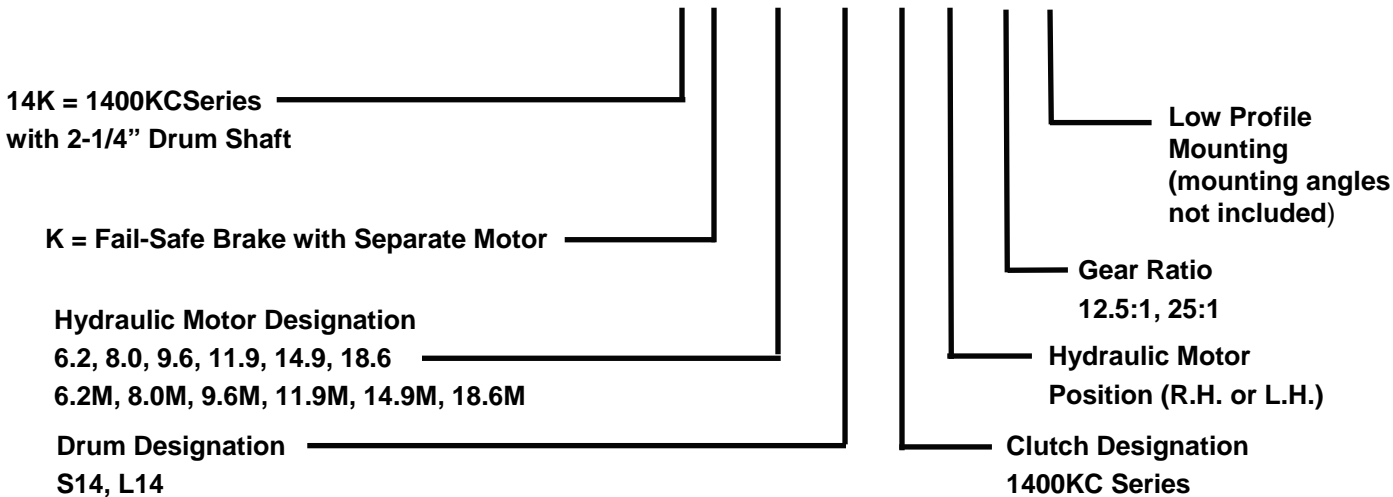

(14) Indicates a 1400C Series winch with 2 1/4" drum shaft.

(14K) Indicates a 1400KC Series winch with 2 1/4" drum shaft. The "K" indicates spring applied hydraulic released fail-safe brake.

(6.2M) Designates hydraulic motor used. 6.2M designates a manifold mount motor which is used in conjunction with fail-safe brake and includes counter balance valve. Fail-safe brake should be used in pulling application where positive load holding is required. To select proper motor size, use performance data chart. Hydraulic motors with out "M" designation have 7/8"-14 S.A.E. female ports. Counterbalance valve ports are 1-1/16"-12 S.A.E. female ports. Hydraulic pressure (P.S.I.) and flow rate (G.P.M.) must be known.

(L14) Drum designation.

DRUM CAPACITY

| CABLE DIAMETER (IN.) | 5/16 | 3/8 | 7/16 | 1/2 | 9/16 | 5/8 |
|---------------------------|------|-----|------|-----|------|-----|
| DRUM "S14" CAPACITY (FT.) | 615 | 400 | 300 | 225 | 160 | 115 |
| DRUM "L14" CAPACITY (FT.) | 1100 | 712 | 517 | 409 | 295 | 200 |

(KC) Designates 1400KC Series winch with dog type clutch for free - spooling drum.

(RH) Hydraulic motor may be placed on either side of the gear case. Specify right hand (RH) or left hand (LH) as viewed looking at gear case cover. Right hand is standard.

(25) Indicates gear ratio. 25:1 is standard. (12.5:1 Optional)

(LP) Designates low profile mounting. It is necessary on all low profile whether the winch is to be supplied "with angles" or "less angles".

BLOOM™ WINCH

Series 1400KC

Bloom Hydraulic Cable Winches Model Selection from Performance Data

12.5:1 RATIO (optional)

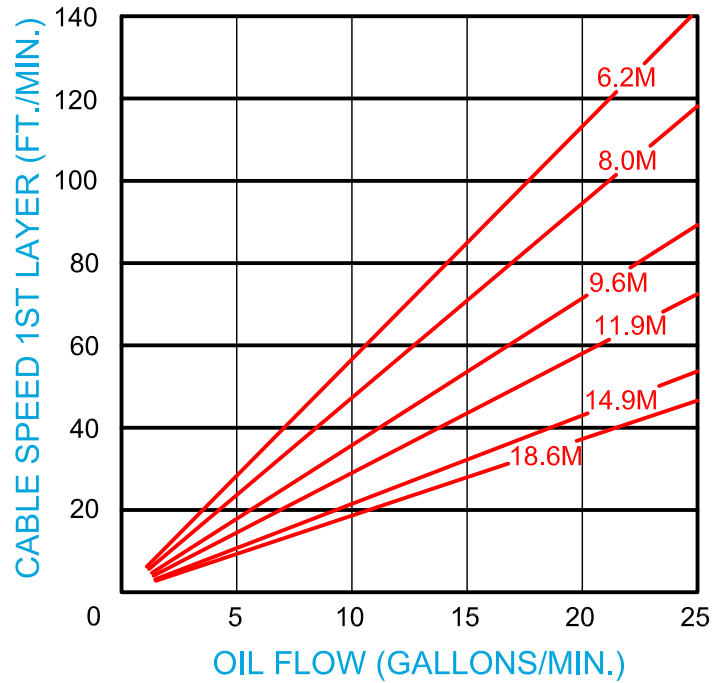
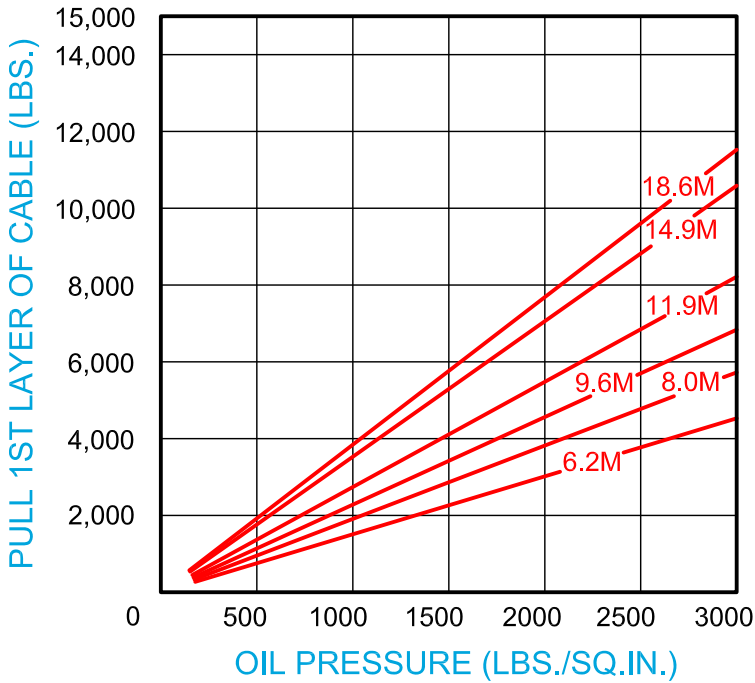

25:1 RATIO (standard)

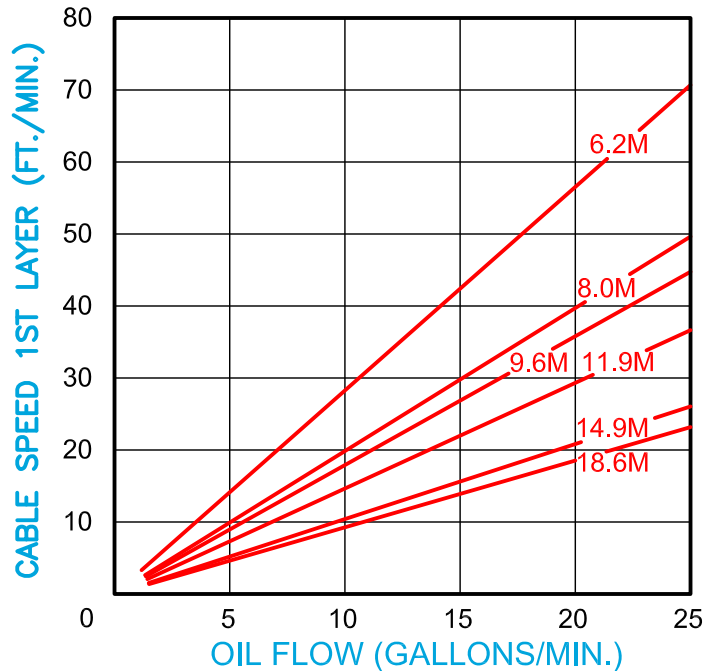
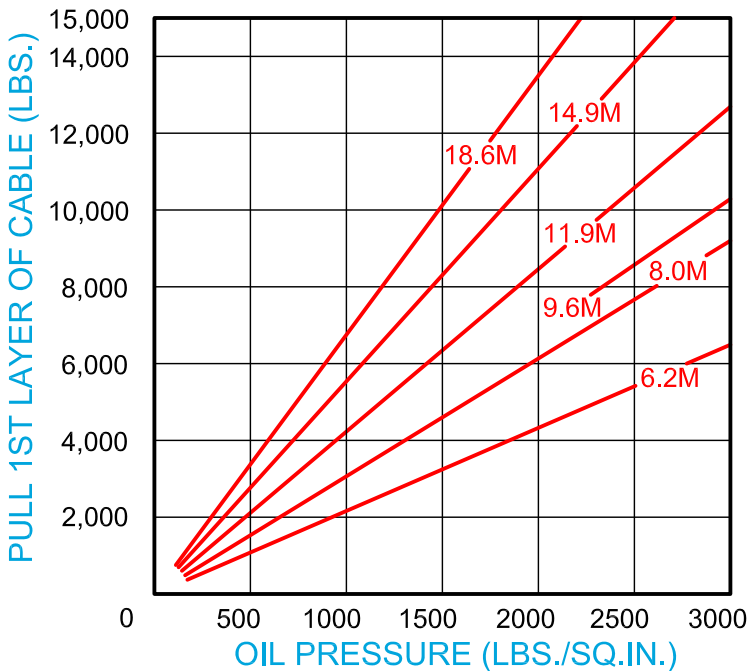



BLOOM™ WINCH

Dimensional Drawings

"Quality Since 1910"

Series 1400KC With S14 & L14 Drums
Base Mount Model - Clutch Drive

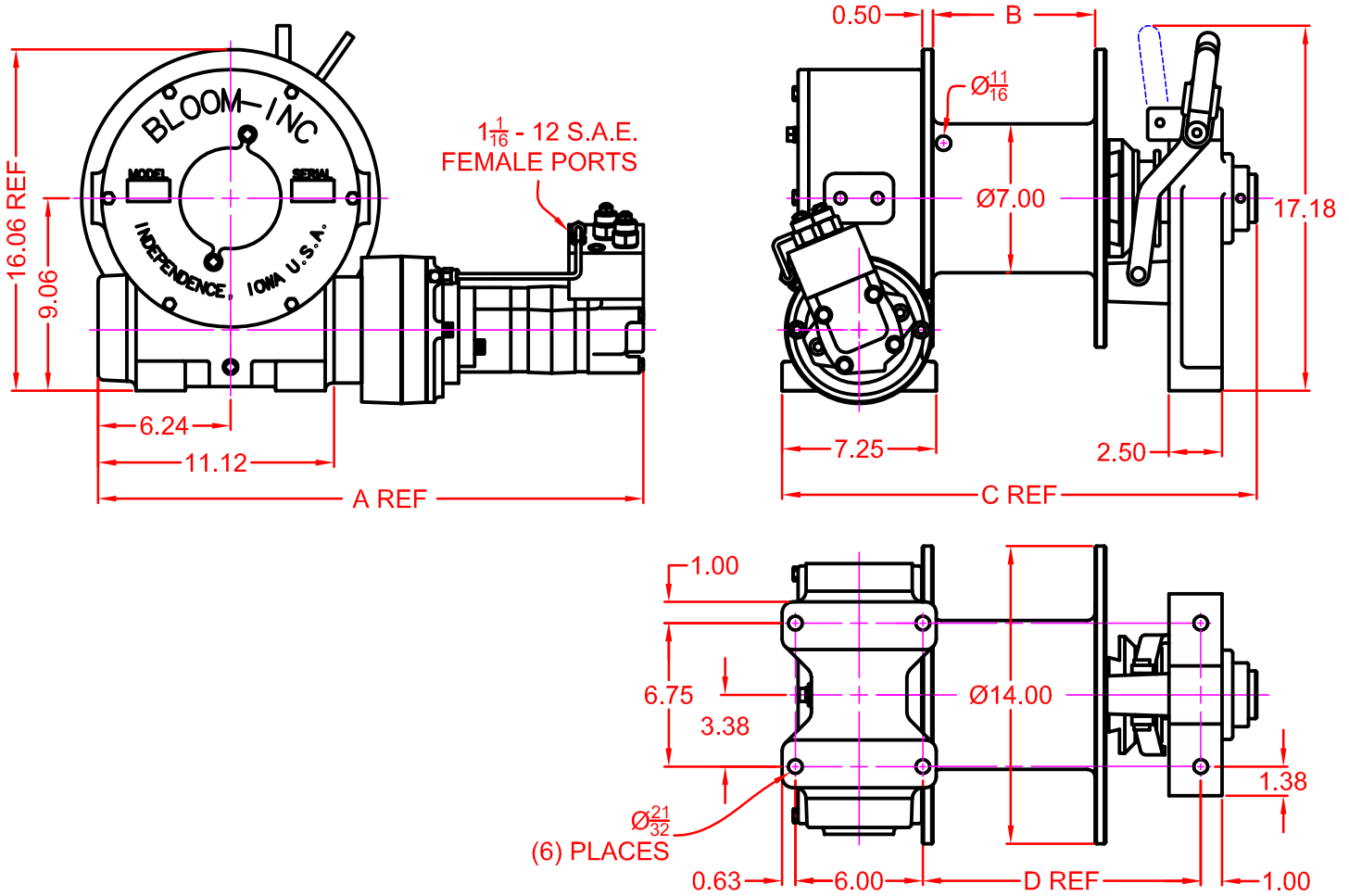

| | | | | |
|-------------------|-------|-------|-------|-------|
| MOTOR DESIGNATION | 6.2M | 9.6M | 11.9M | 18.6M |
| A DIMENSION | 24.42 | 24.67 | 24.94 | 25.74 |

| | | | |
|------------------|-------|-------|-------|
| DRUM DESIGNATION | B | C | D |
| S14 | 7.63 | 22.35 | 13.08 |
| L14 | 13.63 | 28.35 | 19.08 |

| | | | | | | |
|---------------------------|------|-----|------|-----|------|-----|
| CABLE DIAMETER (IN.) | 5/16 | 3/8 | 7/16 | 1/2 | 9/16 | 5/8 |
| DRUM "S14" CAPACITY (FT.) | 615 | 400 | 300 | 225 | 160 | 115 |
| DRUM "L14" CAPACITY (FT.) | 1100 | 712 | 517 | 409 | 295 | 200 |



BLOOM™ WINCH

Dimensional Drawings

“Quality Since
1910”

Series 1400KC With S14 & L14 Drums
Low Profile Model - Clutch Drive

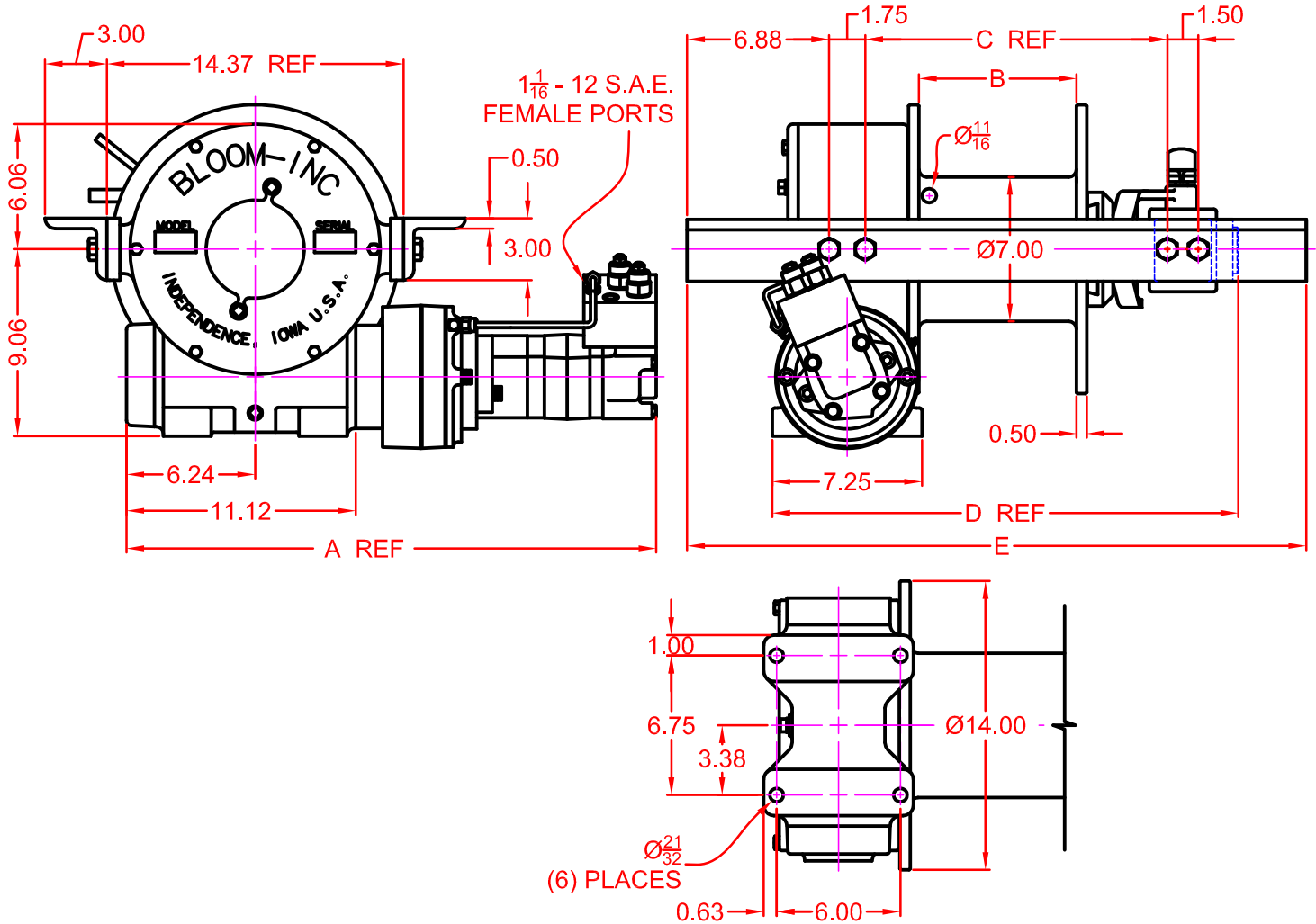

| | | | | |
|-------------------|-------|-------|-------|-------|
| MOTOR DESIGNATION | 6.2M | 9.6M | 11.9M | 18.6M |
| A DIMENSION | 24.42 | 24.67 | 24.94 | 25.74 |

| | | | | |
|------------------|-------|-------|-------|----|
| DRUM DESIGNATION | B | C | D | E |
| S14 | 7.63 | 14.64 | 22.58 | 30 |
| L14 | 13.63 | 20.64 | 28.58 | 36 |

| | | | | | | |
|---------------------------|------|-----|------|-----|------|-----|
| CABLE DIAMETER (IN.) | 5/16 | 3/8 | 7/16 | 1/2 | 9/16 | 5/8 |
| DRUM "S14" CAPACITY (FT.) | 615 | 400 | 300 | 225 | 160 | 115 |
| DRUM "L14" CAPACITY (FT.) | 1100 | 712 | 517 | 409 | 295 | 200 |

BLOOM™ WINCH

Correct choice of Directional Control Valves for Bloom Winches

Motor Spool Valve – Work Ports are **open** to tank in neutral position

Use on all winches that use Counter Balance Valves to hold load.

Some winches may use a combination of CB Valve and Hydraulic Brake.

*Winches require ridged mounting plate.

See owner's manual for information about proper mounting plate thickness or call Bloom Sales Engineer at factory.

WARNING!

Goods are not intended for use in the moving or lifting of persons!

The winches described herein are neither designed nor intended for use or application to equipment used in the lifting or moving of persons and it is understood that all such use shall be at the sole risk of the user.

The cable clamps on winches are not designed to hold rated loads. A minimum of 5 wraps of cable must be left on drum barrel to guarantee holding of rated load.

Applications of winch where life would be endangered by any event are not recommended.



BLOOM Manufacturing Inc.

Winch Division

1443 220th Street, Independence, Iowa 50644

FAX 319-827-1140 PHONE 319-827-1139

www.bloommfg.com

©Copyright 2010 Bloom Mfg. Inc.