

Series 1200WC



"Quality Since
1910"

HYDRAULIC CABLE WINCHES

The rugged construction and versatility of the **1200WC Series** makes it adaptable to a wide range of applications. The **1200WC Series** winches are equipped with a sliding clutch to allow free-spooling of the drum for pulling applications including rear of cab and front mounting on ½ to 1 ½ ton trucks, material handling, mining and logging operations, flat bed trailers, air freight pullers, off the road tractors, and aboard ships and boats. The 1200WC Series may be ordered galvanized.



**UP TO 12,000 LBS.
CAPACITY**

Bloom Hydraulic Cable Winches – Standard Features

- | | |
|----------------------|--|
| GEAR CASE | - Made of high strength cast iron. Completely sealed for oil enclosed operation and to keep dirt out. |
| WORM SHAFT | - One piece alloy steel hardened and ground for extra durability. |
| WORM GEAR | - High tensile aluminum-nickel alloy bronze. Optimum lead and pressure angles transmit maximum power to the drum. |
| GEAR RATIO | - 20:1 standard, 27:1 and 40:1 optional ratios provide optimum efficiency in power and speed. |
| BEARINGS | - Worm gear and worm shaft run on tapered roller bearings. Outer end housing has a sealed ball bearing. |
| DRUM SHAFT | - 1-1/2" diameter heat -treated alloy steel minimum tensile strength 150,000 psi. |
| CABLE DRUM | - Tough all steel construction resists breakage or warping. |
| CLUTCH OPTION | - 1200C Series winches comes equipped with heat-treated dog type clutch to provide free-spooling of the winch drum. Positive lock-in and lock-out. |
| BRAKE OPTION | - Hydraulic Fail-Safe Brakes disengages when a load is lifted and automatically engages when power is removed or the load is lowered. |



BLOOM

Manufacturing Inc.

Winch Division

"Custom Engineered Solutions"

**Lifting
Pulling
Hoisting**

Toll Free Number: 1-800-394-1139

www.bloommfg.com

1443 220th Street, Independence, Iowa 50644 • FAX: 319-827-1140 • PHONE: 319-827-1139

1200WC Series

Model Selection from Performance Data



"Quality Since 1910"

MODEL EXAMPLE: **12W-3.2M-L8-C-RH-20**

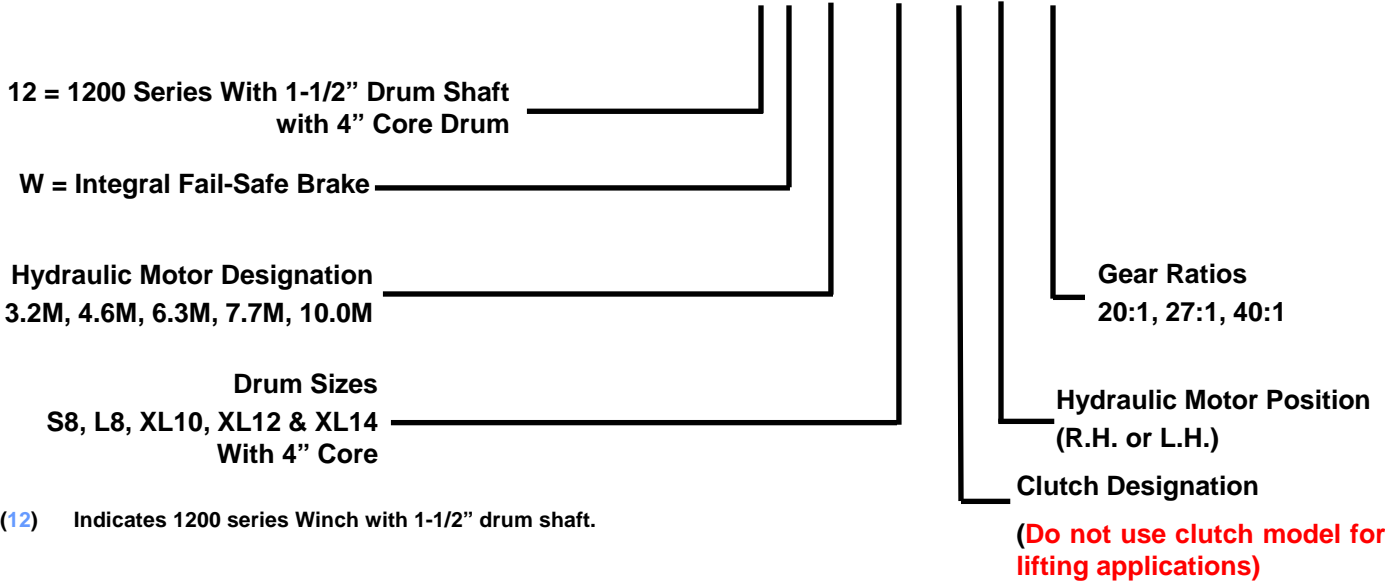

DRUM CAPACITY

CABLE DIAMETER (IN.)	1/4	5/16	3/8	7/16	1/2
DRUM "S8" CAPACITY (FT.)	260	160	105	75	55
DRUM "L8" CAPACITY (FT.)	390	240	160	110	80
DRUM "XL10" CAPACITY (FT.)	840	550	340	250	170
DRUM "XL12" CAPACITY (FT.)	1320	840	580	380	280
DRUM "XL14" CAPACITY (FT.)	1900	1180	760	540	410

(RH) Hydraulic motor may be placed on either side of gear case. Specify right hand (RH) or left hand (LH) as viewed looking at gear case cover. Right hand is standard.

(20) Indicates gear ratio. 20:1 is standard. 27:1, and 40:1 are also available.

Series 1200WC



"Quality Since
1910"

Bloom Hydraulic Cable Winches With Oil Cooled Automatic Safety Brake Model Selection from Performance Data

20:1 RATIO (standard)

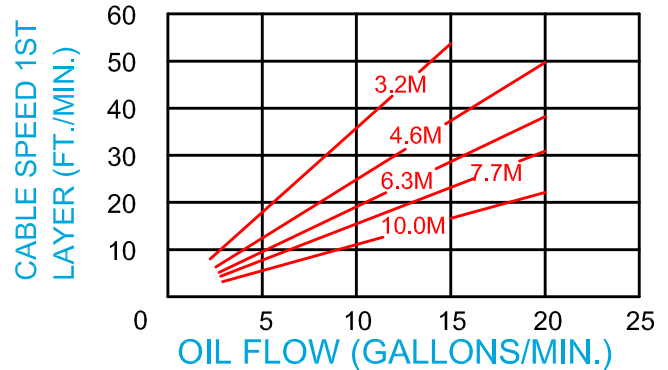
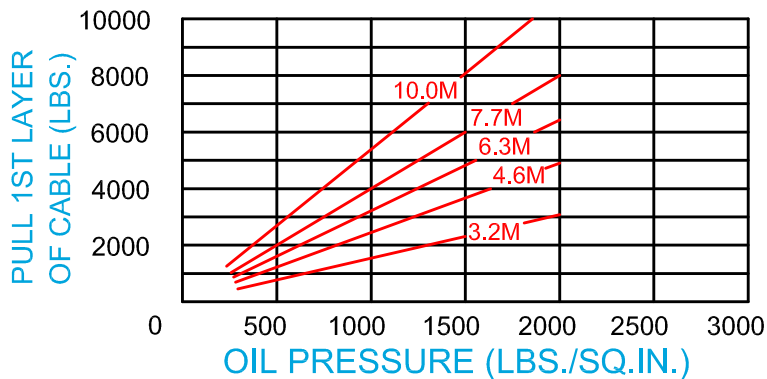

27:1 RATIO (optional)

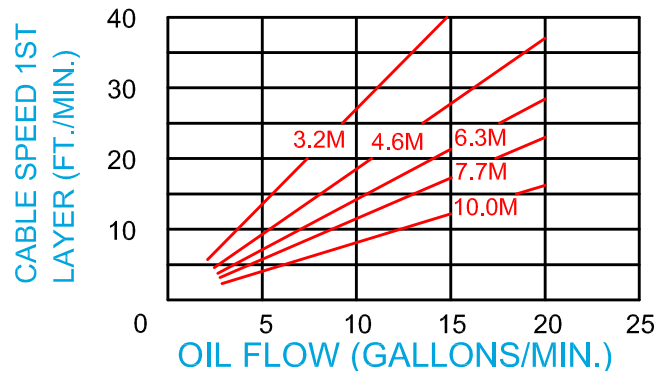
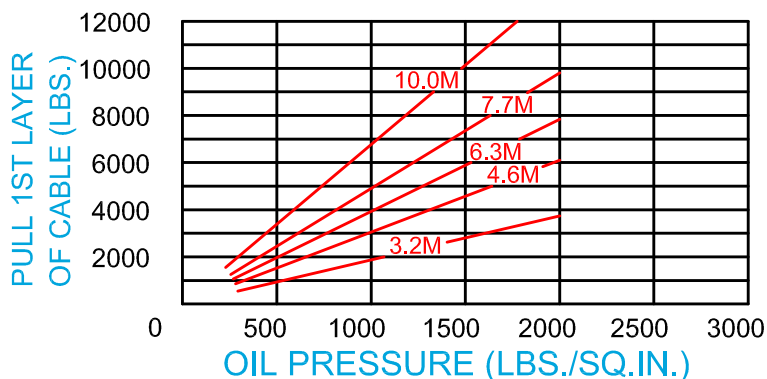

40:1 RATIO (optional)

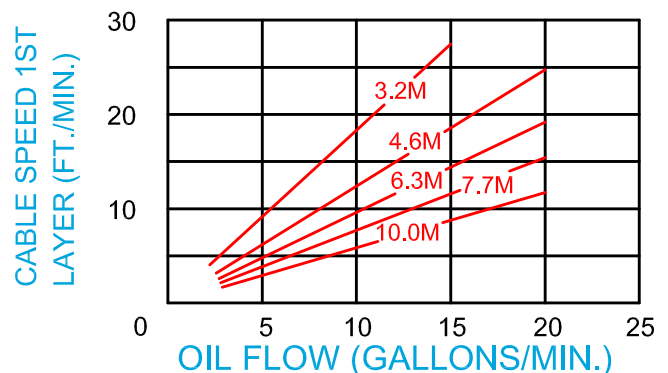
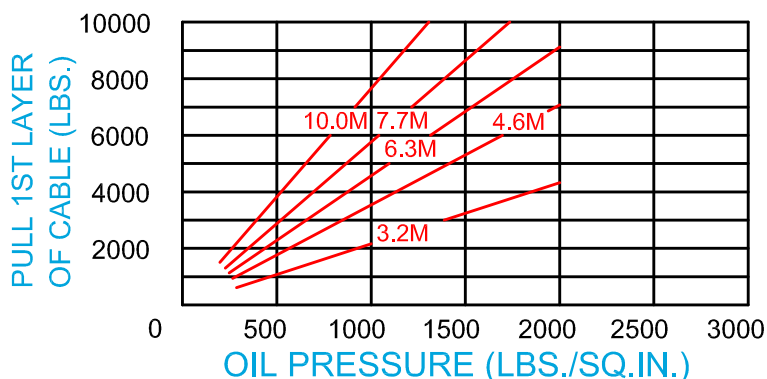

Bloom Manufacturing Inc.

Winch Division
1443 220th Street
Independence, IA 50644

www.bloommfg.com
Email: sales@bloommfg.com engineering@bloommfg.com

800-394-1139 tel
319-827-1139 tel
319-827-1140 fax



Dimensional Drawings

1200W Series With S8 and L8 Drum
Base Mount Model - Clutch Drive

“Quality Since
1910”

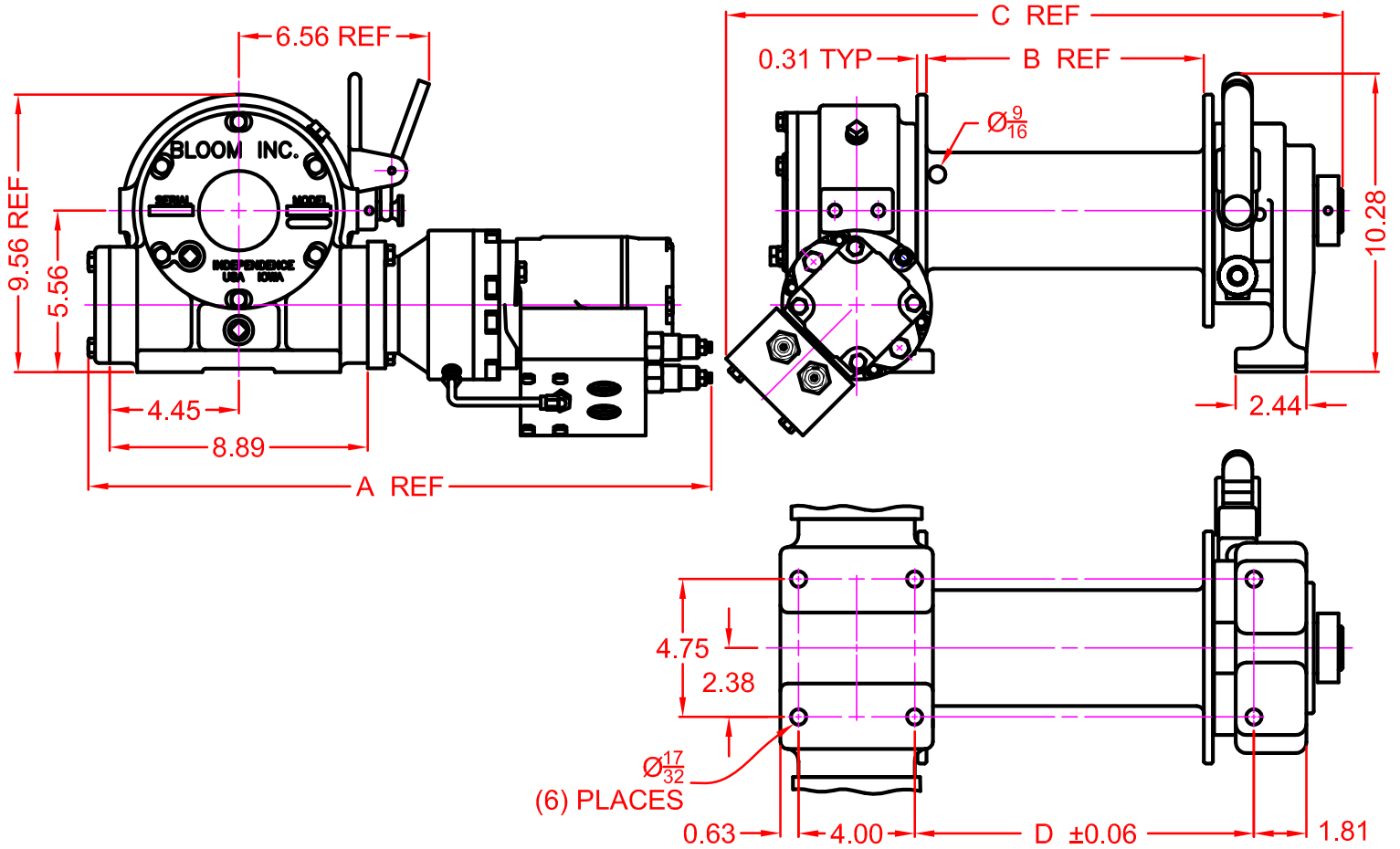

MOTOR DESIGNATION	3.2	4.6	6.3	7.7	10.0
A DIMENSION	19.90	19.90	19.90	19.90	19.90

DRUM DESIGNATION	WINCH DIMENSION		
	B	C	D
S8	6.69	18.25	8.68
L8	9.69	21.25	11.68

Bloom Manufacturing Inc.

Winch Division
1443 220th Street
Independence, IA 50644

www.bloommfg.com
Email: sales@bloommfg.com engineering@bloommfg.com

800-394-1139 tel
319-827-1139 tel
319-827-1140 fax



"Quality Since
1910"

Dimensional Drawings

1200W Series With XL10, XL12 & XL14 Drum
Base Mount Model - Clutch Drive

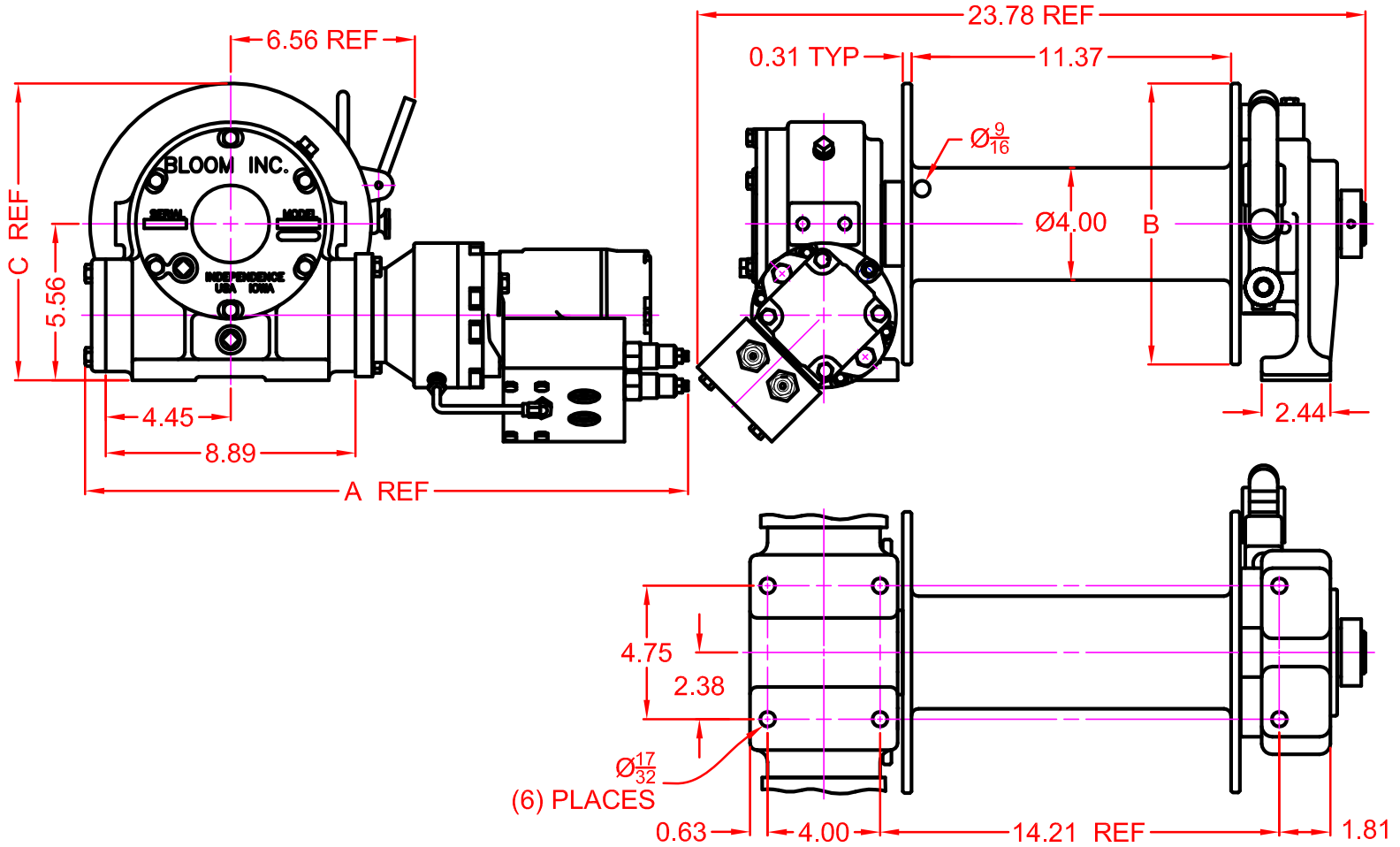

MOTOR DESIGNATION	3.2	4.6	6.3	7.7	10.0
A DIMENSION	19.90	19.90	19.90	19.90	19.90

DRUM DESIGNATION	XL10	XL12	XL14
B DIMENSION	10	12	14
C DIMENSION	10.56	11.56	12.56

Bloom Manufacturing Inc.

Winch Division
1443 220th Street
Independence, IA 50644

www.bloommfg.com
Email: sales@bloommfg.com engineering@bloommfg.com

800-394-1139 tel
319-827-1139 tel
319-827-1140 fax

Correct choice of Directional Control Valves for Bloom Winches

Motor Spool Valve – Work Ports are **open** to tank in neutral position

Use on all winches that use Counter Balance Valves to hold load.

Some winches may use a combination of CB Valve and Hydraulic Brake.

*Winches require ridged mounting plate.

See owner's manual for information about proper mounting plate thickness or call Bloom Sales Engineer at factory.

WARNING!

Goods are not intended for use in the moving or lifting of persons!

The winches described herein are neither designed nor intended for use or application to equipment used in the lifting or moving of persons and it is understood that all such use shall be at the sole risk of the user.

The cable clamps on winches are not designed to hold rated loads. A minimum of 5 wraps of cable must be left on drum barrel to guarantee holding of rated load.

Applications of winch where life would be endangered by any event are not recommended.

